



Mestrado integrado em Medicina Dentária

Faculdade de Medicina da Universidade de Coimbra

**Influence of repeated tightening and loosening of the prosthetic screw in micromovements abutment / implant.**

Tiziano Marinucci

**Orientador:** Professor Doutor Fernando Guerra

**Co-Orientador:** Dr. Salomão José Coelho Silva Rocha

**Coimbra, 2013**

## Summary

<b>Abstract</b> .....	2
<b>1. Introduction</b> .....	3
<b>2. Materials and Methods</b> .....	5
Preparation of the samples .....	5
Loading Test .....	7
Digital Acquisition of Micromovements.....	7
Calibration .....	9
Statistical Analyses.....	10
<b>3. Results</b> .....	11
<b>4. Discussion</b> .....	15
<b>5. Conclusion:</b> .....	18
<b>6. Acknowledgment</b> .....	19
<b>7. Bibliografia:</b> .....	20

## **Influence of repeated tightening and loosening of the prosthetic screw in micromovements abutment / implant.**

Marinucci T., Rocha S., Guerra F.

Department of Dentistry, Faculty of Medicine, University of Coimbra

Av. Bissaya Barreto, Blocos de Celas

3000-375 Coimbra, Portugal

E-Mail: tiziano-88@hotmail.it

### **Abstract**

**Background:** Micromovements in the implant-abutment connection may influence periimplant bone preservation, especially in the cervical region of the implant. The purpose of this study was to evaluate and quantify these micromovements after repeated cycles of tightening and loosening the prosthetic screw using the method of three dimensional image correlation (DIC 3D). **Materials and Methods:** 10 Mis® Seven internal hexagon 4.2x13 implants were included in an acrylic block with similar elasticity of bone and randomly allocated into 2 groups. Mis® Titanium abutments (Standard cementing post, anti-rotational) were screwed to the implants at 30Ncm torque and loaded up to 200N with an universal testing machine (AG-I Shimadzu®) at a 30° angle. Samples were then randomly allocated into two groups. Group I was submitted to one cycle of loosening and retightening of the abutment screw and group II was submitted to 2 consecutive cycles of loosening and tightening of the abutment screw. Each sample was loaded again and the micromovements captured with Vic-3D (Correlated Solutions, Inc), in three axis U, V, W, corresponding to the movements in the mesio-distal, vertical and antero-posterior directions, statistical analysis was performed using SPSS 20.0, considering independent samples t-test for group comparison and paired samples t-test for intra-group comparison. Mixed ANOVA was used to determine the interaction of screw loosening and tightening cycles and load on the micromovements of the abutments. **Results:** No statistically significant differences were found between groups regarding the three directions, under any load. Also, no statistically significant differences were found between micromovements before and after the screwing cycles for each group. However, absolute displacement was higher in Group II under 100N load than in Group I after the protocol with a statistically significant difference of -0.168 (95% CI, -0.321 to -0.016),  $t(8)=-2.55$ ,  $p=0.03$ . **Conclusion:** The implant/abutment connection according to the protocol performed, demonstrated good resistance and a precise fit between these interfaces, therefore, in case of unscrewing is not justified changing the screw.

## 1. Introduction:

In the last ten years there has been a great evolution in research and technology of dental implantology, especially regarding the surfaces of implants and implant / abutment interfaces.(1)

The improvement of the structure and function of the connection between implant, abutment and respective screw, increased the stability over time of the peri-implant hard and soft tissues and has been considered one of most important factors regarding biological and mechanical complications. The former are mainly identifiable with perimplantitis, while the second are related to the prosthetic components of an implant-supported rehabilitation. These have frequently been reported as loosening and fracture of fixation screws, loss of retention due to fracture of the abutment, fracture of the metal or ceramic structure of the crown and, less often, implant fracture. Different studies have shown that among the mechanical complications, screw loosening is a problem closely linked to the stability of the junction of the screw that does not depend only on the tightening torque, but also on the fit of both the abutment and the screw in the internal taper of the implant.(1-6)

Functionally, the prosthetic screw does the union of the implant to the different prosthetic components, and their stability is directly proportional to the stability of the prosthesis. As outlined in the literature there is a set of clinical factors that can lead to loosening of the screws with a consequent loss of tension and preload.(4-7)

Increase in load requests of the implant-abutment interface, results in unscrewing and subsequent opening of the fixture-abutment interface which is expressed as rotational movements of the implant-prosthetic interface.(2, 8, 9)

The loads (such as masticatory forces, dynamics transversal, transverse displacements) and temperature may cause functional loss of axial preload, due to compression of the screw head against the abutment, which causes plastic alterations to the screw and subsequent reduction of friction between the threads of the screw and the internal taper of the implant generating torque forces that cause the micromovements. The geometric design of the abutment and screw is also responsible of the accuracy of the components, affecting the micromovements of the assembly. Also the quality of peri-implant bone (density) seems to have some impact on the strains and deformations that occur in the abutment. For instance the maxillary bone undergoes greater deformation in relation to the mandibular, which might in some case lead to greater stress in connection bone / implant and the possible consequence of instability of the screw.(2, 4, 6-9)

The screw is undoubtedly the part of the implant that has a greater risk of fracture due to the reduced diameter in relation to the implant and the abutment. Nowadays, most implant systems take this as a safety factor, due to the higher value in economic terms, time and professional act, being the abutment or the implant much more problematic and expensive to

Influence of repeated tightening and loosening of the prosthetic screw in micromovements abutment / implant.

replace. In addition this has been purposely designed so that there's no forces transferred to the bone, what leads to absence of risk of retrograde periimplantitis.(2, 4-7)



Several parameters such as friction, geometric properties of the screw, the taper angle, and the elastic properties of the materials on the mechanics of the system, precision of fit of the mating components and rotational characteristics of the screws have been identified as responsible for the maintenance of screw tension. To prevent it, e.g. alert by control screw torque and control angle between implant and abutment, the torque applied to the screw, named preload, has an extreme importance. (2, 4, 7-9)

The aim of this study was to evaluate and quantify the micro-movements of abutments after repeated tightening and loosening of prosthetic screws through the method of dimensional 3D Digital Image Correlation (DIC 3D), using implants with hexagonal internal connection and respective abutments (Mis® Standard cementing post, Anti-Rotational).

## 2. Materials and Methods:

The aim of this study was to quantify the micro-movements of single crown abutments for single with two different screwing strategies, using Digital Image Correlation (DIC 3D). The characteristics of the implants, abutments and prosthetic screws used are summarized in table I. The components devices were manufactured by MIS Implants Technologies GmbH (Israel).

**Table I** – Characteristics of the implants, abutments and prosthetic screws used for the two experimental groups

		Type	Dimensions	Characteristics	Reference	Material
<b>Implant</b>		Seven® Standard plataform	4.2x13	Internal hex.	MF7-13420	Ti-6Al-4V ELI (Grade 23)
<b>Abutment</b>		Standard cementing post	4.75x11	Anti-rotational	MD-MAC10	Titanium
<b>Prosthetic screw</b>		Direct prosthetic screw internal hex	7.6 (length)	-	MD SO220	Titanium

### Preparation of the samples

10 MIS® Seven® Standard implants with a internal hexagon connection and a platform diameter of 4.2 mm and length of 13 mm were embedded in fast acrylic Technovit® 4000 (Heraeus Kulzer, Wehrheim Germany), leaving about 3mm of implant outside the resin surface, using standardized plastic tubes that allowed implant stabilization perpendicular to the ground.

Technovit® 4000 (Heraeus Kulzer, Wehrheim Germany) is a three-component resin, based on modified polyester, available in the form of powder, syrup I and syrup II, mixed at a ratio of 2:2:1 and doesn't present an exothermic polymerization reaction. This acrylic resin is distinguished by low shrinkage during polymerization, perfect margin fit and excellent adhesion properties to metal, which are guarantees of gapless embedding of all metal samples. More, Technovit® 4000 presents elasticity modulus similar to bone. These properties are of particular importance when working

Influence of repeated tightening and loosening of the prosthetic screw in micromovements abutment / implant.

with samples that require good edge definitions and that simulate situations of osseointegrated implants.(10)



**Fig.I:** Technovit 4000– Heraeus Kulzer, Wehrheim Germany.

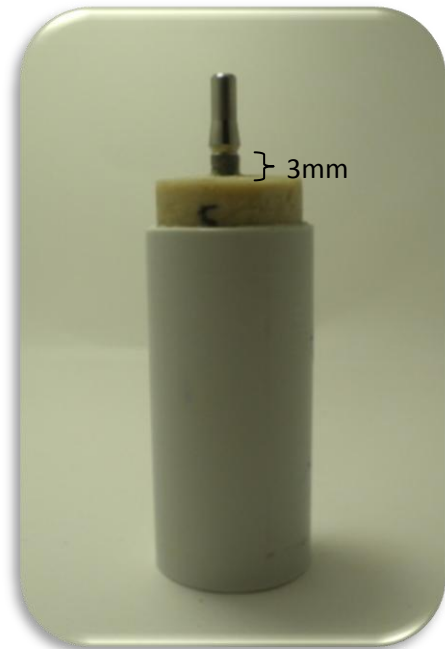

**Fig.II:** implants incorporated in the resin, leaving about 3mm of implant outside the resin surface, with plastic when this was does.

After cure, the samples were randomly allocated into two groups to which two different screw tightening protocols were applied.(10)

**Group 1:** 5 Mis® titanium internal hexagon connection Standard Cementing post, with an anti-rotational flat face, with 11 mm of height, were tightened to the implants according to the instructions of the manufacturer with a torque of 30 Ncm. The samples were submitted to a sequence of loads of 50, 100, 150, 200N and then the prosthetic screw was loosened with the torque wrench. The screw was then tightened again with 30Ncm torque and submitted to the sequence of loads, making a total of **2** tightening and unscrewing cycles.

**Group 2:** 5 Mis® titanium internal hexagon connection Standard Cementing post, with an anti-rotational flat face, with 11 mm of height were tightened to the implants according to the instructions of the manufacturer with a torque of 30 Ncm. The samples were submitted to a sequence of loads of 50, 100, 150, 200N and then the prosthetic screw was loosened with the torque wrench. The screw was then tightened again with 30Ncm torque and then unscrewed and tightened again with the torque wrench to 30Ncm, making a total of **3** tightening and unscrewing cycles.

## Loading Test

Using a platform we were allowed to load the abutments at an angle of  $30^\circ$  with the vertical axis. This value was obtained according to the study of Morneburg et al. with a force of up to 200 N. For this purpose, a universal test-machine (AG-I Shimadzu®, Riverwood Drive, USA) was used, with an established velocity of 0,5mm/min until the maximum force was reached.(11, 12)

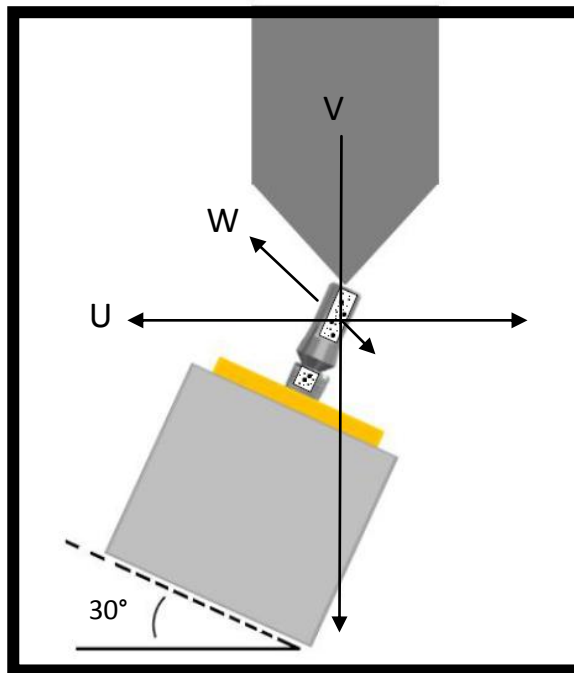

**Fig.4:** Scheme of de loading test, represented U, V and W axis, at angles of  $30^\circ$  relative to the implant axis.

## Digital Acquisition of Micromovements

In recent years optical full-field measuring techniques are increasingly being used in research and industry as development and design tools for improved characterization of materials and components, due to rapid new developments of high resolution digital cameras and computer technology.(13)

Image Correlation techniques are useful tools for deformation analysis, using two cameras to accomplish a three-dimensional evaluation. As a full-field image analysis method, it is based on grey value digital images that allow the determination of the contour and surface displacements of an object under load in three dimensions. 3D DIC is an extremely useful tool for experimental mechanics.(13-15)





**Fig.III:** DIC 3D camera setup

Using this advanced methodology, an object is observed by from different angles by two cameras and the position of each object point is focused on a specific pixel in the camera plane. After the calibration of the two cameras positions relatively to each other, knowing the magnifications of the lenses and all imaging parameters, the absolute 3-dimensional coordinates of any surface point in space can be calculated. This is done for every point of the object surface, and the 3D surface contour of the object can be determined in all areas observed by both cameras. Looking from different positions at an object, two image sensors offer enough information to perceive the object as three dimensional, comparable to human vision.(13-15)

Deformation measurements with very high resolution are possible even under the presence of large deformation amplitudes and macroscopic rigid body movements, since the system determines the absolute position and displacement of the object in space.(13, 14)

Each object point is focused on a specific pixel in the image plane of the respective camera, using a stereoscopic camera setup. A stochastic intensity pattern was used on the object surface and the position of each surface point in the two images can be identified by applying a correlation algorithm. Thus, a matching accuracy of the original and the transformed facet of better than 0.01 pixel can be achieved. The stochastic pattern used was applied with a colored spray paint and cut in squares so that it could be pasted: one in the abutment and another in the implant. (13-15)

The position of each object point in three dimensions can be calculated knowing the imaging parameters for each camera (intrinsic parameters: principle point and distortion parameters, focal length) and the orientations of the two cameras with respect to each other (extrinsic parameters: rotation matrix and translation vector). (13)

The interface of the implant-abutment connection was examined and the micromovement measurements were performed by the optical method of 3D digital image correlation (DIC) with two high speed photographic cameras (Point Grey GRAS-20S4M-C, 1624x1224 pixels) which can capture images at a maximum frame rate of 19 fps (frames per second) and the video correlation system Vic-3D 2010 (Correlated Solutions®, Columbia, USA).(13, 14)

The DIC 3D method is an optical measurement technique that can determine the three dimensional contour of most micromovements of big or small object's surfaces, obtaining displacement fields without contact and with high resolution (MJ, 2011). This system uses the digital image of two high speed photographic cameras (Point Grey GRAS-20S4M-C, 1624x1224 pixels) and the video correlation software Vic-3D 2010, to track the surface displacement field of an object. (13, 14)

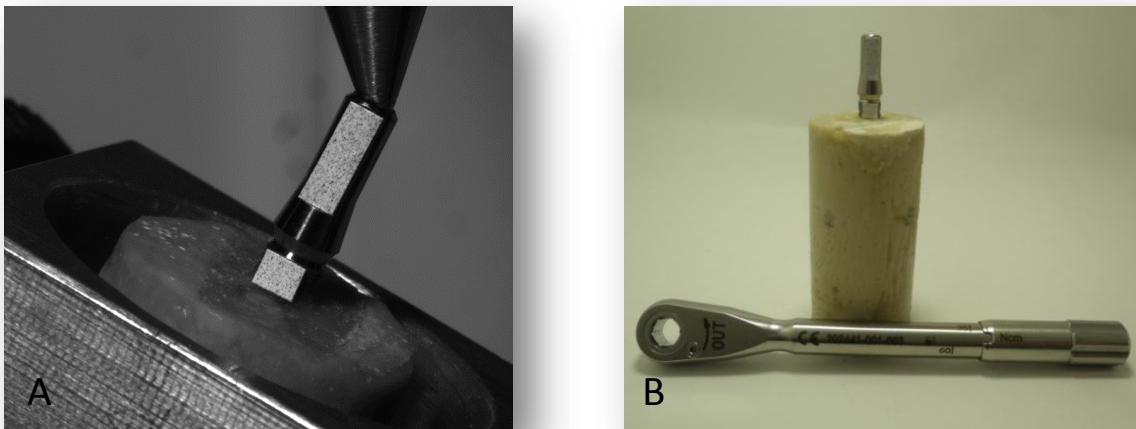

**Fig.5:** A- A sample being tested in the test-machine (AG-I Shimadzu) using a pointed tip; B- Embedded implant and fixation of the abutment tightening the screw with torque 30 Ncm.

### Calibration

The calibration process is described as the process of determining the intrinsic projection parameters (focal length of the lenses, principle point of the lenses, radial distortions of the lenses, tangential distortions of the lenses) and extrinsic (translation vector, rotation matrix) imaging parameter. The calibration of the cameras has essential influence on the performance of the complete system. Therefore, in order to make a useful measuring instrument, the calibration procedure must be integrated into the complete system design and must be as simple as possible.(13, 14)

To calibrate, the system displays, in real-time, the tracking of target markers and automatically acquires a sequence of images of the target positioned at different angles.(14)

In this first step, we used a test plate that is manually moved in front of the camera. The camera records only different positions of the test plate, which give sufficient data for the complete this procedure. Image acquisition takes just some seconds and after some more seconds the calibration of the intrinsic parameters is finished, the calibration of the cameras was made and a score is given to each calibration.(13, 14)

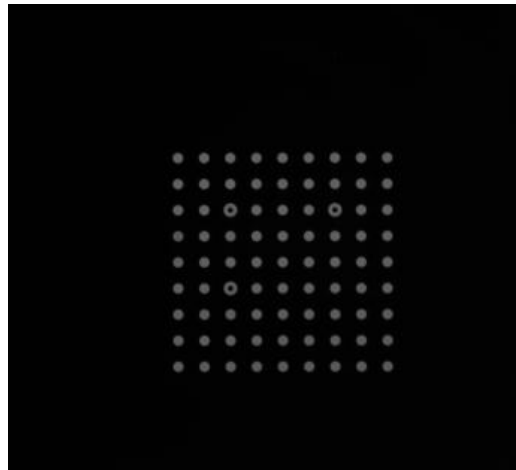

**Fig.6:** Image of the plate

The quality of the measurement is directly related to the accuracy of the projection parameters.(14)

The three-dimensional coordinates for each object point are calculated leading to a 3-dimensional contour of the object, using the projection parameters of the system. Along with the loading steps, each camera follows the changes of the grey value pattern and the surface displacements of the object are calculated. A series of about 400 images corresponding to a time sequence of 0,08 seconds was evaluated.(13, 14)

Each time the cameras are used there is an error of projection for each measurement and a limit is defined that indicates that a new calibration is needed.(14)

### **Statistical Analyses**

For each abutment, maximum values of micromovements obtained under loads of 50, 100, 150, 200N were registered. Statistical analysis was performed using IBM SPSS Statistics Version 20.0. Mean, standard deviation and confidence intervals for the mean were calculated per group. Independent samples t-test was performed to compare groups, paired samples t-test was used to assess the differences between initial and final conditions within each group and a Mixed ANOVA procedure was used to determine the effect of load and group on the variation of the micromovements. Significance level was set at  $\alpha=0,05$ .

### 3. Results

The maximum values of micromovements exposed to maximum forces of 50, 100, 150, 200N, at angles of 30° relative to the implant axis, in the initial conditions (single abutment screw joint closing to 30Ncm torque) and the final conditions (one or two cycles of screw loosening and retightening to 30N torque, according to the testing group) were detected in all samples. For each loading condition, three types of movements in different directions were captured by Vic 3D system. According to recorded movements there are different values for:

**U:** refers to the lateral movement, from left to right, when negative values it refers to the movement of the object to the left;

**V:** refers to the occluso-cervical movement, when values are negative it translates the deepening of the object occluso movement;

**W:** refers to the antero-posterior movement, when the values are negative it translates the posterior movement of the object.

Rigid body motion was removed considering the implant as the fixed surface and figure 7 shows representative images obtained with Vic 3D. Maximum values were registered considering the highest absolute value within each direction. The mean values of maximum displacement per direction and standard deviation are summarized in table II (appendix). Additionally, an independent-samples t-test was conducted to determine whether the mean difference between the groups was statistically significantly different to zero. Mean difference and test values are reported in table II. No statistically significant differences were found for group comparison under the initial conditions in any direction. After the loosening and tightening protocol, still no differences were found between groups regarding the three directions, under any load. However, there was a trend to higher values of micromovements in the V axis under loads of 50N and 100N for Group 2, with a mean difference of 0.033 (95% CI, -0.004 to 0.070),  $t(8) = 2.075$ ,  $p = 0.072$  and 0.073 (95% CI, -0.012 to 0.158),  $t(8) = 1.969$ ,  $p = 0.084$ , respectively.

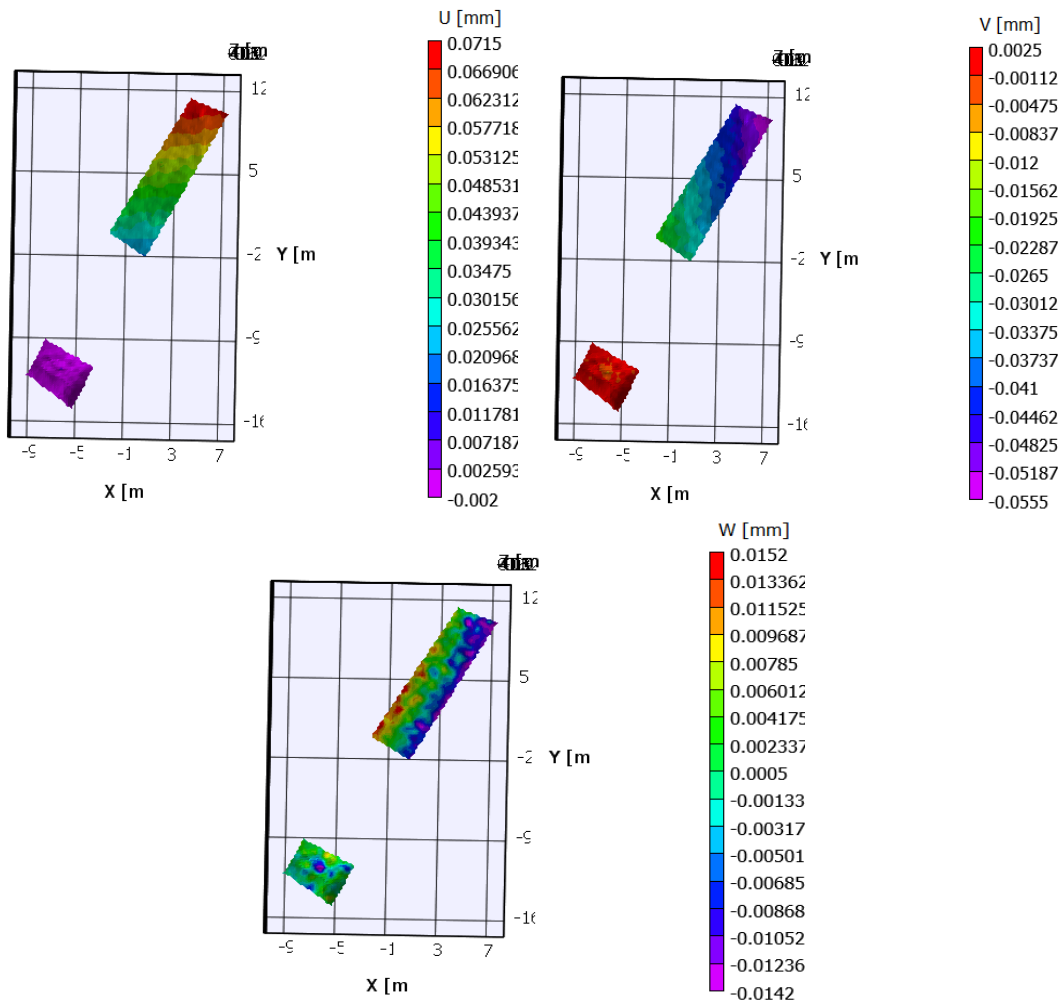

**Figure 7:** Graphical representation of the abutment and implant surfaces studied, obtained via 3D image correlation. This graphics show the movements (U,V,W) of the abutment comparing with the implant (inferior left corner).

A paired-samples t-test was used to elucidate whether there was a statistically significant mean difference between the micromovements of each sample under the initial and final conditions, per group. One outlier was detected in each group and was removed for the analysis. All variables respected Normality, as assessed by Shapiro-Wilk test. No statistically significant differences were found in any pair.

The absolute values of micromovements in each of the three directions U, V, Z were used to determine the absolute displacement of each sample, as follows:

$$\text{Absolute displacement} = |U| + |V| + |W|$$

The variable *absolute displacement* was calculated for each load applied over the samples and for both moments, before and after the screw loosening and tightening protocol. The mean values of maximum absolute displacement and standard deviation are summarized in table II. An

independent-samples t-test was run to determine if there were differences in absolute displacement between Group 1 and Group 2.

There were no outliers in the data and values were normally distributed for each level of load applied, as assessed by Shapiro-Wilks test ( $p > .05$ ). Only absolute displacements under in the final conditions under 150N and 200N showed no homogeneity of variances, as assessed by Levene's Test for Equality of Variances and were interpreted accordingly. Absolute displacement was higher for Group II after the protocol under 100N load ( $0.326 \pm 0.139$ ) than for Group I ( $0.157 \pm 0.051$ ), a statistically significant difference of 0.168 (95% CI, 0.016 to 0.321),  $t(8) = -2.55$ ,  $p = 0.03$ .

**Table II:** Independent samples t-test for absolute displacement comparison between Groups 1 and 2, under the four tested loads in the initial and final conditions. Values are in millimeters and represent mean  $\pm$  Standard Deviation.

	Absolute displacement							
	50N		100N		150N		200N	
	Initial	Final	Initial	Final	Initial	Final	Initial	Final
<b>Group 1 (I)</b>	0.119 $\pm$ 0.093	0.093 $\pm$ 0.050	0.220 $\pm$ 0.167	0.157 $\pm$ 0.051	0.217 $\pm$ 0.076	0.207 $\pm$ 0.074	0.351 $\pm$ 0.203	0.2535 $\pm$ 0.064
<b>Group 2 (J)</b>	0.183 $\pm$ 0.099	0.143 $\pm$ 0.053	0.273 $\pm$ 0.123	0.326 $\pm$ 0.139	0.329 $\pm$ 0.150	0.333 $\pm$ 0.175	0.374 $\pm$ 0.157	0.368 $\pm$ 0.172
<b>Mean difference (I-J)</b>	-0.064	-0.050	-0.053	-0.168	-0.112	-0.126	-0.023	-0.114
<b>t-test</b>	T(8)=-1.06, p=0.32	T(8)=-1.54, p=0.16	T(8)=-0.56, p=0.59	T(8)=-2.55, p=0.03	T(8)=-1.49, p=0.18	T(5.389)=-1.49, p=0.19	T(8)=-0.20, p=0.85	T(5.087)=-1.40, p=0.22

A mixed ANOVA was applied to understand if there was an interaction between the loads and the protocol applied over each sample on the dependent variable *absolute displacement*. Comparison was performed using the values obtained after the application of the protocol. Mixed ANOVA assumptions were fulfilled and there was homogeneity of covariances, as assessed by Box's test of equality of covariance matrices ( $p = 0.30$ ). Due to sphericity violation, Greenhouse-Geisser corrections were considered for interaction determination. No statistically significant interaction between the protocol and loads applied on absolute displacement,  $F(1.36, 10.90) = 1.33$ ,  $p = 0.29$ , partial  $\eta^2 = 0.142$ .

The main effect of Group showed no statistically significant difference in absolute displacement between intervention groups  $F(1, 8) = 3.78$ ,  $p = 0.088$ , partial  $\eta^2 = 0.321$ . Nevertheless, there was statistically significant difference in absolute displacement at the different load points,  $F(1.36, 10.89) = 15.23$ ,  $p = 0.001$ , partial  $\eta^2 = 0.656$ , when considering the main effect of loads applied.

Variations of marginal absolute displacement in function of loads applied are displayed in graphic I for both groups.

**Graphic II:** Absolute displacement Estimated Marginal Means graphic.

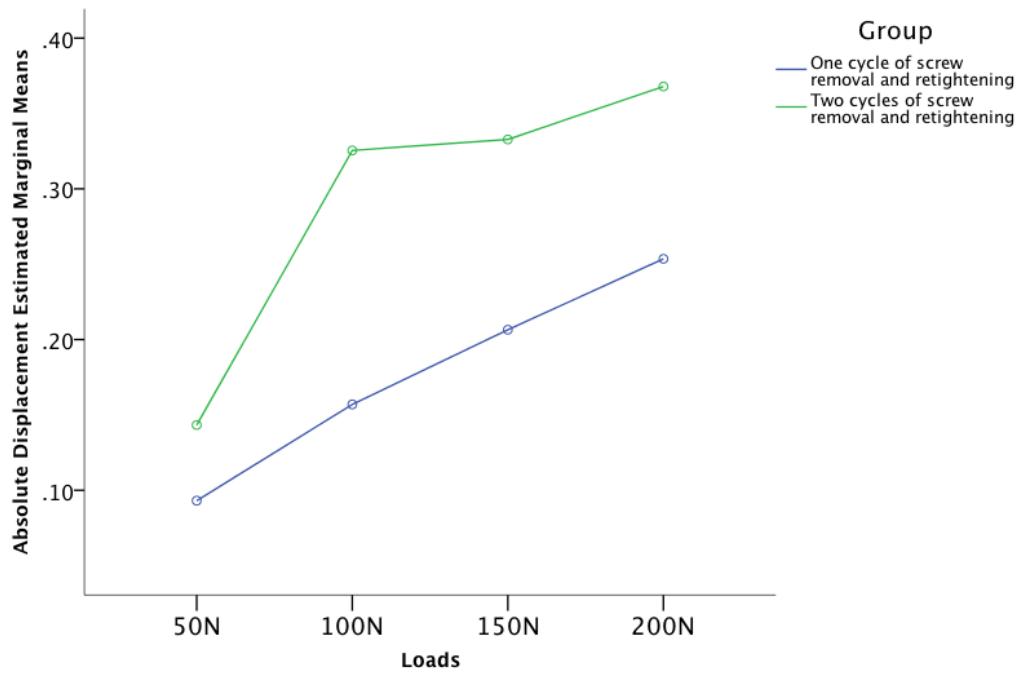

## 4. Discussion

In general, the reliability and the stability of an implant–abutment connection mechanism is an essential prerequisite for long-term success of dental implants. The fixation of the abutment to the implant through a threaded coupling system is one of the major factors contributing for this stability. Thus, screw complications encountered with the screw-type implant–abutment connection mechanism, such as loosening or fracture are responsible for the majority of failures associated to implant rehabilitations.(16, 17)

Several parameters such as friction, geometric properties of the screw, the taper angle, and the elastic properties of the materials on the mechanics of the system have been identified as responsible for the maintenance of screw tension. More, screw pretension has been closely associated to tightening torque, meaning that screw loosening could occur due to inadequate preload(18). The precision of fit of the mating components and rotational characteristics of the screws also increases the risk of screw loosening and/or fracture and is associated to bacterial leakage through the implant-abutment interface which imperils the biological stability of the implant-abutment complex on the long-term.(18, 19)

Screw loosening is a recognized problem in implants dentistry, as it is necessary to remove the overlaying restoration to access the screw to be retightened or replaced. The restorations may be damaged or destroyed in this process particularly cement-retained ones.(17)

When a taper integrated screwed-in type abutment is screwed into the implant, a tensile preload develops in the screw and a resisting force along the main axis of the abutment develops in the tapered part. This resisting force and the screw preload are equal in magnitude. Spontaneous loosening occurs when the prosthetic screws or abutments determine compression in the implant connection, leading to a mild strain of the abutment. This tension exerts an effect in all the connection elements, leaving them in compression and promoting a spring effect.(16, 20)

After the first tightening to the adequate load using a torque wrench occurs mild burnishing and scuffing of the abutment screw thread surfaces, which leads to some misfit of the prosthetic screw within the implant internal thread and friction reduction. Then the external forces progressively erode the preload of the screw because of screw vibration, wear of the mating surfaces, and settling (embedment relaxation).(6)

Long-term loading of abutments that have lost preload magnifies fatigue of the screws and increases the micro-movements of the abutment, eventually resulting in unscrewing of the rehabilitation which requires retightening. Also, necessary clinical procedures for restoration fabrication require serial insertion into an implant and the removal of several screw-retained components before definitive restoration placement. Periodic maintenance often requires additional loosening and tightening of the screw joint. Each time a component is placed, the surface irregularities of the internal implant threads or on the screws may be altered, thereby modifying future frictional resistance to tightening and loosening. Limiting the number of screw joint closing and opening cycles in clinical and laboratory procedures before final screw joint closure during



abutment or restoration insertion may minimize screw loosening.(8, 21)

Repeated tightening and loosening of uncoated abutment retaining screws has been shown to result in a progressive decay in removal torques. By assuming that reverse torque is a measure of the remaining preload, the *in vitro* studies dedicated to the fatigue of prosthetic screws also conjecture that screw loosening increases the micromovements of the abutment. Thus, so far, no direct measurement of the micro-movements of abutments submitted to cycles of tightening and loosening has been presented in the literature.(6, 19, 22)

The method of digital image correlation used in our study makes use of an optical measuring device for true full-field, non-contact and three-dimensional measurement of shape, displacements and strains on components and structures made from almost any material(23). The main objective of this study was the determination of the micromovements induced in an internal hex. abutment under increasing 30° loads after two or three cycles of screw tightening and loosening.(23)

Despite no statistically significant differences were found between the group of two cycles and the group of three cycles regarding the micromovements in each of the axis (U, V, W), there was a trend for differences in the V axis, corresponding to the vertical displacement under 50 and 100N. More, the forces applied showed greater influence on the micromovements of the abutment but there were statistically significant differences of 0.168 (95% CI, 0.016 to 0.321),  $t(8)=-2.55$ ,  $p=0.03$  between groups for 100N loads. This probably means that screws that have had more than two cycles of loosening and retightening are prone to suffer plastic deformation with 50N loads, which is presented at 100N loads as greater micromovements. Our *in vitro* study used no restoration over the abutment and presented very specific assembly conditions making more difficult to transpose the results to a normal clinical situation nevertheless, we believe that this may represent what happens in clinical situations of high occlusal loads or even parafunctions. At higher levels of loads most likely occur deformations of the implant-abutment setting not exclusively related to the prosthetic screw, explaining why no differences were found between the two groups.

Micromovements measurement with digital image correlation allows for visualization and quantification of strains but only on the surface of a testing model, which could be a limitation of this study, once the measurements obtained with Vic 3D are not direct deformations of the prosthetic screw. Another limitation of the study lies on the motion of the complete set under loads. The resilience of the acrylic cylinder prevents the absolute statics of the set in the universal testing machine requiring rigid body motion to be removed, considering that the implant surface as the fixed point.

The system presents a smart calibration tool with feedback of the calibration quality and capable of estimating the uncertainties of the resulting calibration parameters. This, in addition to the determination of the image correlation algorithm uncertainties of the evaluated displacements and strains (projection error), could relay some errors. Notwithstanding that, care was taken to ensure that the error associated to the projection and calibration of the images obtained by the paired cameras rejected the null hypothesis “the projection error is too high and could impair measurements” at a statistical significance level of 0.05.

Finally, the small number of samples per group could limit the value of the clinical implications addressed from the results obtained, suggesting that after three cycles of screw joint opening and closing the micromovements of the abutment are higher and probably should be replaced.

Several clinical studies address the need for replacement of the prosthetic screw after loosening. An example of that is a prospective study, 107 single-tooth implant restorations supported by Brånemark implants (Nobel Biocare AB, Goteborg, Sweden) were submitted to control and follow-up of 5 years reported that 26% of the abutment screws were retightened during the first year. Thirteen of those were replaced by a redesigned gold alloy screw, eliminating the problem of screw loosening or fracture. This was attributed to the increased amount of frictional force (increasing preload too) produced between the gold alloy screw and titanium implant component because tensile and yield strengths are higher for the gold alloy than for titanium.(6, 24, 25)

Some studies reinforce the findings of Kharaisat *et al.*, such as the one by Elias *et al.*(26). and others(27), reporting differences in loosening between different materials while other studies(28) find no significant differences in torque removal of screws(29) with different materials. More, others refute the best performance of the gold-alloy screws. Once optimal preload of a prosthetic screw is achieved when it is elongated but not to a point where the yield strength is exceeded, it would be interesting to study screws with different elastic properties, thus different composition.

Geometry of both the connection and the prosthetic screw should also be addressed in future studies as precision of fit and also design of the structural application, and the type of material are important factors that can influence the response of the implant-abutment connection towards the application of dynamic loads.(30, 31)

Our study could also be improved by the introduction of mechanical fatigue cycles, as presented in the studies by Guzaitis *et al* and others previously mentioned(6, 19, 21, 25). This situation would simulate better the mastigatory cycles and induced fatigue. Besides, the two experimental groups should be submitted to more than 3 screw joint opening and closing cycles, providing that in one group the prosthetic screw was replaced at each cycle. This would allow the evaluation of the differences at a longer term and, most important, quantify the micromovements associated to the abutment alone as a consequence of load fatigue.

Finally, considering that is possible to evaluate on the same samples both the micro-movements and the reverse torque, it would be most interesting to establish a statistical relation between the two variables in future studies.

There is an ongoing need for controlled clinical studies to evaluate the changes in the design of implant components. While in vitro testing may suggest improvements in performance, these should be validated in a clinical environment. More studies are indeed necessary, with a larger group of samples, in order to assess the existence of micromovements.

## 5. Conclusion:

Within the limitations of this in vitro study the following conclusions are:

1. Due to the small number of samples, the study could not have statistically significant results. After the second and third screw tightening prosthesis was observed an increase of micromotion.
2. Absolute displacement was higher for the group presenting two cycles of screw loosening and tightening after the protocol under 100N load than the group presenting only one cycle, a statistically significant difference of -0.168.
3. Nowadays remains a subject of discussion and study, expecting to be able to reach a better outcome for better control and minimization of unscrewing, as well as the micromotion.

## 6. Acknowledgment

To Professor Fernando Guerra for friendship, assistance, support and incentive of this work, as my academic path. To Dr. Salomao Rocha for support and incentive of this research likewise. To Dr. Ana Lúcia Messias for huge support, sympathy, time spent and assistance in statistical analysis. To Dr. Nuno Calha for dedication, availability and encouragement in the concretion of the tests. To Dr. Rui Isidro for all the help given. To Mis® and Klockner® for all the material provided to the study. To my family for all de support, encouragement and sacrifice that done during this 5 years, possibiliting the most adventure to my life, that enriched to professional, cultural and personal level, for this work include. In the end, not to important less, my friends for encouragement, incentive and loyalty that given to me during execution of the job.

## 7. Bibliografia:

1. Di Girolamo M, Mampieri G, Arullani C, Baggi L. Analisi al microscopio ottico di due sistemi implantari megagen con connessione conica. *Quintessenza Internazionale*. 2011;3:61-7.
2. Bedini R, Ioppolo P, Pecci R, Rizzo F, Di Carlo F, Quaranta M. Studio in vitro sulla connessione di sistemi implantari dentali. *RAPPORTI ISTISAN*. 2007;7.
3. Dias RP, Padovan LEM, Hamata MM. Conexões implante-abutment. *Salusvita, Bauru*. 2009;28(3):277-88.
4. Bacchi A, Paludo L, Ferraz Mesquita M, Schuh C, Federizzi L, Oro Spazzin A. Loosening torque of prosthetic screws in metal-ceramic or metal-acrylic resin implant-supported dentures with different misfit levels. *Journal of biomechanics*. 2013;46(7):1358-62. Epub 2013/03/13.
5. Saliba FM, Cardoso M, Torres MF, Teixeira AC, Lourenço EJV, Telles DdM. A rationale method for evaluating unscrewing torque values of prosthetic screws in dental implants. *Journal of Applied Oral Science*. 2011;19(1):63-7.
6. Khraisat A, Hashimoto A, Nomura S, Miyakawa O. Effect of lateral cyclic loading on abutment screw loosening of an external hexagon implant system. *The Journal of prosthetic dentistry*. 2004;91(4):326-34. Epub 2004/04/30.
7. Tavares RRdJ, Xible AA, Bonachela WC, de Araújo CdR. Torque produzido por quatro torquímetros diferentes utilizados em próteses sobre implantes. *Estudo comparativo. Brazilian Dental Science*. 2010;6(1).
8. Bickford JH. *An Introduction to the Design and Behavior of Bolted Joints*: MARCEL DEKKER Incorporated; 1995.
9. Dittmer MP, Dittmer S, Borchers L, Kohorst P, Stiesch M. Influence of the interface design on the yield force of the implant–abutment complex before and after cyclic mechanical loading. *Journal of prosthodontic research*. 2012;56(1):19-24.
10. Heraeus Kulzer MCG. Thecnovit 4000. 2013 [2013jul15]; Available from: [http://heraeus-kulzertechnik.de/en/maerkte\\_1/metallographie/produktbereiche/verbrauchsmaterialien\\_ei\\_nbetten\\_1/technovit\\_4000.aspx](http://heraeus-kulzertechnik.de/en/maerkte_1/metallographie/produktbereiche/verbrauchsmaterialien_ei_nbetten_1/technovit_4000.aspx).
11. Zippich H, Weigl P, Lauer H, Lange B. Micro-movements at the implant-abutment interface: measurements, causes and consequences. *Astra Tech BioManagement Complex™ 7 Surgical techniques 25 Clinical evidence I Restorative solutions 35 II Function 47*. 2012;14(4):18.
12. Morneburg TR, Proschel PA. In vivo forces on implants influenced by occlusal scheme and food consistency. *The International journal of prosthodontics*. 2003;16(5):481-6. Epub 2003/12/04.
13. Siebert T, Crompton MJ. Application of high speed digital image correlation for vibration mode shape analysis. *Application of Imaging Techniques to Mechanics of Materials and Structures, Volume 4*: Springer; 2013. p. 291-8.
14. University TOS. Three-Dimensional Digital Image Correlation. [2013jul15]; Available from: <http://www.mecheng.osu.edu/lab/dmm/node/39>
15. HERBST C. SK. Q400 Application Note - T-Q-400-Basics-3DCORR-002a-EN. 2006.16. Bozkaya D, Muftu S. Mechanics of the taper integrated screwed-in (TIS) abutments used in dental implants. *Journal of biomechanics*. 2005;38(1):87-97. Epub 2004/11/03.
17. Sailer I, Philipp A, Zembic A, Pjetursson BE, Hammerle CH, Zwahlen M. A systematic review of the performance of ceramic and metal implant abutments supporting fixed implant reconstructions. *Clinical oral implants research*. 2009;20 Suppl 4:4-31. Epub 2009/08/12.
18. Schwarz MS. Mechanical complications of dental implants. *Clinical oral implants research*. 2000;11 Suppl 1:156-8. Epub 2001/02/13.

19. Assuncao WG, Barao VA, Delben JA, Gomes EA, Garcia IR, Jr. Effect of unilateral misfit on preload of retention screws of implant-supported prostheses submitted to mechanical cycling. *Journal of prosthodontic research*. 2011;55(1):12-8. Epub 2010/07/16.
20. Bedini R. Studio in vitro sulla connessione di sistemi implantari dentali: Istituto Superiore di Sanità; 2007.
21. Guzaitis KL, Knoernschild KL, Viana MA. Effect of repeated screw joint closing and opening cycles on implant prosthetic screw reverse torque and implant and screw thread morphology. *The Journal of prosthetic dentistry*. 2011;106(3):159-69. Epub 2011/09/06.
22. Vallee MC, Conrad HJ, Basu S, Seong WJ. Accuracy of friction-style and spring-style mechanical torque limiting devices for dental implants. *The Journal of prosthetic dentistry*. 2008;100(2):86-92. Epub 2008/08/02.
23. Clelland NL, Yilmaz B, Seidt JD. Three-dimensional image correlation analyses for strains generated by cement and screw-retained implant prostheses. *Clinical implant dentistry and related research*. 2013;15(2):271-82. Epub 2011/12/17.
24. Henry PJ, Laney WR, Jemt T, Harris D, Krogh PH, Polizzi G, et al. Osseointegrated implants for single-tooth replacement: a prospective 5-year multicenter study. *The International journal of oral & maxillofacial implants*. 1996;11(4):450-5. Epub 1996/07/01.
25. Khraisat A, Abu-Hammad O, Dar-Odeh N, Al-Kayed AM. Abutment screw loosening and bending resistance of external hexagon implant system after lateral cyclic loading. *Clinical implant dentistry and related research*. 2004;6(3):157-64. Epub 2005/02/25.
26. Elias C, Figueira D, Rios P. Influence of the coating material on the loosening of dental implant abutment screw joints. *Materials Science and Engineering: C*. 2006;26(8):1361-6.
27. Stuker RA, Teixeira ER, Beck JC, da Costa NP. Preload and torque removal evaluation of three different abutment screws for single standing implant restorations. *Journal of applied oral science : revista FOB*. 2008;16(1):55-8. Epub 2008/12/18.
28. Dziedzic DSM, Nhata J, Jamcoski VH, Dziedzic M, Dziedzic DSM. Assessment of preload in carbon coated prosthetic screws. *RSBO*.9.
29. Martin WC, Woody RD, Miller BH, Miller AW. Implant abutment screw rotations and preloads for four different screw materials and surfaces. *The Journal of prosthetic dentistry*. 2001;86(1):24-32.
30. Kitagawa T, Tanimoto Y, Odaki M, Nemoto K, Aida M. Influence of implant/abutment joint designs on abutment screw loosening in a dental implant system. *Journal of Biomedical Materials Research Part B: Applied Biomaterials*. 2005;75(2):457-63.
31. Ricciardi Coppedê A, De Mattos MdGC, Rodrigues RCS, Ribeiro RF. Effect of repeated torque/mechanical loading cycles on two different abutment types in implants with internal tapered connections: an in vitro study. *Clinical oral implants research*. 2009;20(6):624-32.

Influence of repeated tightening and loosening of the prosthetic screw in micromovements abutment / implant.

**Table II:** The mean values of maximum absolute displacement and standard deviation are summarized here.

			Group 1	Group 2	Mean difference	Independent samples t-test
50	u	i	0,032 ± 0,021	0,052 ± 0,066	-0,019	T=8, P=0,541
		f	0,066 ± 0,108	0,032 ± 0,06	-0,029	T=8, P=0,368
	v	i	0,061 ± 0,070	-0,057 ± 0,022	-0,004	T=8, P=0,911
		f	-0,014 ± 0,024	-0,047 ± 0,026	0,033	T=8, P=0,72
	w	i	0,022 ± 0,029	0,046 ± 0,075	-0,024	T=8, P=0,524
		f	0,004 ± 0,038	0,027 ± 0,054	0,013	T=8, P=0,677
100	u	i	0,070 ± 0,028	0,100 ± 0,073	-0,03	T=8, P=0,421
		f	0,038 ± 0,041	0,072 ± 0,185	-0,033	T=8, P=0,704
	v	i	-0,128 ± 0,158	-0,093 ± 0,034	-0,036	T=8, P=0,636
		f	-0,028 ± 0,050	-0,101 ± 0,066	0,073	T=8, P=0,84
	w	i	-0,0004 ± 0,026	0,601 ± 0,083	-0,061	T=8, P=0,158
		f	0,059 ± 0,030	0,049 ± 0,058	0,01	T=8, P=0,740
150	u	i	0,100 ± 0,037	0,132 ± 0,069	-0,032	T=8, P=0,391
		f	0,073 ± 0,041	0,144 ± 0,12	-0,071	T=4,907, P=0,266
	v	i	-0,078 ± 0,029	-0,118 ± 0,037	0,04	T=8, P=0,93
		f	-0,070 ± 0,036	-0,122 ± 0,074	0,052	T=8, P=0,197
	w	i	0,011 ± 0,046	0,065 ± 0,099	-0,054	T=8, P=0,296
		f	0,056 ± 0,047	0,034 ± 0,076	0,022	T=8, P=0,594
200	u	i	0,114 ± 0,050	0,153 ± 0,063	-0,039	T=8, P=0,313
		f	0,097 ± 0,039	0,161 ± 0,116	-0,064	T=4,895, P=0,298
	v	i	0,035 ± 0,298	-0,136 ± 0,045	0,171	T=8, P=0,241
		f	-0,088 ± 0,035	-0,135 ± 0,076	0,047	T=8, P=0,245
	w	i	0,086 ± 0,055	0,066 ± 0,108	-0,057	T=8, P=0,324
		f	0,052 ± 0,055	0,054 ± 0,072	-0,002	T=8, P=0,968