



ELSEVIER



Available online at www.sciencedirect.com

ScienceDirect

Procedia - Social and Behavioral Sciences 165 (2015) 260 – 266

Procedia
Social and Behavioral Sciences

CPSYC 2014

Confirmatory Factor Analysis of the Resilience Scale short form in a Portuguese Adolescent Sample

Anáisa Oliveira^a, Ana Paula Matos^b, Maria do Rosário Pinheiro^{c*} & Sara Oliveira^d

^{a,d} Master Graduated, Faculty of Psychology and Educational Sciences, Research Centre of the Cognitive and Behavioural Studies and Intervention, University of Coimbra, Rua Colégio Novo, 3000-115 Coimbra, Portugal

^b Associate Professor, Faculty of Psychology and Educational Sciences, Research Centre of the Cognitive and Behavioural Studies and Intervention, University of Coimbra, Rua Colégio Novo, 3000-115 Coimbra, Portugal

^c Assistant Professor, Faculty of Psychology and Educational Sciences, Research Centre of the Cognitive and Behavioural Studies and Intervention, University of Coimbra, Rua Colégio Novo, 3000-115 Coimbra, Portugal

Abstract

The Resilience Scale (Wagnild & Young, 1993) was developed to assess one's resilience levels. The purpose of the present study is to corroborate the unifactorial structure of the Resilience Scale short version for adolescents (Pinheiro & Matos, 2013) proposed by Wagnild (2009), to explore its reliability and to analyze the association between resilience and depressive symptoms in a Portuguese sample. A Confirmatory Factor Analysis (CFA) was performed in a sample of 308 adolescents, female (n= 167) and male (n=141) with ages ranged between 12 and 17 years (M= 13.77; SD= 1.142). The CFA that was conducted led to the construction of a 12 item scale and replicated the one factor solution. The Cronbach's alpha that was obtained revealed to be good (.87). Results showed that resilience was negatively related with depression and is predictive of depressive symptomatology. However, the percentage of explained variance was low. The original one-dimensional structure of the RS short form was confirmed. The results also support that resilience seems to be a protective factor concerning depressive symptoms. Adolescents who obtained higher resilience scores showed lower degrees of depressive symptomatology. These findings can be important for the development of interventions that aim to prevent and treat depression and other psychopathological problems in the adolescent population.

© 2015 The Authors. Published by Elsevier Ltd. This is an open access article under the CC BY-NC-ND license (<http://creativecommons.org/licenses/by-nc-nd/3.0/>).

Peer-review under responsibility of the Organizing Committee of CPSYC 2014.

Keywords: Factorial Structure; Resilience Scale short form; Adolescence; Depressive Symptomatology

* Corresponding author. Tel.: +351 965 854 032; fax: +351 239 851450.

E-mail address: pinheiro@fpce.uc.pt.

1. Introduction

Over the past decades, studies concerning adolescence and normative development, as well as research about adolescent psychopathology, have significantly increased in the scientific literature (Cicchetti & Rogosh, 2002). Adolescence is a crucial transition from childhood dependence to adult autonomy and it is characterized by several and intense transformations, with the adolescent being confronted with multiples changes (Bénony, 2005). It is also described as a period of intense emotional change, physical transformation, psychological maturation, and social values acquisition (Souza et al., 2008). Teenagers face many challenges and stressful situations associated with educational commitment, social behavior, sexual development, familial conflicts, economical problems, and substance abuse (Salazar-Pousada, Arroyo, Hidalgo, Pérez-López, & Chedraui, 2010).

In the last decade, the interest in protective factors and particularly in the resilience construct has substantially increased. This increment has been motivated by the possibility of identifying protective factors and mechanisms to prevent the development of psychiatric disorders, such as depression (Hjmedal, Aune, Reinfjell, Stiles, & Friborg, 2007).

Concerning childhood and adolescent depression, researchers have defined resilience as the absence of a clinical diagnosis of a depressive disorder or low levels of depressive and internalizing symptomatology (Silk et al., 2007).

Hjmedal et al. (2011), in a study with high school adolescents, suggested that resilience is significantly related to symptoms of internalizing psychiatric disorders and that higher resilience scores predicted lower levels of depression. Furthermore, resilience characteristics seemed to protect against symptoms of depression (Skrove, Romundstad, & Indredavik, 2013).

Resilience has been defined as a positive characteristic that enhances individual adaptation and moderates the negative effects of stress (Wagnild & Young, 1993). It connotes inner strength, competence, optimism, flexibility and the ability to cope positively and bounce back when faced with adversity and challenge (Wagnild, 2009; Wagnild & Collins, 2009). Resilient individuals demonstrate courage and adaptability in the wake of life's misfortunes and manifest adaptive behaviors in the areas of social functioning, morale and somatic health (Wagnild & Young, 1990, 1993).

The Resilience Scale short form is based on the Resilience Scale (RS) and was developed to reduce the participant burden and to increment response (Wagnild, 2009). The first study with the short form was conducted five years after the initial large sample psychometric study with the original scale (Wagnild & Young, 1993).

Notwithstanding the fact that investigations with the RS short form are still scarce, a literature review allowed us to find some studies that assessed the psychometric properties of this instrument, namely in Japan (Nishi, Uehara, Kondo, & Matsuoka, 2010), Nigeria (Abiola & Udofia, 2011), Brazil (Damásio, Borsa, & Da Silva, 2011), Finland (Losoi et al., 2013), and Portugal (Pinheiro & Matos, 2013). All the studies yielded high reliability coefficients, ranging between .81 and .93, and adequate construct validity.

Depression disorders are a group of diseases with a high prevalence and are increasing in the general population (Bahls, 2002a). Additionally, depressive mood, symptoms, and depressive disorders are relatively common during adolescence (Hankin & Abramson, 2002; Kovacs, 2006). In a review of epidemiological studies about depressive disorders in adolescents, a prevalence range of 3.3 to 12.4% was encountered (Bahls, 2002b). This psychopathology can be defined as a cluster of specific symptoms and associated impairment (Thapar, Collishaw, Pine, & Thapar, 2012), and can be manifested through a series of symptoms, including loss of interest in activities normally performed, low self-esteem, social isolation, fatigue, crying, sleep and eating disorders, self-defeating impulses, irritability, difficulties to interact effectively with peers and family, behavior problems, cognitive alterations and decreased academic performance (Masip, Amador-Campos, Gómez-Benito, & Gándara, 2010).

Depression during childhood and adolescence is also considered to be a significant public health concern (Horowitz & Garber, 2006). Several reasons support this concern, including an increase in antidepressant prescriptions for teenagers and a rise in adolescent suicide (Costello, Erkanli, & Angold, 2006). Further, depression is related to poor health behaviors and social challenges, increased risk of suicide, anxiety, conduct disorders (Saluja et al., 2004), substance abuse (Kubik, Lytle, Birnbaum, Murray, & Perry, 2003) and risk behaviors (Brooks, Harris, Trahls, & Woods, 2002).

In the existing literature, the concept of resilience has rarely been applied to the study of depression (Dowrick, Kokanovic, Hegarty, Griffiths, & Gunn, 2008).

2. Purpose of the Study

The aim of this study is to corroborate the unifactorial structure of the Resilience Scale short version for adolescents (Pinheiro & Matos, 2013) proposed by Wagnild (2009), to explore internal consistency and to assess the predictive power of resilience concerning depressive symptomatology in a Portuguese adolescent sample.

3. Research Methods

3.1. Participants

The sample of this study included 308 adolescents that attended both private and public schools in Portugal. 167 participants (53.9%) were female and 141 (45.5%) were male, with ages between 12 and 17 years ($M= 13.77$; $SD= 1.142$). Girls ($M=13.74$; $SD= 1.108$) and boys ($M= 13.82$; $SD= 1.016$) did not differ significantly regarding age ($t=-.867$; $p=.386$). They presented a mean of 7.79 ($SD= 1.1486$) years of education. These participants took part of a wider research project entitled “Prevention of depression in Portuguese adolescents: study of the efficacy of an intervention with adolescents and parents”^{*}.

3.2. Instruments

In the present study the following instruments were administered:

Resilience Scale Short Version (RS-14, Wagnild & Young, 2009; RS-13, Portuguese version by Pinheiro & Matos). The RS short version is a shorter version of the Resilience Scale (RS) and was developed to identify the level of individual resilience. This measure consists in 14 items of the RS long form (items 2, 6, 7, 8, 9, 10, 13, 14, 15, 16, 17, 18, 21 and 23), rated on a 7 point Likert scale. RS14 total scores range from 14 to 98. Scores greater than 90 indicate high resilience levels, scores from 65 to 81 indicate moderately low to moderate resilience, and scores of 64 and below indicate low resilience levels. The principal components factor analysis (direct oblimin rotation) obtained a one-factor solution accounting for 53% of common variance. An internal consistency reliability of .93 (coefficient alpha) was attained. The present study used the Portuguese version (Pinheiro & Matos, 2013), that comprises 13 items (2, 6, 7, 8, 9, 10, 14, 15, 16, 17, 18, 21, 23), one less than the original scale (item 13 was excluded). Regarding the factorial structure, the analysis revealed an unidimensional structure accounting for 53.23% of the total variance. Good reliability was also found ($\alpha=.93$) (Pinheiro & Matos, 2013).

Children's Depression Inventory (CDI, Kovacs, 1985, 1992, 2003; Portuguese version by Marujo, 1994). This measure assesses depressive symptoms in children and adolescents, from 7 to 17 years of age. It consists of 27 items with three answers options, with a score ranging between 0 (no problem) and 2 (severe problem). The total score varies between 0 and 54 points. In the original study five factors were found in this measure: negative mood, interpersonal problems, ineffectiveness, anhedonia, and negative self-esteem. In the Portuguese version a one-factor structure was obtained (Marujo, 1994).

3.3. Statistical Analysis

A Confirmatory Factor Analysis (CFA) was conducted. In order to evaluate the best goodness-of-fit for the original model of the RS short form, the following criteria were considered: $GFI >.90$, $AGFI >.90$, $CFI >.95$, $TLI >.90$ and $RMSEA < .06$ (Kline, 2005; Marôco, 2010). The factorial validity of the items was analyzed by

^{*} The present study was integrated in a research project entitled Prevention of Depression in Portuguese adolescents: efficacy study of an intervention with adolescents and parents, funded by Fundação para a Ciência e a Tecnologia.

standardized factor weight ($\lambda=0.5$) and by individual reliability ($r^2 \geq 0.25$). Discriminant validity was assessed through a chi-square differences test. The assumption of normality was evaluated by the coefficients of skewness (*sk*) and kurtosis (*ku*). Kline (2005) suggests that the skew and kurtosis indices should not be higher than an absolute value of 3 and 10, respectively.

The Cronbach's alpha coefficient was calculated to determine the reliability of the RS short form.

A linear regression analysis was used to test the association between resilience and depressive symptomatology.

All data analysis were conducted using the statistical software package AMOS (Analysis of Moments Structures), version 20 for Windows (SPSS Inc., Chicago, IL.).

4. Findings

In the present study the absolute values of skewness and kurtosis did not indicate violation of the normality assumption. So as to attain the best goodness-of-fit for the RS short form three CFA's were performed. According to Marôco (2010), the analysis of the criterion of Mahalanobis square distance ($MD^2 = p1$ and $p2 < 0.001$) indicated the presence of 13 severe outliers that where subsequently removed.

The results indicated that the goodness-of-fit for the first model was poor (the data can be observed in Table 1- Model 1). Factorial validity and individual reliability of the items were analyzed. All the items, except item 9 ($\lambda = .45$), presented an adequate factor weight. A similar result was obtained regarding individual reliability. Item 9 showed a low reliability value ($r^2 = .20$). Additionally, the MD (modification indices) analysis revealed that the higher LM (Lagrange multipliers) occurred between the covariance of item 9 and 12 ($LM > 11$, $p < .001$). Item 9 (“I can usually find something to laugh about”) was consequently excluded.

A second analysis was carried out. This model revealed a more satisfactory goodness-of-fit (the data can be observed in Table 1- Model 2). Nevertheless, the fit was still weak. All the items showed an acceptable factor weight ($\lambda > 0.5$) and individual reliability ($r^2 > .25$). However, according to the analysis of the modification indices, $LM > 11$ still existed. The higher LM was noted for the covariance between item 4 (“I am friends with myself”) and item 10 (“My belief in myself gets me through hard times”). The items showed similarities relating content, so a covariance between error terms associated with items 4 and 10 was added.

A third and last analysis was performed. This model revealed the best goodness-of-fit (the data can be observed in Table 1- Model 3).

The analysis of the differences between the Chi-Square of models 1 [χ^2 (65)= 233.766] versus model 2 [χ^2 (54)= 179.165] obtained significant results [$\Delta\chi^2$ (11)= 54.601; $p > .001$]. Model 2 displayed lower values of AIC (Akaike Information Criterion), BCC (Browne-Cudeck Criterion) and MECVI (Modified Expected Cross-Validation Index) (227.165; 229.287; .747, respectively) when compared to Model 1 (287.766; 288.250; .939). Subsequently, the analysis of the differences between the Chi-Square of models 2 [χ^2 (54)= 179.165] vs model 3 [χ^2 (53)= 148.297] was equally significant [$\Delta\chi^2$ (1)= 30.868; $p > .001$]. Model 3 demonstrated lower valued of AIC, BCC e MECVI (198.297; 200.508; .653) when compared to model 2 (227.165; 229.287; .747). Model 3 displayed the lowest values for AIC, BCC, and MECVI indices, in comparison to models 1 and 2.

Table 1. Confirmatory Factor Analysis of the Resilience Scale short form and goodness-of-fit indexes

Unifactorial model of the RS short form	χ^2 / df	CFI	GFI	AGFI	TLI	RMSEA
Model 1	3.596***	.87	.89	.85	.84	.09
Model 2	3.318***	.89	.91	.87	.87	.09
Model 3	2.798***	.92	.93	.89	.90	.08

Note: CFI: *Comparative Fit Index*; GFI: *Goodness-of-Fit Index*; AGFI: *Adjusted Goodness-of-Fit*; TLI: *Tucker-Lewis Index*; RMSEA: *Root Mean Square of Approximation*.

* $p < .05$; ** $p < .01$; *** $p < .001$

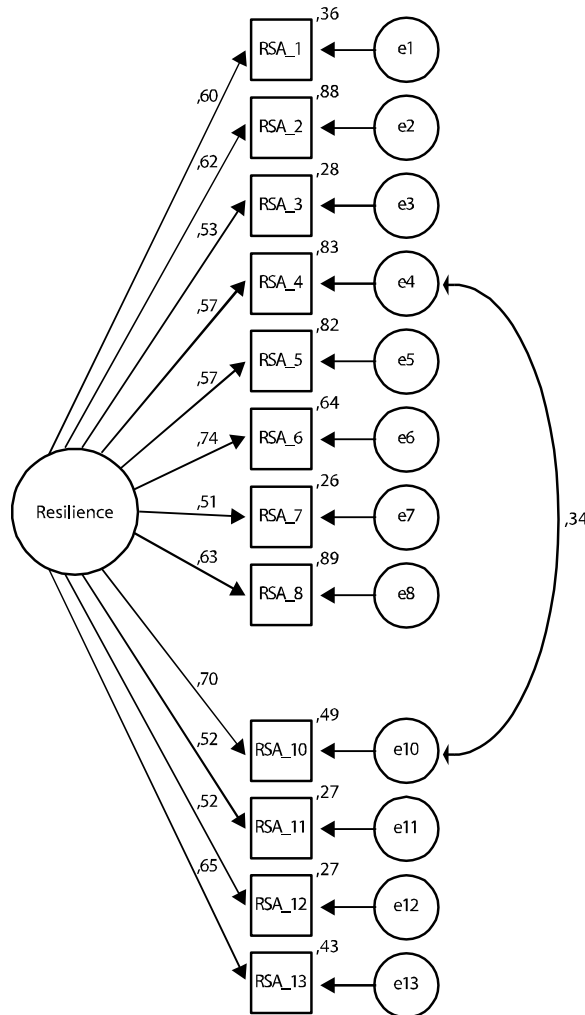

Fig.1- Model 3 for the Resilience Scale short form

So as to assess internal reliability of the 12 items scale, Cronbach’s alpha was calculated. A value of .87 was yielded, indicating that the scale’s reliability is good.

The associations between the variables depressive symptomatology, measured by CDI (n= 188) and resilience, measured by RS short form was previously analyzed. Significant negative and moderate correlations between the scales total scores were found ($r = -.42$; $p < .01$). In order to determine the predictive power of resilience concerning depressive symptomatology, a linear regression analysis was performed. The dependent variable was the CDI total score and the independent variable was the RS short form total score. A statistically significant model between the two measures was encountered [$F(1;187) = 39.07$; $p < .05$] and 18% percentage of explained common variance ($\beta = -.42$; $t = -6.25$; $p < .05$) was attained.

5. Conclusions

The purpose of the present study was to corroborate the unifactorial structure of the Resilience Scale short form for adolescents (Pinheiro & Matos, 2013) in a Portuguese adolescent sample.

In order to do so, a Confirmatory Factor Analysis (CFA) was performed. The results revealed the existence of a scale composed of 12 items (items 1, 2, 3, 4, 5, 6, 7, 8, 10, 11, 12 and 13), distributed by a common latent factor that is resilience. The CFA lead to the elimination of one item (item 9 – “I can usually find something to laugh about”).

Note that the exclusion of the item occurred due to the application of a more conservative statistical procedure regarding factorial validity. Every item should present standardized factorial weights superior or equal to .5 and individual reliabilities superior or equal to .25 (Marôco, 2010). Additionally, the assessment of the goodness-of-fit of the model (that was based on the interpretation of the chi-square values, chi-square differences test, and analysis of the goodness-of-fit indexes) showed that the new model that was obtained in this study is better than the original one.

The present findings support the one factor solution for the RS short form in an adolescent sample, replicating the unifactorial structure found by Wagnild (2009) and by the authors of the Portuguese version of the instrument (Pinheiro & Matos, 2013). Others studies carried out with the RS short form equally encountered an unifactorial structure (Damásio et al., 2011; Losoi et al., 2013; Nishi et al., 2010).

Considering the internal reliability of the measure, the RS short form presents a good Cronbach's alpha value ($\alpha = .87$). The result is similar to the one attained by Wagnild (2009) and Pinheiro & Matos (2013). In comparison to other reliability studies, the coefficient found by us is equal to the one obtained by Losoi et al. (2013), close to the value encountered by Nishi et al. (2010), and superior to the coefficient yielded by Damásio et al. (2011) and Abiola & Udofia (2011).

Regarding the association between the RS short form and CDI, a statistically significant one was observed. This finding allows us to infer the predictive power of resilience regarding depressive symptoms. That is, adolescents who scored higher on the resilience measure showed lower levels of depressive symptomatology. Nevertheless, the percentage of variance obtained was relatively low. This result is similar to the one obtained by Hjmedal et al. (2007). The present finding may be important for the development of new treatments in order to prevent depressive episodes in adolescent population.

This is one of the first studies designed to validate the unifactorial structure of the Resilience Scale in an adolescent sample.

This investigation is also a contribution to the study of cross-cultural validation of the RS. To understand resilience several studies have been conducted in different cultures and groups because it is expected that cultural and social contexts can influence resilience.

Despite the importance of the present research, some limitations can be encountered. The sample only included community adolescents. Investigations with larger and more diverse samples should be performed. Samples should, for example, comprise institutionalized adolescents or teenagers with depressed parents.

We underline to pursue further studies about the predictive power of resilience in relation to depressive symptomatology. We performed a cross-sectional study, so we cannot make conclusions about the cause-effect relationship established between the variables. Longitudinal studies are crucial to explore this association.

In conclusion, the Resilience Scale short form revealed to be a reliable instrument for the assessment of resilience levels in teenagers and can possibly be used in several settings, including educational and clinical contexts.

This measure can also be useful to verify the efficacy of intervention programs to prevent and treat depressive symptomatology in adolescents and to promote protective factors. When we study resilience we identify personal and relational protective factors that can guide preventive interventions designed to develop skills and psychosocial resources to cope with adversity and accept self and life (Pinheiro & Matos, 2013).

Acknowledgements

The authors would like to express their gratitude to all the participants of the research project "Prevention of depression in Portuguese adolescents: study of the efficacy of an intervention with adolescents and parents". This work is funded by ERDF - European Regional Development Fund through the COMPETE Programme (operational programme for competitiveness) and by National Funds through the FCT - Fundação para a Ciência e a Tecnologia (Portuguese Foundation for Science and Technology), within project «PTDC/MHC-PCL/4824/2012».

References

- Abiola, T., & Udofia, O. (2011). Psychometric assessment of the Wagnild and Young's resilience scale in Kano, Nigeria. *BMC Research Notes*, 4, Article 509. doi: 10.1186/1756-0500-4-509

- Bahls, S.C. (2002a). Aspetos clínicos da depressão em crianças e adolescentes. *Jornal de Pediatria*, 78(5), 359-366.
- Bahls, S.C. (2002b). Epidemiology of depressive symptoms in adolescents of a public school in Curitiba, Brazil. *Revista Brasileira de Psiquiatria*, 24(2), 63-67.
- Bénony, H. (2005). *L'Examen psychologique et clinique de l'adolescent*. Paris: Editions Nathan-Université.
- Brooks, T.L., Harris, S.K., Thrall, J.S., & Woods, E.R. (2002). Association of adolescent risk behaviors with mental health symptoms in high school students. *Journal of Adolescent Health*, 31, 240-246.
- Cicchetti, D., & Rogosch, F. (2002). A developmental Perspective on Adolescence. *Journal of Consulting and Clinical Psychology*, 70(1), 6-20. doi: 10.1037//0022-006X.70.1.6
- Costello, E., Erkanli, A., & Angold, A. (2006). Is there an epidemic of child or adolescent depression?. *Journal of Child Psychology and Psychiatry*, 47(12), 1263-1271.
- Damáso, B.F., Borsa, J. C., & da Silva, J.P. (2011). 14-Item Resilience Scale (RS-14): Psychometric Properties of the Brazilian Version. *Journal of Nursing Measurement*, 19(3), 131-145. doi: 10.1891/1061-3749.19.3.131
- Dowrick, C., Kokanovic, R., Hegarty, K., Griffiths, F., & Gunn, J. (2008). Resilience and depression: perspectives from primary care. *Health: An Interdisciplinary Journal for the Social Study of Health, Illness, and Medicine*, 12(4), 439-452.
- Hankin, B., & Abramson, L. (2002). Measuring Cognitive Vulnerability Depression in Adolescence: Reliability, Validity, and Gender Differences. *Journal of Clinical Child and Adolescent Psychology*, 31(4), 491-504.
- Hjmdal, O., Aune, T., Reinfjell, T., Stiles, T., & Friborg, O. (2007). Resilience as a Predictor of Depressive Symptoms: A Correlational Study with Young Adolescents. *Clinical Child Psychology and Psychiatry*, 12(1), 91-104.
- Hjmdal, O., Vogel, P., Solem, S., Hagen, K., & Stiles, T. (2011). The Relationship between Resilience and levels of Anxiety, Depression, and Obsessive-Compulsive Symptoms in Adolescents. *Clinical Psychology and Psychotherapy*, 18, 314-321.
- Horowitz, J., & Garber, J. (2006). The Prevention of Depressive Symptoms in Children and Adolescents: A Meta-Analytic Review. *Journal of Consulting and Clinical Psychology*. 74(3), 401-415. doi: 10.1037/0022-006X.74.3.401
- Kovacs, M. (1985). The Children's Depression Inventory (CDI). *Psychopharmacology Bulletin*, 21(4), 995-998.
- Kovacs, M. (1992). *Children's Depression Inventory (CDI) Manual*. Toronto: Multi-Health Systems Inc.
- Kovacs, M. (2003). *Children's Depression Inventory (CDI): Technical Manual Update*. Toronto: Multi-Health Systems Inc.
- Kovacs, M. (2006). New steps for research on child and adolescents depression prevention. *American Journal of Preventive Medicine*, 31, 184-185.
- Kline, R.B. (2005). *Principles and Practice of Structural Equation Modeling* (2nd Ed.) New York: Guilford Press.
- Kubik, M., Lyle, L., Birnbaum, A., Murray, D., & Perry, C. (2003). Prevalence and Correlates of Depressive Symptoms in Young Adolescents. *American Journal of Health Behavior*, 27(5), 546-553.
- Losoi, H., Turunen, S., Wäljas, M., Helminen, M., Öhman, J., Julkunen, J., & Rosti-Otajärvi, E. (2013). Psychometric Properties of the Finnish Version of Resilience Scale and its Short Version. *Psychology, Community, & Health*. 2(1), 1-10. doi: 10.5964/pch.v2i1.40
- Marujo, H.M. (1994). *Síndromas depressivos na infância e na adolescência* (Doctoral Dissertation). Faculdade de Psicologia e de Ciências da Educação, Lisboa.
- Marôco, J. (2010). *Análise de Equações Estruturais: Fundamentos teóricos, software e aplicações*. Lisboa: Report Number.
- Masip, A.F., Amador-Campos, J.A., Gómez-Benito, J., & Gándara, V. (2010). Psychometric Properties of the Children's Depression Inventory in Community and Clinical Sample. *The Spanish Journal of Psychology*, 13(2), 990-999.
- Nishi, D., Uehara, R., Kondo, M., & Matsuoka, Y. (2010). Reliability and validity of the Japanese version of the Resilience Scale and its short version. *BMC Res Notes*, 3, Article 310. doi:10.1186/1756-0500-3-310
- Pinheiro, M. R., & Matos, A. P. (2013). Exploring the construct validity of the two versions of the Resilience Scale in a Portuguese adolescent sample. *The European Journal of Social & Behavioural Sciences*, 2(10), 178-189. Retrieved from: [http://dx.doi.org/10.15405/FutureAcademy/ejsbs\(2301-2218\).2012.2.5](http://dx.doi.org/10.15405/FutureAcademy/ejsbs(2301-2218).2012.2.5)
- Saluja, G., Iachan, R., Scheidt, P., Overpeck M., Sun, W., & Giedd, J. (2004). Prevalence of and Risks Factors for Depressive Symptoms Among Young Adolescents. *Pediatrics & Adolescent Medicine*, 158, 760-765.
- Salazar-Pousada, D., Arroyo, D., Hidalgo, L., Pérez-López, F., & Chedraui, P. (2010). Depressive Symptoms and Resilience among Pregnant Adolescents: A Case-Control Study. *Obstetrics and Gynecology International*, Volume 2010, Article ID 952493, 7 pages. doi: 10.1155/2010/952493
- Silk, J., Vanderbilt-Adriance, E., Shaw, D., Forbes, E., Whalen, D., Ryan, N., & Dahl, R. (2007). Resilience among children and adolescents at risk for depression. Mediation and moderation across social and neurobiological contexts. *Development and Psychopathology*, 19, 841-865.
- Souza, L., Silva, R., Godoy, R., Cruzeiro, A., Faria, A., Pinheiro, R., Horta, B., & da Silva, R. (2008). Sintomatologia depressiva em adolescentes iniciais – estudo de base populacional. *Jornal Brasileiro de Psiquiatria*, 57(4), 261-266.
- Skrove, M., Romundstad, P., & Indredarik, M. (2013). Resilience, lifestyle and symptoms of anxiety and depression in adolescence: the Young HUNT study. *Social and Psychiatry and Psychiatric Epidemiology*, 48, 407-416.
- Thapar, A., Collishaw, S., Pine, D., & Thapar, A. (2012). Depression in adolescence. *Lancet*, 579(17), 1056-1067.
- Wagnild, G.M., & Young, H.M. (1990). Resilience among older women. *Image: The Journal of Nursing Scholarship*, 22(4), 252-255.
- Wagnild, G.M., & Young, H.M. (1993). Development and psychometric evaluation of the Resilience Scale. *Journal of Nursing Measurement*, 1(2), 165-178.
- Wagnild, G.M. (2009). *The Resilience Scale user's guide for the US English version of the Resilience Scale and the 14-Item Resilience Scale (RS-14)*. Worden, MT: The Resilience Center.
- Wagnild, G.M., & Collins, J. (2009). Assessing Resilience. *Journal of Psychosocial Nursing*, 47(12), 28-33.