

# Seminar PCMs4Buildings

PCMs: Thermophysical characterization and  
buildings' applications

Coimbra, 14-15 June, 2018

## BOOK OF EXTENDED ABSTRACTS AND POSTERS

### Organizing Committee

Adélio R. Gaspar  
Ana Ramos  
José J. Costa  
Luísa Durães  
Margarida Gonçalves  
Nelson Soares  
Pedro N. Simões  
Telma Matias



ADAI – Association for the Development of Industrial Aerodynamics (Editor)  
N. Soares (Editorial Coordinator)



The Seminar "*PCMs4Buildings – PCMs: Thermophysical characterization and buildings' applications*" was organized in the framework of Task 6 of the research project PCMs4Buildings – Systems with PCM-filled rectangular cavities for the storage of solar thermal energy for buildings ([www.adai.pt/pcms4buildings](http://www.adai.pt/pcms4buildings)).

The two-days Seminar was aimed to disseminate the first results of the project PCMs4Buildings concerning the main challenges of the thermophysical characterization of phase change materials (PCMs) and the analysis of the thermal behaviour of some PCMs-based applications for buildings.

Several Portuguese research groups with relevant research on PCMs and thermal energy storage (TES) systems were invited to bring their contribution to the discussion. The presence of international key-speakers with relevant experience on the main topics of the Seminar was also extremely valuable for the accomplishment of the event.

The first day and the second day morning were devoted to keynote lectures and talks. The afternoon of the second day was devoted to the Workshop – "*Thermophysical characterization of PCMs*". This Workshop was divided into two main sessions: "*Thermal analysis session*" and "*Hot Disk<sup>®</sup> session*".

The Seminar and the Workshop took place in the Department of Chemical Engineer of the University of Coimbra.

The project PCMs4Buildings is supported by FEDER funds through the COMPETE 2020 - POCI, and by Portuguese funds through FCT in the framework of the project POCI-01-0145-FEDER-016750 | PTDC/EMS-ENE/6079/2014.



# Table of Contents

## Book of extended abstracts

- Systems with PCM-filled rectangular cavities for the storage of solar thermal energy for buildings: the case of the PCMs4Buildings project..... 4
- Pros and cons of different calorimetric methodologies applied to PCM in building applications ..... 7
- Thermophysical characterization of commercial paraffin-based PCMs for low temperature thermal energy storage applications..... 10
- The importance of the thermophysical characterization of microencapsulated PCMs for the numerical analysis of the heat transfer with solid-liquid phase change ..... 13
- Assessment of latent heat storage of PCM-mortars: a case study using a full-scale experimental test ..... 20
- Use of PCMs in polyurethane foam layers: from the individual layer to building solutions ..... 24
- Incorporation of phase change materials (PCM) in ceramics for building applications ..... 29
- New solutions for building envelope: Building Integrated Photovoltaic Systems with integral thermal storage..... 33
- Thermal regulation of photovoltaic modules using thermal energy storage units with PCMs..... 37
- Developments in thermal energy storage, the case of the TESSe2b project..... 41
- Development of PCM thermal energy storage for active cooling of the indoor space .... 44
- Multi-functional ventilated BiPV façade concept coupled with PCM..... 47
- Measuring the thermal conductivity of PCMs - dos and don'ts ..... 51
- Properties of cement mortars with phase change materials (PCM's) ..... 55
- Phase change materials for improving the thermal performance of LSF construction..... 58
- Thermal performance of a window shutter with phase change materials ..... 63
- The SCORES project and the new compact hybrid storage technologies ..... 68
- A degradation model and the associated activation energy of organic phase change materials ..... 71
- Beeswax as phase change material: Chemical modification and mixtures with hydrogenated waste cooking oil and with paraffin ..... 75
  
- Annex: Book of posters ..... 78**

## SYSTEMS WITH PCM-FILLED RECTANGULAR CAVITIES FOR THE STORAGE OF SOLAR THERMAL ENERGY FOR BUILDINGS: THE CASE OF THE PCMS4BUILDINGS PROJECT

N. Soares<sup>1,2\*</sup>, A.G. Lopes<sup>1</sup>, M. Gonçalves<sup>2</sup>, A.R. Gaspar<sup>1</sup>, C. Martins<sup>2</sup>, T. Matias<sup>3</sup>,  
P. Santos<sup>2</sup>, P.N. Simões<sup>3</sup>, L. Durães<sup>3</sup> and J.J. Costa<sup>1</sup>

<sup>1</sup> ADAI, LAETA, Dep. of Mechanical Engineering, University of Coimbra, Coimbra, Portugal

<sup>2</sup> ISISE, Dep. of Civil Engineering, University of Coimbra, Coimbra, Portugal

<sup>3</sup> CIEPQPF, Dep. of Chemical Engineering, University of Coimbra, Portugal

\* Correspondent author: Nelson Soares, nelson.soares@dem.uc.pt

**Keywords:** Phase change materials (PCMs), thermal energy storage (TES), building applications, solar thermal energy.

**Abstract** *This paper provides an overview of the ongoing research project "PCMs4Buildings - Systems with PCM-filled rectangular cavities for the storage of solar thermal energy for buildings". The main goal of this project is to develop a holistic approach for the experimental and numerical evaluation of the thermal behaviour of new thermal energy storage (TES) systems with rectangular cavities filled with phase change materials (PCMs) for building applications. The project also intends to define full-scale prototypes to be numerically and experimentally optimized. "PCMs4Buildings" is a challenging project involving researchers from different scientific backgrounds, namely civil, mechanical and chemical engineering and two institutions: the Association for the Development of Industrial Aerodynamics (ADAI) and the University of Coimbra (UC). It also involves three research units, the Associate Laboratory of Energy, Transports and Aeronautics (LAETA), the Institute for Sustainability and Innovation in Structural Engineering (ISISE) and the Chemical Process Engineering and Forest Products Research Centre (CIEPQPF).*

### 1. FRAMEWORK

PCMs are materials that undergo melting/solidification at a nearly constant temperature. Therefore, they are very suitable for thermal management and TES applications (Figure 1). They also provide a large heat capacity over a limited temperature range (due to the latent heat involved in the solid-liquid phase change processes). Some PCMs have been identified in literature for integration in different TES systems and several ways of containment (in order to avoid liquid leakage) have been studied and optimized [1].

Commercial paraffin waxes to be used as PCMs in TES applications have typically low thermal conductivity which can be problematic regarding the efficiency of these elements. The incorporation of fins of high-conductivity material within rectangular macrocapsules containing PCMs has been one of the techniques used for containment and to improve the heat transfer through the PCM-bulk. These capsules can then be integrated in different TES systems such as PCM-enhanced concrete walls, PCM-bricks, PCM-shutters, PCM-window blinds, PCM-enhanced photovoltaic systems, PCM-enhanced solar panels, etc.

For these reasons, solid-liquid phase change in rectangular cavities is of great interest from the theoretical point of view and for the development of new TES systems.

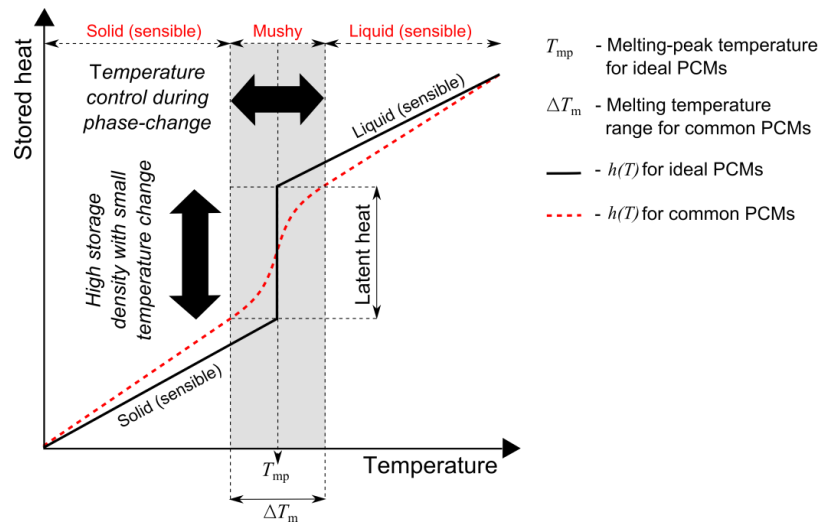

Figure 1. Potential fields of application of PCMs: (i) temperature control and (ii) storage and supply of heat with high storage density in a small quantity of material [2].

The specific goals of the 3-years project "PCMs4Buildings" [3] are: (i) to propose new TES systems for improving the energy performance of existing systems and/or to take advantage of solar thermal energy for reducing cooling and heating energy demand in buildings; (ii) to create an active multidisciplinary lab provided with the skills and equipments necessary to study new passive TES systems incorporating PCM-filled rectangular cavities for building applications; and (iii) to create a dynamic organization scheme to cover all the research steps necessary for the study of new TES systems, from the thermophysical characterization of the materials to the final experimental and numerical evaluation of the thermal performance of some prototypes. The problems to be studied lie in the mainstream areas of (i) the experimental and numerical characterization of the heat transfer through rectangular cavities filled with PCMs; (ii) the characterization of the thermophysical properties of PCMs; (iii) the CFD simulations considering solid-liquid phase-change processes; and, (iv) the experimental evaluation of the overall transient heat transfer through both small- and full-scale, non-homogeneous TES building structures. It is believed that the "PCMs4Buildings" project will give new and relevant contributions to the present knowledge in these research fields. Additionally, the team aims to be better positioned to participate in worldwide inter-laboratory studies and to join a network of research groups that today exchange not only samples to be characterized, but also researchers to potentiate the research carried out. The team will organize several national and international events to foster the dissemination of the results. These events are aimed to bring together researchers from different institutions, students and several companies in order to share experiences and to potentiate future research.

## 2. METHODOLOGY - MAIN TASKS

The research plan is composed by six main tasks (Figure 2): (i) thermophysical characterization of PCMs; (ii) numerical modelling and CFD evaluation; (iii) tests in the small-scale experimental setup; (iv) tests in the Guarded Hot Box apparatus; (v) definition of full-scale prototypes; (vi) technical seminars and workshop. Task 1 refers to the

evaluation of alternative methods for the thermophysical characterization of PCMs. Task 2 involves the numerical modelling of the heat transfer with solid-liquid phase change and the development of a CFD methodology for a detailed parametric analysis of the thermal behaviour of TES systems. Task 3 involves developing an experimental methodology to provide benchmarking data for numerical validation purposes, considering an existing setup designed to measure the transient heat transfer with phase-change through small-scale TES units. Task 4 involves adapting the existing Guarded Hot Box apparatus installed in the Civil Engineering Department of the University of Coimbra to evaluate the thermal performance of full-scale prototypes in a transient mode, and to provide experimental data for validating more complex CFD models. Task 5 involves the design of full-scale prototypes to be numerically and experimentally optimized. Task 6 involves organizing technical seminars and workshops to disclose the results achieved.

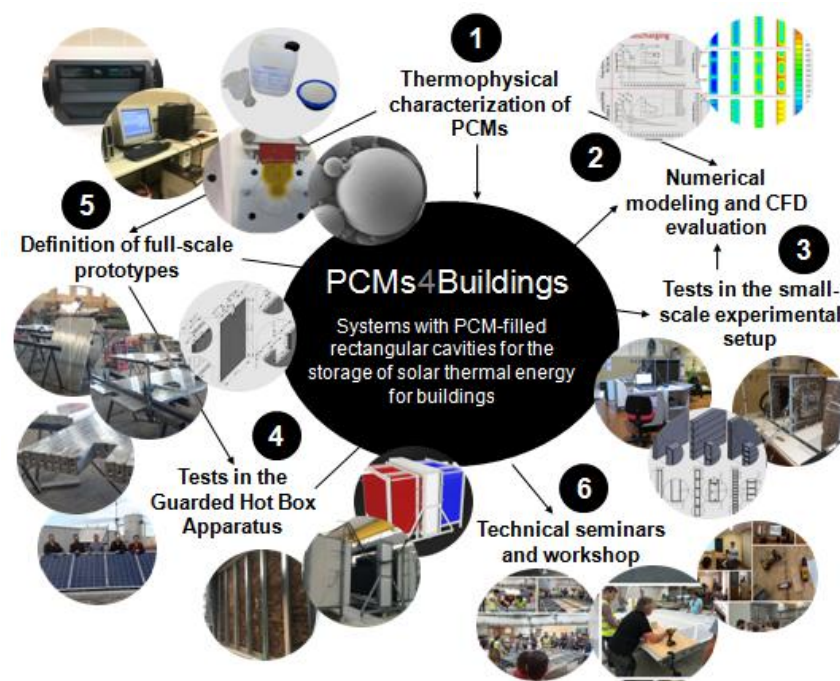

Figure 2. Dependencies and relationships among the main tasks of the project "PCMs4Buildings".

## Acknowledgements

This project is supported by FEDER funds through the COMPETE 2020 - POCI, and by Portuguese funds through FCT in the framework of the project POCI-01-0145-FEDER-016750 | PTDC/EMS-ENE/6079/2014.



## REFERENCES

- [1] N. Soares, J.J. Costa, A.R. Gaspar, P. Santos (2013), Review of passive PCM latent heat thermal energy storage systems towards buildings' energy efficiency, *Energy Build* 59 (2013) 82-103.
- [2] N. Soares (2015), *Thermal energy storage with phase change materials (PCMs) for the improvement of the energy performance of buildings*, PhD Dissertation in Sustainable Energy Systems, Department of Mechanical Engineering, FCTUC, 2015.
- [3] [www.adai.pt/pcms4buildings](http://www.adai.pt/pcms4buildings).

## PROS AND CONS OF DIFFERENT CALORIMETRIC METHODOLOGIES APPLIED TO PCM IN BUILDING APPLICATIONS

Mónica Delgado<sup>1\*</sup> and Ana Lázaro<sup>1</sup>

<sup>1</sup> Aragón Institute for Engineering Research (I3A), Thermal Engineering and Energy Systems Group, University of Zaragoza, Betancourt Building, C/ María de Luna, 50018, Zaragoza, Spain

\* Corresponding author: Mónica Delgado, monica@unizar.es

**Keywords:** Thermal Energy Storage, PCM granules, Packed bed, DSC, T-history.

**Abstract** *The present research analysed the complementarity of different measuring methodologies for the enthalpy-temperature curve determination of a granular PCM composite, commonly used in building applications. Specifically, the enthalpy variation of the GR31 product has been measured by using: 1) An energy balance calculation of an air stream flowing through a GPCC packed bed; 2) a DSC; 3) the T-history method. The energy balance setup gave an accurate measurement of the enthalpy variation within a sufficiently high temperature interval. Obtaining a representative sample was not a problem using this method, in contrast to the DSC which requires a greater number of tests to obtain an average value representative of the packed bed. However, the energy balance method does not enable the direct determination of the enthalpy-temperature curve. The T-history methodology allows the enthalpy to be determined based on temperature while the representativeness problem of the DSC is avoided due to higher sample volume. Nevertheless, the sample must be altered, crushed and subsequently compacted to reduce the effects of the thermal resistances provoked by the void spaces being filled by air.*

### 1. INTRODUCTION

Shape stable phase change materials (PCM) are currently being developed to enable the integration of thermal energy storage in buildings at different geometries. It is one of the most promising solutions due to their incorporation into building components. The main characteristics for designing purposes are melting and solidification temperature, density, enthalpy variation between the operating temperatures, thermal conductivity and long term stability of the compound. Granular PCM composites (GPCC) are shape stable PCM and they are of considerable interest for thermal energy storage systems due to the possibility of direct contact between the heat transfer fluid and the GPCC, which can also lead to better heat transfer rates while taking advantage of small particle diameters. These composites provide a flexible solution that can be used in several applications. On the one hand, they can be integrated with air heat exchangers. On the other hand, PCM granules can be integrated into building composite materials. Characterization of the phase changing behaviour of granular materials is an important issue for the design and optimization of latent thermal energy storage systems. However, PCM embedded into granular porous solids may present barriers when measuring enthalpy-temperature curves. The present study aims to evaluate the

suitability of these three measuring methodologies – DSC, T-history and air energy balance – for the enthalpy-temperature curve determination of GPCC.

## **2. MATERIALS**

The product GR31, supplied by the manufacturer Rubitherm, has been characterized. These granules have a particle size between the range of 1–3 mm, where paraffin is absorbed, representing a mass fraction of approximately 35%, inside a porous mineral structure which contains diatom.

## **3. METHODOLOGY**

### **3.1. DSC**

The present work adopts the methodology for characterizing PCM with a DSC proposed by Lázaro et al. [1]. To analyse the representativeness problem of the sample, two different approaches have been followed with regard to the sample preparation. On the one hand, granules with a flat surface were taken as samples to be measured, placing the flat face on the crucible base to avoid an elevated thermal contact resistance. On the other hand, PCM granules were crushed and subsequently compacted in the aluminium crucible, the quantity being equivalent to that of one whole granule.

### **3.2. T-history**

Crushed samples were compacted in the sample holder of the T-history set-up. The temperature has been measured at the surface of the sample holder, since according to the Mazo et al.'s study [2], who theoretically analyzed the conduction transfer process inside T-history samples, the deviation in phase change enthalpy is negligible.

### **3.3. Air energy balance installation**

The experimental installation previously developed by Dolado et al. [3] has been used for these measurements as it allows the measurement of the enthalpy variation of a packed bed of granular PCM contained inside a glass tube. The air flow temperature is measured at the air inlet and outlet sections. Additionally, the surface temperature of the glass container is measured at three points by type T thermocouples. The air volumetric flow is measured by a thermal mass flow controller (Bronkhorst, EL-FLOW).

## **4. CONCLUSIONS**

Table 1 shows the main advantages and disadvantages associated with the determination of the enthalpy-temperature curve of GPCC by comparing the different experimental methodologies. The comparison has shown that there is no single valid methodology for characterizing the phase change behaviour of PCM granules.



Table 1. Main characteristics of experimental methodologies for evaluating enthalpy variations in GPCC

Method	Sample mass [g]	Sample form		Advantages	Disadvantages
		Granules	Crushed granules		
DSC	0,02	Yes	Yes	h-T curve is obtained	If the granule is measured without being crushed, an appropriate sampling must be done. This will lead to a long experiment to get representative results.
				Crushed samples can be measured to reduce the sampling	The crushed sample preparation can modify phase change temperature
T-history	8-25	No	Yes	Bigger sample sizes, which means a more representative sample.	Sample must be crushed and compacted to avoid temperature gradients inside the sample.  Thermal conductivity of the compacted crushed granules cannot be measured in order to estimate Biot number
E.B. setup	30	Yes	No	Sample representativeness  The model from which the energy variation of PCM is measured is based on a simpler hypothesis than the DSC and T-history methods.	h-T curve cannot be measured. Only the enthalpy variation in a temperature interval.  Experimental conditions, especially temperature levels, have a high influence on the accuracy of measurements. Thus, the quality of the measurement limits the temperature interval

## REFERENCES

- [1] A. Lazaro, C. Peñalosa, A. Solé, G. Diarce, T. Haussmann, M. Fois, B. Zalba, S. Gschwander, L.F. Cabeza (2013), Intercomparative tests on phase change materials characterisation with differential scanning calorimter, *Appl Energy* 109 (2013) 415-420.
- [2] J. Mazo, M. Delgado, A. Lázaro, P. Dolado, C. Peñalosa, J.M. Marín, B. Zalba (2015), A theoretical study on the accuracy of the T-history method for enthalpy-temperature curve measurement: analysis of the influence of thermal gradients inside T-history samples, *Meas Sci Technol* 26 (12) (2015) 125001 (10pp)
- [3] P. Dolado, I. Miranda, J.S. Urieta, J. Coronas, A. Lázaro (2014), Packed bed zeolite experimental setup to study TCS systems up to 200°C, *Eurosun 2014*, Aix-les Bains, France.

## THERMOPHYSICAL CHARACTERIZATION OF COMMERCIAL PARAFFIN-BASED PCMS FOR LOW TEMPERATURE THERMAL ENERGY STORAGE APPLICATIONS

Telma Matias<sup>1</sup>, Nelson Soares<sup>2,3</sup>, Isabel Campos-Gonçalves<sup>1</sup>, José J. Costa<sup>2</sup>,  
Pedro N. Simões<sup>1</sup> and Luísa Durães<sup>1\*</sup>

<sup>1</sup> CIEPQPF, Department of Chemical Engineering, University of Coimbra,  
Rua Sílvio Lima, 3030-790 Coimbra, Portugal

<sup>2</sup> ADAI, LAETA, Department of Mechanical Engineering, University of Coimbra,  
Rua Luís Reis Santos, 3030-788 Coimbra, Portugal

<sup>3</sup> ISISE, Department of Civil Engineering, University of Coimbra,  
Rua Luís Reis Santos, 3030-788 Coimbra, Portugal

\* Correspondent author: L. Durães, luisa@eq.uc.pt

**Keywords:** PCMs, thermophysical characterization, modulated DSC, TPS method, specific heat, thermal conductivity.

**Abstract** *Reliable data on the thermophysical properties of commercial Phase Change Materials (PCMs) is fundamental for the design and modelling of low temperature Thermal Energy Storage (TES) applications. However, data provided by manufacturers is often insufficient and uncertain. In this work, an experimental study was conducted to determine the relevant thermophysical properties of some commercial paraffin-based PCMs, providing a valuable and useful database for ongoing and future studies. Two types of PCMs were evaluated, both microencapsulated and in free-form. Latent heat of fusion, specific heat and melting/solidification temperatures were measured by Modulated Differential Scanning Calorimetry (MDSC). High-resolution modulated thermogravimetric analysis (HiRes-MTGA) was also used to evaluate the thermal stability of the tested PCMs. For the thermal conductivity/diffusivity, the Transient Plane Source (TPS) method (HotDisk) was used. The importance of eliminating phase-transition interferences in the measurements and the effect of the polymer shell in the properties of microencapsulated PCMs were analysed. Properties of both type of PCMs were compared, for the same paraffin composition.*

### 1. INTRODUCTION

The improvement of energy efficiency of buildings is an imposed area of research, with the market/governments demand for new systems that reduce buildings dependency on fossil fuels, by using renewable sources, matching supply and demand (energy storage), while improving indoor thermal comfort in a more sustainable and cost effective way. In this line, PCMs play an important role, contributing for both energy savings and solar energy profit. The assessment of thermophysical properties of PCMs, in particular their change with temperature and physical state, is crucial for the design/modelling of their application in TES, although challenging for conventional techniques.

Cabeza *et al.* [1] reviewed the conventional and unconventional technologies available

for the thermophysical characterization of PCMs. Nowadays, the techniques most commonly used to determine the thermal properties of PCMs are the (conventional) DSC - dynamic and step methods – and the T-history method. In this work, Modulated DSC was used to evaluate the specific heat, the enthalpy curve, the latent heat and the melting/solidification temperatures for several commercial PCMs. The thermal conductivity and diffusivity were evaluated by the TPS method (ISO 22007-2 [2]) from Hot Disk.

## 2. EXPERIMENTAL

Table 1 summarizes the commercial PCMs studied in this work. Their thermal conductivities/diffusivity was measured using a *Hot Disk TPS 2500 S* equipment in the range 0–50°C. Regarding the evaluation of the specific heat, latent heat of fusion and enthalpy change with temperature, a MDSC equipment from *TA Instruments (Q100* model) was used. The thermal stability of the samples was also analysed by HiRes-MTGA with a *TA Instruments Q500* equipment. Finally, the microstructure of microencapsulated PCMs was assessed by a Field Emission Scanning Electron Microscope, model *Merlin Compact/VPCompact FESEM*, from *Zeiss*.

Table 1. Commercial PCMs used in this work ( $T_{p,m}$ : melting peak temperature).

PCM Ref. <sup>(a)</sup>	Sample form	$T_{p,m}$ / °C	Manufacturer (Supplier)
PCM 18	Bulk	18	Microtek laboratories
PCM 24	Bulk	24	Microtek laboratories
PCM 28	Bulk	28	Microtek laboratories
RT 25 HC	Bulk	25	Rubitherm
RT 28 HC	Bulk	28	Rubitherm
MPCM 18D	Microencapsulated	18	Microtek Laboratories
MPCM 24D	Microencapsulated	24	Microtek Laboratories
MPCM 28D	Microencapsulated	28	Microtek Laboratories
Micronal® DS 5001 X	Microencapsulated	26	BASF

(a) PCM 18/24/28 use the same paraffin of MPCM 18D/24D/28D, respectively.

## 3. RESULTS AND CONCLUSIONS

Figures 1 and 2 show representative results of thermal conductivity and specific heat. It is notorious that the thermal conductivity of free-form PCMs is always higher and more differentiated than that of microencapsulated PCMs, which is more pronounced in the solid state. The polymeric component of microencapsulated PCMs contributes to a more regular value in both solid and liquid states, near  $0.1 \text{ W}\cdot\text{m}^{-1}\cdot\text{°C}^{-1}$ . This lower value may reduce the efficiency of this kind of PCMs, since it hinders the heat transfer. Regarding the specific heat results, the influence of the polymer in the broadness and maximum of the peaks during phase transition is noticeable. The position of the peaks of  $C_p$  is consistent with the temperature indicated by the suppliers for the phase change (Table 1), although slightly lower in all cases. Moreover, the phase transition occurs in a wide temperature range.

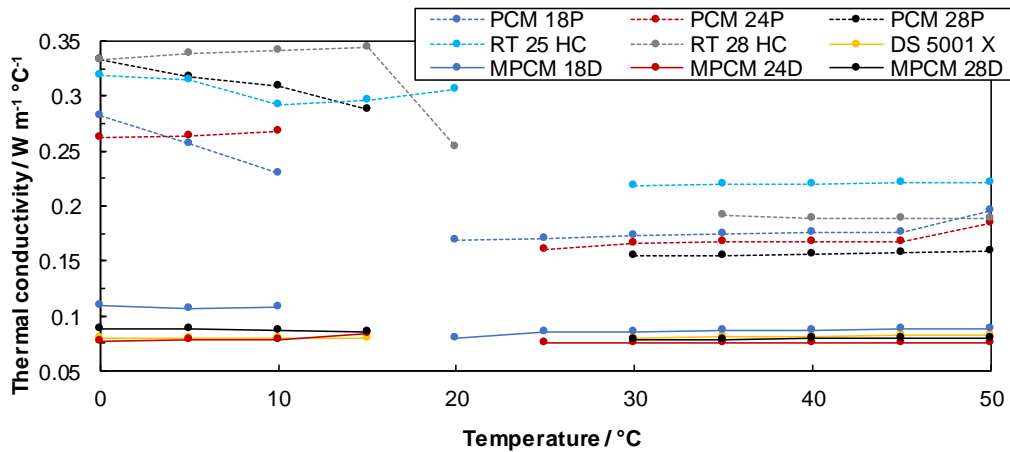

Figure 1. Thermal conductivities of commercial PCMs measured by the TPS method (Hot Disk).

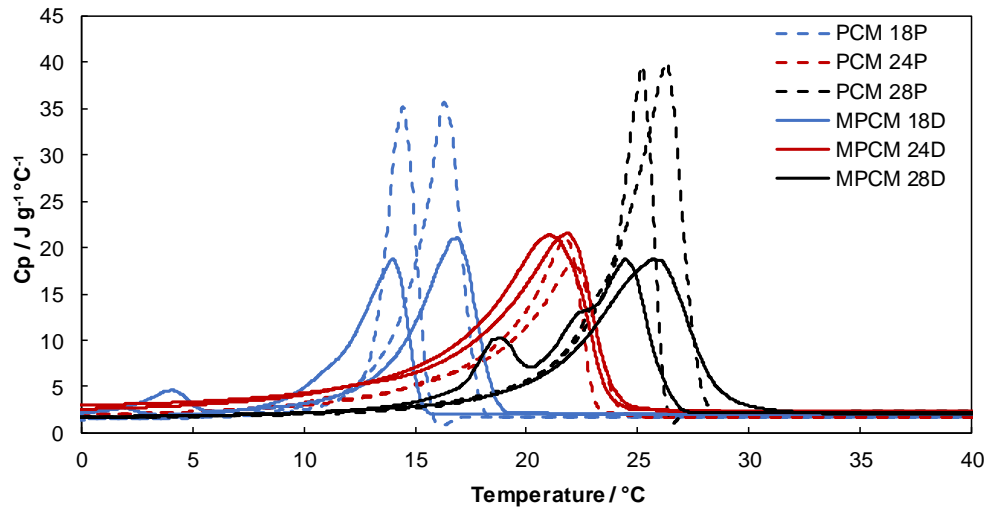

Figure 2. Specific heat of commercial PCMs measured by MDSC (rate: 2 °C min<sup>-1</sup>).

## Acknowledgements

This project is supported by FEDER funds through the COMPETE 2020 - POCI, and by Portuguese funds through FCT in the framework of the project POCI-01-0145-FEDER-016750 | PTDC/EMS-ENE/6079/2014.



## REFERENCES

- [1] L.F. Cabeza *et al.* (2015), Unconventional experimental technologies available for phase change materials (PCM) characterization. Part 1. Thermophysical properties, *Renew Sustain Energy Rev* 43 (2015) 1399-1414.
- [2] International Standard ISO 22007-2, *Plastics – Determination of thermal conductivity and thermal diffusivity – Part 2: Transient plane heat source (hot disk) method*, 2008.

# THE IMPORTANCE OF THE THERMOPHYSICAL CHARACTERIZATION OF MICROENCAPSULATED PCMS FOR THE NUMERICAL ANALYSIS OF THE HEAT TRANSFER WITH SOLID-LIQUID PHASE CHANGE

N. Soares<sup>1,2\*</sup>, A. Luzio<sup>1</sup>, T. Matias<sup>3</sup>, P.N. Simões<sup>3</sup>, L. Durães<sup>3</sup> and J.J. Costa<sup>1</sup>

<sup>1</sup> ADAI, LAETA, Dep. of Mechanical Engineering, University of Coimbra, Coimbra, Portugal

<sup>2</sup> ISISE, Dep. of Civil Engineering, University of Coimbra, Coimbra, Portugal

<sup>3</sup> CIEPQPF, Dep. of Chemical Engineering, University of Coimbra, Portugal

\* Correspondent author: Nelson Soares, nelson.soares@dem.uc.pt

**Keywords:** Phase change materials (PCMs), microencapsulated PCM, thermal energy storage (TES), numerical modelling; effective heat capacity method; additional heat source method.

**Abstract** *This work presents the development of two-dimensional numerical models based on the “additional heat source” and the “effective heat capacity” methods to simulate the thermal behaviour of a microencapsulated phase change material (PCM) - Micronal<sup>®</sup> DS 5001 X. A purely diffusive, transient model was used, where conduction is the only heat transfer mechanism during phase change. Different ways are evaluated to specify the variation of the equivalent heat capacity with temperature during the solid-liquid phase change: triangular and rectangular profiles, and also the experimentally measured specific heat as a function of temperature. The formulation of the triangular profile was based on previous studies of the authors, where a deficit of total stored/released energy was observed although predicting reasonably well the phenomena kinetics. This time, a new, consistent triangular profile method is used and its application can be generalized to different materials, by a single adjustment to the thermophysical characteristics of the PCM. This new formulation, designated as “triangular adjusted profile”, proved to be the most effective method, showing the best agreement with the previous experimental data obtained by the authors. The microencapsulated PCM is used to fill the rectangular cavities of an aluminium made thermal energy storage (TES) unit. Three different configurations of the TES unit were evaluated, in order to assess the influence of the number of aluminium fins in the PCM bulk. The melting/solidification time and the energy stored/released by the PCM were also evaluated for the different configurations. In general, the numerical results achieved are in good agreement with the experimental data previously obtained by the authors.*

## 1. INTRODUCTION

The incorporation of PCMs in small TES units (also called heat sinks) has been a subject of great interest and much work has been developed worldwide [1]. These TES units are typically made of a high-conductivity internally-finned container used to accommodate the PCM and to compensate the low thermal conductivity of paraffins, commonly used as PCMs. To prevent liquid leakage, the metallic container can be the only way of containment,

otherwise the PCM can be microencapsulated before filling the macrocapsule. The main advantage of using TES units filled with microencapsulated PCMs is that the problem of liquid leakage during manufacturing, assembling and operation can be significantly reduced. When dealing with microencapsulated PCMs, the numerical modelling of the heat transfer with phase change becomes simpler, as the advection phenomena in the melted domain can be neglected [2] and the energy conservation equation (in its purely diffusive form) is the only governing equation to be solved.

This paper presents the validation of 2D numerical models developed in a homemade FORTRAN program and based on the *additional heat source method* and the *effective heat capacity method* to evaluate the heat transfer with melting/solidification of a microencapsulated PCM – Micronal® DS 5001 X – contained in vertical modules of rectangular-section cavities. The experimental results found in refs. [2,3] are used to validate the numerical models. The main goal of this work is to evaluate which method is better to simulate the heat transfer with solid-liquid phase change. This study also aims to assess which kind of function for the variation of the effective heat capacity with temperature is more suitable to simulate the kinetics of the phase change processes and to determine the stored/released energy during a charging/discharging cycle.

It should be remarked that the product datasheet of the majority of PCMs does not specify all the thermophysical properties in both solid and liquid phases, which is crucial for numerical modelling. When an effort is carried out to match experimental and numerical results many uncertainties related to the measurements and several numerical errors have to be considered. This is not easy to do in standard thermal analyses, but it is even harder to do when a material changes its phase in time with the variation of temperature. Moreover, the characterization of PCMs is essential to provide reliable data for modelling. In this work, the authors also aim to experimentally evaluate the main thermophysical properties of the microencapsulated PCM used in the experiments, namely the specific heat of both solid and liquid phases, the latent heat and melting temperature, and the thermal conductivity.

## 2. METHODOLOGY

### 2.1. Experimental results used for numerical validation purposes

The experimental data obtained by Soares *et al.* [2,3] are used for the purpose of validating the numerical simulation. The temperatures on the surfaces of the TES unit measured during the experiments are considered as dynamic boundary conditions in the numerical study. In the laboratory setup shown in Figure 1, the TES unit has a fixed position and it is thermally insulated on its border smaller faces, such that only the right and left square bigger surfaces will be thermally active. On its left side, a heating module holding a 68 W electrical resistance (the hot-plate) is tightly fixed to perform charging processes. During charging, a thermal insulation board is placed on the rear (right) side of the TES unit to ensure adiabatic conditions. To carry out discharging processes, a cooling module holding a heat exchanger fed by a thermo-regulated water flow (the cold-plate – 14 °C) is tightly placed on the right side of the TES unit, while a thermal insulation board is placed on the left side of the TES unit to ensure adiabatic conditions. Twenty-one K-type thermocouples were distributed on the right and left surfaces of the TES unit, respectively, to record the time evolution of temperature on both faces. Five K-type thermocouples are also positioned on the mid-plane of the TES unit to measure the temperature evolution within the PCM domain. Further details about the experimental setup, instrumentation and procedure can be found in refs. [2,3].

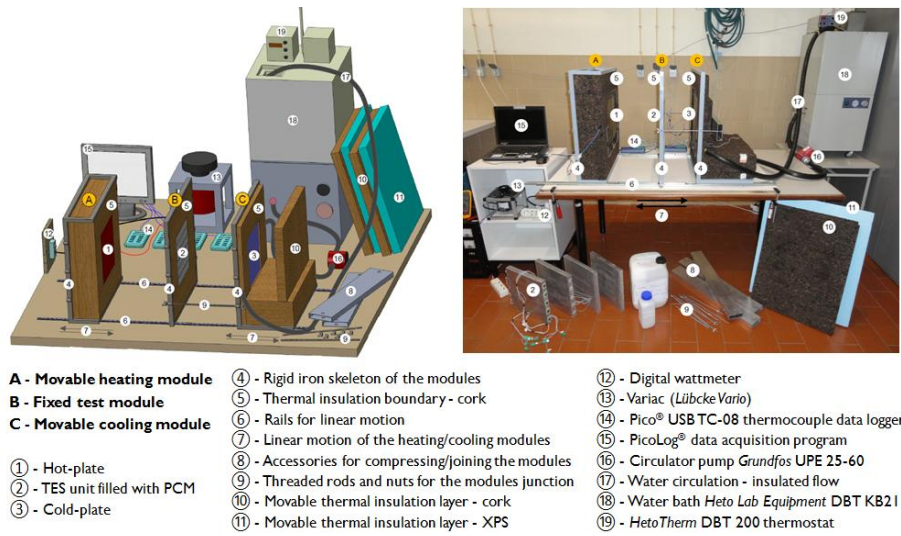

Figure 1. Sketch and photographic view of the experimental setup. Adapted from refs. [2,3].

Figure 2a shows a sketch of the 1-single cavity TES unit whose central cross section is the 2D physical model considered in the simulations. In the numerical model, the boundary conditions imposed on the vertical surfaces reproduce the time evolution of the average temperature measured on the left and right faces of the TES unit during the experiments,  $TH(t)$  and  $TC(t)$  respectively. The top and bottom frontiers are set to be adiabatic.  $T_i$  ( $i = 1$  to 5, from top to bottom) are the temperatures of the PCM measured in the mid-line of the central cross section of the TES unit. The time evolution of  $T_i$  experimentally obtained is used for numerical validation purposes. To evaluate the influence of the aspect ratio of the cavities during melting and solidification processes, as well as the influence of adding metallic fins, three different configurations of the TES unit are considered, as shown in Figure 2, with the  $T_i$  temperatures measured or calculated at the same positions in every configuration.

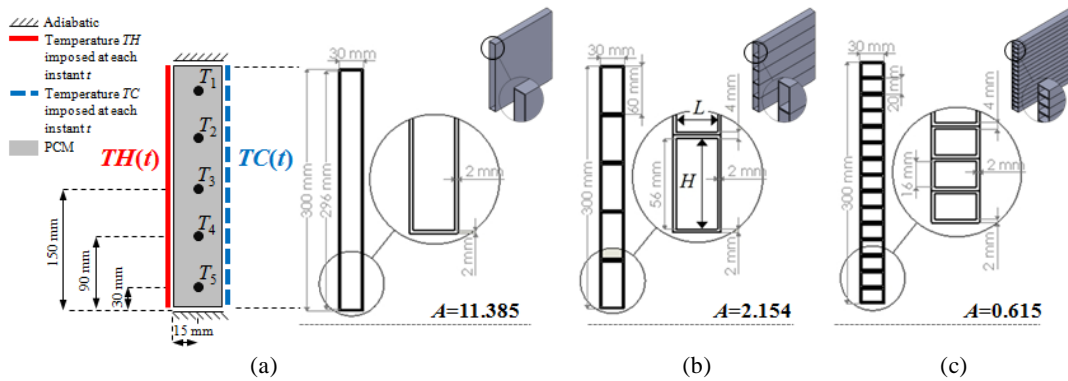

Figure 2. (a) Sketch of the physical model and specified boundary conditions for the 1-single cavity TES unit ( $A=11.385$ ). Sketch and dimensions of the TES units with (b) 5-cavities ( $A=2.154$ ) and (c) 15-cavities ( $A=0.615$ ). Figure adapted from refs. [2,3].

## 2.2. Thermophysical properties of the PCM

Figure 3a shows the evolution of the thermal conductivity of the PCM with temperature, and Figure 3b shows the specific heat of the PCM measured by MDSC with a charging rate of  $2\text{ }^\circ\text{C}/\text{min}$ . Regarding thermal conductivity, the values measured of about  $0.08\text{--}$

$0.086 \text{ W}\cdot\text{m}^{-1}\cdot\text{°C}^{-1}$  are 2.3–2.5 times lower than those typically specified in the literature for organic PCMs ( $\approx 0.2 \text{ W}\cdot\text{m}^{-1}\cdot\text{°C}^{-1}$ ). The peak of  $C_p$  is consistent with the temperature indicated by the suppliers. However, the phase transition occurs in a wide temperature range, which must be considered in the numerical simulations. The volumetric mass density was estimated for each experiment – about  $489\text{--}538 \text{ kg/m}^3$ . These values are 40–115% higher than those specified in the datasheet of the material (about  $250\text{--}350 \text{ kg/m}^3$ ), which can significantly affect the numerical predictions.

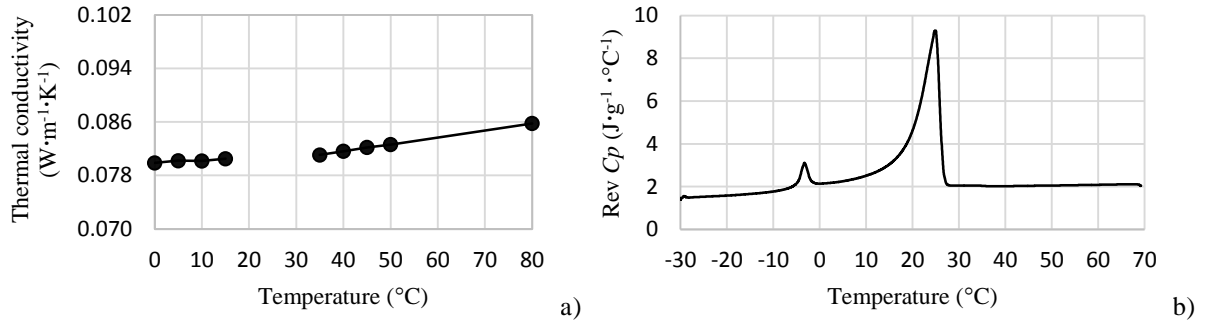

Figure 3. (a) Variation of the thermal conductivity of the PCM with the evolution of temperature – measurements with the Hot Disk TPS 2500 S equipment. (b) Specific heat of the PCM measured by Modulated Differential Scanning Calorimetry (MDSC) – the TA Instruments Q100 model was used (charging rate:  $2 \text{ °C/min}$ ).

### 2.3. Numerical simulation approach

The numerical models are based on the *additional heat source method* (AHS) and the *effective heat capacity method*. In the former, the latent heat is treated in the source term of the energy conservation equation in its purely diffusive form. In the second method, the latent heat is modelled in the energy conservation equation as an artificially inflated specific heat within the temperature interval where phase change occurs. Five profiles for the variation of the effective heat capacity with temperature were considered:

- Rectangular profiles (Figure 4a) –  $\square$ ;
- Triangular profile (Figure 4b) –  $\Delta$ ;
- Triangular corrected profile ( $2L$ ) –  $\Delta^*$  ( $\Delta T_1=7\text{°C}$ ,  $\Delta T_2=2\text{°C}$ );  $\Delta^{**}$  ( $\Delta T_1=4\text{°C}$ ,  $\Delta T_2=2\text{°C}$ );
- Triangular adjusted profile (Figure 4c) –  $\Delta_{adj}$  (varying  $\Delta T_1$  and  $\Delta T_2$  automatically).

The so-called *reverse  $C_p$  method* (RevCp) was also used, *i.e.*, the specific heat as a function of temperature obtained experimentally was considered in the simulation (Figure 3b).

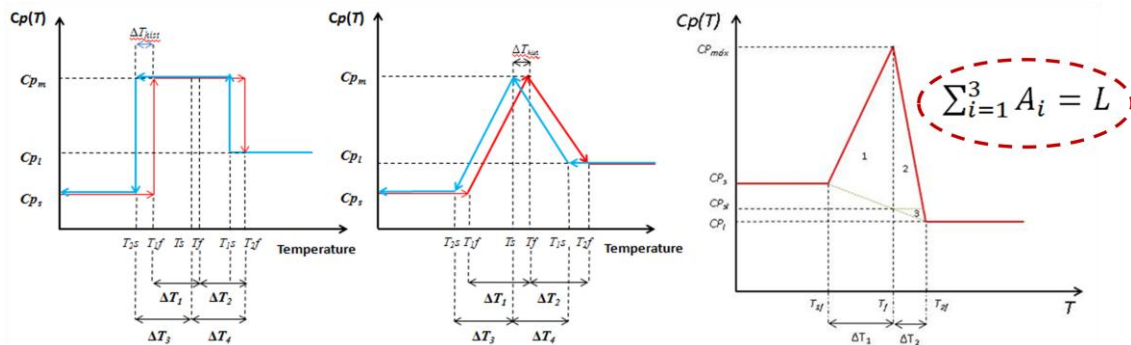

Figure 4. Sketch of the *effective heat capacity method* considering different artificial approximations for the variation of the effective heat capacity with temperature: (a) rectangular profile; (b) triangular profile; (c) triangular adjusted profile.



### 3. RESULTS AND DISCUSSION

The results of the parametric study carried out, considering all the methods mentioned above for the three configurations of the TES unit, can be found in ref. [4]. In this section, only some representative results are presented.

Figure 5 shows the time evolution of  $T_{5,num}$  calculated with the *additional heat source method* (AHS) and with different approximations of the effective heat capacity (rectangular and triangular adjusted profiles, and *reverse  $C_p$  method*) in comparison with  $T_{5,exp}$ , considering a unidirectional model. The results show that the approaches based on the *effective heat capacity method* suit better the kinetics of the charging process. In fact, it was concluded that further research has to be carried out in order to improve the AHS and RevCp numerical approaches.

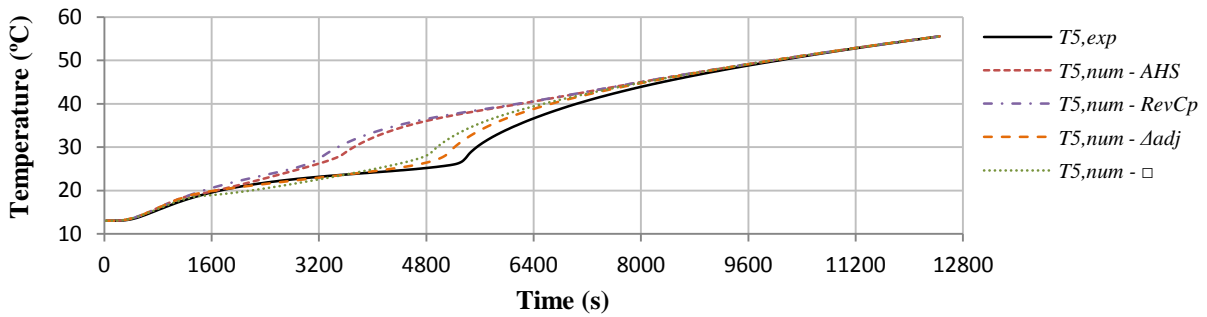

Figure 5. Unidirectional model – time evolution of  $T_{5,num}$  calculated with different numerical methods in comparison with  $T_{5,exp}$  (1-single cavity).

Figure 6 shows the time evolution of the boundary conditions specified during charging ( $TH$  and  $TC$ ), and the evolution of  $T_{1,num}$  calculated with different approximations of the effective heat capacity in comparison with  $T_{1,exp}$ , considering a unidirectional model. Figure 1 shows that both  $\square$ ,  $\Delta^*$  and  $\Delta_{adj}$  profiles suit well the kinetics of the charging process. However, Table 1 shows that the profile that better estimates the stored energy during charging is the triangular adjusted profile.

Figure 7 shows the results of the 2D model for the 5-cavities TES unit, during charging and discharging. The triangular adjusted profile was used in the 2D simulations. Figure 8 shows the time evolution of both the temperature distribution and the melted fraction of PCM during charging and discharging.

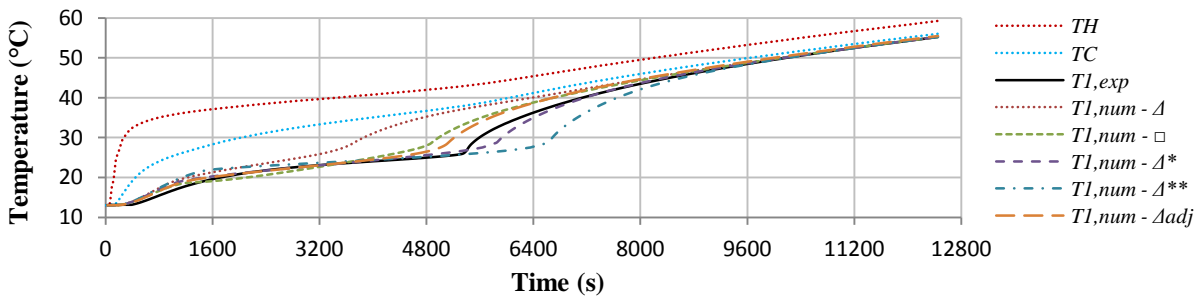

Figure 6. Unidirectional model – time evolution of the boundary conditions specified during charging; evolution of  $T_{1,num}$  calculated with different approximations in comparison with  $T_{1,exp}$  (1-single cavity).

Table 1. Comparison between the theoretical stored energy and the values obtained with different approximations of the effective heat capacity.

	Approximations of the effective heat capacity				
	$\Delta$	$\square$	$\Delta^*$	$\Delta^{**}$	$\Delta_{adj}$
Stored Energy – $E$ (kJ)	7.7	10.1	11.4	12.4	9.5
Theoretical Stored Energy (kJ)			9.8		
ER $T_{1,num}$ (%)	10.4	4.4	2.0	5.4	3.4
ER $E$ (%)	20.9	3.7	17.0	27.5	3.1

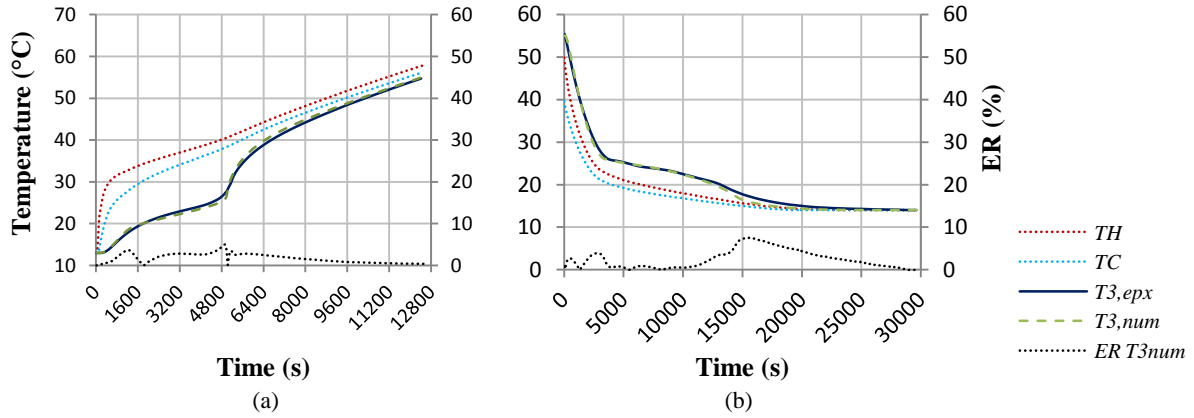

Figure 7. 2D model / 5-cavities TES unit – time evolution of the specified boundary conditions and time evolution of  $T_{3,num}$  calculated with the triangular adjusted profile in comparison with  $T_{3,exp}$  during (a) charging and (b) discharging.

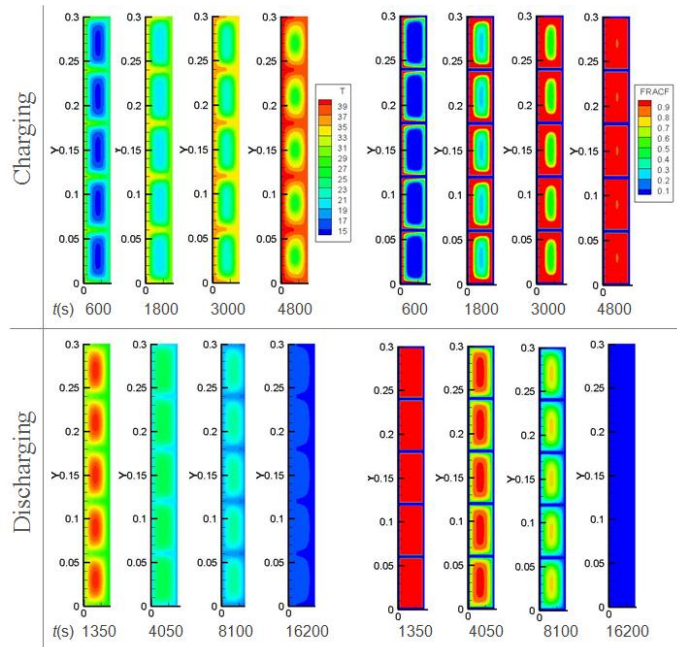

Figure 8. Time evolution of both the temperature distribution and the melted fraction of PCM during charging and discharging – 5-cavities TES unit.

### 3. CONCLUSION

In this paper, previous experimental results were used to validate homemade numerical

models based on the *additional heat source method* and the *effective heat capacity method* to simulate the thermal behaviour of a microencapsulated PCM - Micronal® DS 5001 X. Five approximations of the effective heat capacity were investigated: two triangular and a rectangular profile, the specific heat as a function of temperature obtained experimentally, and a new formulation designated as triangular adjusted profile. It was concluded that the last formulation is the most effective method, showing better agreement with the experimental results.

### Acknowledgements

This project is supported by FEDER funds through the COMPETE 2020 - POCI, and by Portuguese funds through FCT in the framework of the project POCI-01-0145-FEDER-016750 | PTDC/EMS-ENE/6079/2014.



### REFERENCES

- [1] N. Soares, J.J. Costa, A.R. Gaspar, P. Santos (2013), Review of passive PCM latent heat thermal energy storage systems towards buildings' energy efficiency, *Energy Build* 59 (2013) 82-103.
- [2] N. Soares, A.R. Gaspar, P. Santos, J.J. Costa (2015), Experimental study of the heat transfer through a vertical stack of rectangular cavities filled with phase change materials, *Appl Energy* 142 (2015) 192-205.
- [3] N. Soares, A.R. Gaspar, P. Santos, J.J. Costa (2016), Experimental evaluation of the heat transfer through small PCM-based thermal energy storage units for building applications, *Energy Build* 116 (2016) 18-34.
- [4] A. Luzio (2018), *Análise comparativa de diferentes métodos para a modelação numérica do comportamento de materiais de mudança de fase (PCMs) microencapsulados*, Master thesis in Mechanical Engineering, University of Coimbra, 2018.

## ASSESSMENT OF LATENT HEAT STORAGE OF PCM-MORTARS: A CASE STUDY USING A FULL-SCALE EXPERIMENTAL TEST

S.S. Lucas<sup>1\*</sup>

<sup>1</sup> Department of the Built Environment, Eindhoven University of Technology, Netherlands

\* Correspondent author: Sandra S. Lucas, s.s.d.o.lucas@tue.nl

**Keywords:** Phase change materials (PCMs), PCM-mortars, full-scale experiments.

**Abstract** *The combination of phase change materials (PCM) and traditional renders have been extensively studied – however, most studies are limited to the laboratory scale. Full-scale experiments, that simulate more realistically the service conditions, are still required to validate and transfer research into commercial products. In this work, several PCM-mortars using cement, lime and gypsum as binders, have been studied – an optimised composition was then selected for the scale-up test. It was demonstrated that the addition of PCM in mortars allows the material to retain heat, with a positive impact in the overall energy demand of a building. There is a combined effect of delay and lowering of temperature peaks, triggered by the heat released from the capsules. The room with PCM showed not only a smaller temperature gradient between night and day, it also exhibited lower peaks. The use of the room-size test cells proves that PCM can be successfully mixed into mortars to create a new type of wall coating – capable of reducing energy demand in buildings.*

### 1. INTRODUCTION

Increasing cost on energy prices and raising concerns with environmental impact of construction has put pressure in industry to seek solutions that can reduce the life cycle impact of buildings. The application of phase change materials (PCM) in building's structures and products had been subject to extensive research, due to its potential for reducing heating and cooling needs within buildings [1–3].

PCM can store a high amount of energy per mass of material and latent heat storage occurs at an almost constant temperature. They suffer very low volume changes, therefore making it a very interesting material for incorporation into mortar composites. Latent heat transfer that occurs at the phase change temperature is a direct result of the PCM's melting/solidifying process. Latent heat storage is then dependent on the enthalpy change and can be determined using Eq. 1, where  $\Delta H$  is the enthalpy variation (J), and  $m$  is the material mass (g).

$$\Delta Q = m \times \Delta H \quad (1)$$

### 2. MATERIALS

The mortar compositions were prepared using three commercial binders: hydrated lime, Portland cement CEM II 32.5N and gypsum. A siliceous sand was used as fine aggregate. To reduce the water content while maintaining workability, 1 wt. % of a superplasticizer,

MasterGlenium 51 from BASF was added to all mixes.

The phase change material (Micronal DS 5008) comprises a paraffin mixture encapsulated in a polymethylmethacrylate (PMMA) shell, with an average particle size of 6  $\mu\text{m}$ , transition temperature of 23  $^{\circ}\text{C}$  and enthalpy of 135 kJ/kg. The mortars tested contained different PCM amounts: 0, 10, 20 and 30 wt. % of total solids.

### 3. EXPERIMENTAL

For the laboratory tests, it was developed a set-up aiming to mimic as closely as possible the real service conditions. Small-scale test cells coated on the inside with a mortar layer of 3 mm and made with an insulating material were assembled. Thermocouples placed inside the cells and connected to a data acquisition system measured the temperature continuously during the test. The experimental setup can be seen in Figure 1. It was established a temperature cycle with a minimum of 10 $^{\circ}\text{C}$  and maximum of 40 $^{\circ}\text{C}$ , with a steady-state period of 10 minutes at the maximum and minimum value. The intention was to trigger the PCM phase transition (occurring between 23 and 25  $^{\circ}\text{C}$ ) to assess the effect of the heat storage and heat release when the temperature rises or falls throughout the cycle.

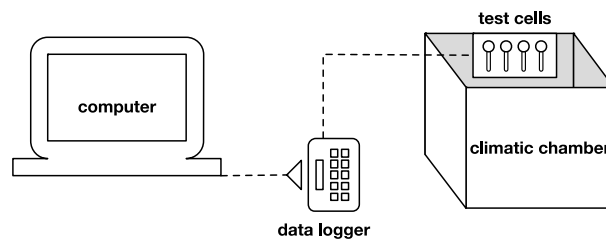

Figure 1. Schematic drawing for the laboratory set-up.

The full-scale tests were conducted at the testing facilities at the University of Minho, in room-size test cells specifically designed for tests with PCM-mortars [4]. One of the cells contains the reference mortar with no PCM added and the second contains the PCM-mortar. The mortars were applied in the interior side of a brick wall with 11 cm thickness. Several temperature sensors were glued to the walls before the application of the final mortar coating. Another set of thermocouples was placed between the base layer and the final finishing sheet of mortar – this finishing coating is the only one containing PCM. The external temperature and the ambient temperature inside each cell were also monitored.

### 4. DISCUSSION

The results for the tests performed at the laboratory using a climatic chamber are presented on Figure 2. It is clear that, regardless the binder used, the mortars with PCM are able to delay temperature peaks and able to reduce the overall temperature inside the room. It is interesting to note that lime based mortars are amongst the most efficient, showing lower peaks – especially during the night. The lime-cement mortar is the only composition where the 20 wt. % PCM shows higher efficiency than the 30 wt. %. The explanation for both phenomena are detailed in a previous publication [5]. It has been proven that internal microstructure plays an important role in PCM-mortars – not only influences the mechanical strength, it also affects the heat storage efficiency.

While selecting the composition for the real scale experiment – since mechanical performance is very important for the durability of the mortar – the above-mentioned previous work was taken into account. Thus, by looking at both strength and heat storage, the

composition elected for this test was the lime-gypsum mortar with 20 wt. % of PCM. This composition showed a good compromise between hardened state durability, workability, heat storage efficiency and cost.

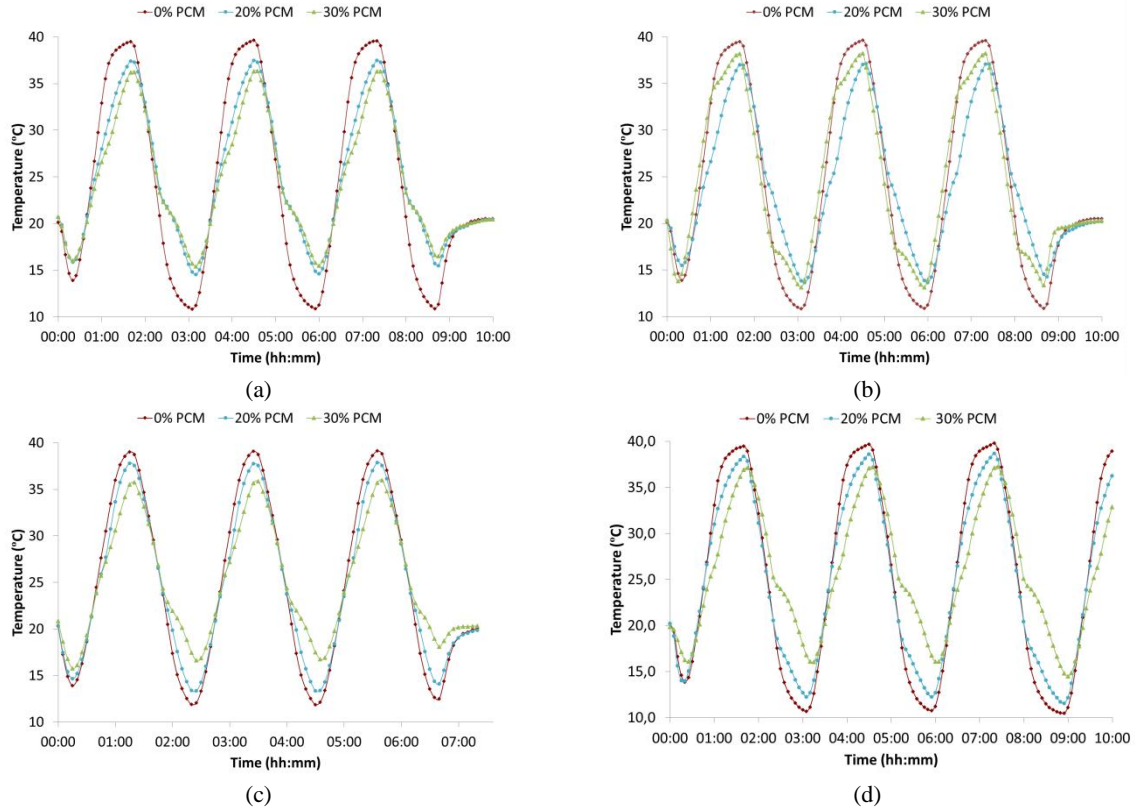

Figure 2. Results for tests performed within the laboratory chamber: (a) cement, (b) cement-lime, (c) lime and (d) lime-gypsum

Figure 3 shows the results obtained with the full-scale test cells. It is noticeable the difference between the temperature inside the reference room and the room with the PCM coating. While there are peaks of 37 °C in the former, the latter does not show any higher than 26 °C, even during the summer period when the test was performed.

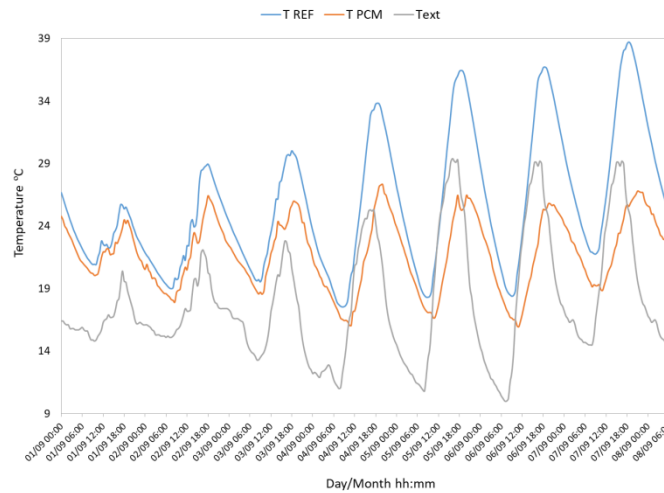

Figure 3. Results for tests performed on room size cells.

## 5. CONCLUSIONS

In conclusion, it has been demonstrated that mortars containing PCM can be an effective solution to lower the energy demand in buildings. After a careful optimisation process conducted in laboratorial conditions, it was possible to develop a composition that works in a real service simulation. More research, combining full-scale tests and modelling, is however required to properly validate and provide industry with an effective commercial product.

## REFERENCES

- [1] M. Kheradmand, M. Azenha, J.L.B. de Aguiar, K.J. Krakowiak (2014), Thermal behavior of cement based plastering mortar containing hybrid microencapsulated phase change materials, *Energy Build* 84 (2014) 526–536.
- [2] N. Soares, J.J. Costa, A.R. Gaspar, P. Santos (2013), Review of passive PCM latent heat thermal energy storage systems towards buildings' energy efficiency, *Energy Build* 59 (2013) 82–103.
- [3] V.V. Rao, R. Parameshwaran, V.V. Ram (2018), PCM-mortar based construction materials for energy efficient buildings: A review on research trends, *Energy Build* 158 (2018) 95–122.
- [4] G. Cattarin, F. Causone, A. Kindinis, L. Pagliano (2016), Outdoor test cells for building envelope experimental characterisation – A literature review, *Renew Sustain Energy Rev* 54 (2016) 606–625.
- [5] S.S. Lucas, V.M. Ferreira, J.L.B. de Aguiar (2013), Latent heat storage in PCM containing mortars - Study of microstructural modifications, *Energy Build* 66 (2013) 724–731.

## USE OF PCMs IN POLYURETHANE FOAM LAYERS: FROM THE INDIVIDUAL LAYER TO BUILDING SOLUTIONS

R. Vicente<sup>1\*</sup>, C. Amaral<sup>1</sup>, P. Marques<sup>2</sup> and A. Barros-Timmons<sup>3</sup>

<sup>1</sup> RISCO, Department of Civil Engineering, University of Aveiro, Campus Universitário de Santiago, 3810-193 Aveiro, Portugal

<sup>2</sup> TEMA, Department of Mechanical Engineering, University of Aveiro, Campus Universitário de Santiago, 3810-193 Aveiro, Portugal

<sup>3</sup> CICECO, Aveiro Institute of Materials, Department of Chemistry, University of Aveiro, Campus Universitário de Santiago, 3810-193 Aveiro, Portugal

\* Correspondent author: Romeu da Silva Vicente, Tel.: +351 234 370 845,  
Fax: +351 234 370 094, romvic@ua.pt

**Keywords:** Hot box heat flux meter, microencapsulated phase change material (mPCMs), rigid polyurethane foams (RPU), thermal conductivity.

**Abstract** *The use of thermal insulation materials is the most effective passive measure of energy savings in buildings. Rigid polyurethane foams (RPU) are commonly used as the insulation layers of opaque building envelope solutions, as well as for other applications in field of transportation, textile industry and electrical appliances, accounting for almost one-third of the polyurethane market. In the assessment of the energy performance of buildings, insulation materials, such as RPU foams have good insulating properties – low thermal conductivity – however their thermal regulation capacity can be enhanced by the incorporation of phase change materials (PCMs). Herein, three different approaches (flux meter approach, the guarded hot plate approach and the transient plane source approach) are presented to determine the thermal conductivity of RPU foams with and without the incorporation of PCMs based on steady state method and transient method, particularly in the temperature range during PCMs phase change transition (solid/liquid state).*

### 1. INTRODUCTION

One of the most used solutions, to improve the thermal behaviour of building envelopes and enhance the building indoor thermal regulation, is the use of thermal insulation materials. Compared with others known typically insulating materials, the RPU are highly competitive, because their good thermal and physical properties, such as: (i) low thermal conductivity, (ii) high mechanical and chemical stability and (iii) their compatibility and easy form to be incorporated into others facing materials [1]. Therefore, besides of the good insulation properties that the RPU foams have, their thermoregulation capacity can be improved using PCMs [2–5]. In this case, the introduction of PCMs will provide an extra heat capacity to the building solution, storing and releasing more energy and keeping the good RPU thermal properties [1].

Typical thermal conductivity values for PU foams are between 0.02 and 0.05W/mK and variation of the thermal conductivity values is related to several factors. Zhang *et al.* [7]



presented an experimental study of the thermal conductivity of PU foams under various environments, discussing the effect of factors such as temperature, humidity, water uptake, alternate high and low temperature, long time storage at high temperature and gas pressure of the atmosphere. For instance, they have concluded that thermal conductivity of PU foam increases non-monotonically with temperature and increases as high as 10–18% in moist air. Estravís *et al.* [8] studied the relationship between cellular structure and thermal conductivity of the RPU foams with infused nanoclays. The thermal conductivity of the foam is reduced after the addition of nanoclays. Marcovich *et al.* [9] showed that the unfavourable changes of thermal conductivity was an effect of the foam's cellular structure, mainly attributed to the closed cell content that decreases as the amount of the palm oil-based bio-polyol in the formulation increases.

According to most references, there are many different forms to estimate and calculate the thermal conductivity, however these forms can be divided into two main methods: the steady-state and transient (non-steady-state) method [10–12]. To estimate the thermal conductivity using the steady-state method, the temperature imposed to the material surface is kept constant, so does not change over time. One advantage of this method is the simple and direct signal analysis. For the calculation of the thermal conductivity using the transient method, the measurements are made during a variable heating process. The sensor imposes a small electric signal in the specimen and the distribution of this signal is analysed and measured. Hereafter, the thermal conductivity is calculated using math approaches, so this method is more difficult to be done [6,11,13].

The main aim of this work is to give new insights on the thermal conductivity measurements of RPU foams with PCMs using three different approaches, especially in the temperature range during mPCM phase change transition (solid/liquid state). To evaluate the influence of mPCMs incorporation in the RPU foam in terms of the thermal conductivity, the selected experimental characterization tests were: (i) hot box heat flux meter approach, (ii) guarded hot plate approach, and (iii) transient plane source approach.

## 2. MATERIALS AND FOAMS

The Microencapsulated PCM powder purchased from BASF (Ludwigshafen, Germany) was used in this study, (Micronal®DS 5001X). It contains paraffin wax with a melting point of 26°C as the core material and a shell of PMMA (polymethyl methacrylate). The polyurethane (PU) components Purotherm 463 RG 48 (polyol) and puronate 900 (isocyanate) of the PU foam formulation were purchased from Rühl Puromer GmbH (Friedrichsdorf, Germany). The polyol component includes different proportions of bio-polyols, catalyst and stabilizers. Melamine (99 %) was purchased from SIGMA ALDRICH (Munich, Germany) as a fine powder.

The standard PU foam was prepared using 100 parts of polyol (Purotherm 463 RG 48) and 130 parts of isocyanate (puronate 900). Both components were mixed for 10 seconds with a blade stirrer at 2000 rotations/second. The PCM (up to 12.5 parts = 5%) and flame retardant (melamine) were incorporated in the polyol fraction prior to the PU foam formation by mixing for 55 sec. To avoid high shear forces, a blade stirrer with a lower rotation rate (1000 rotations/second) that does not touch the bottom of the beaker was used.

To evaluate the influence of PCMs (Micronal®DS 5001X) in the PU foam layer, the following experimental characterization tests were carried out over 2 specimens:

- Rigid PU foam with melamine and without PCM (designated as RPU);
- Rigid PU foam with melamine and with 5wt% PCM (designated as RPU\_5PCM).

To characterize the energy storage properties of the pristine microencapsulated PCM

(mPCM) and RPU\_5PCM foam specimens (melting and solidification temperature and enthalpy), a dynamic scanning calorimeter (DSC 4000, PerkinElmer) was used, at a heating and cooling rate of 1°C/min, in the range of 10°C to 50°C under a nitrogen atmosphere. Table 1 summarizes the results of specific heat capacity versus temperature for the mPCM and RPU\_5PCM foam specimens and the latent heat,  $\Delta H$  (J/g) values for melting and solidification curves.

Table 1. DSC results of the mPCM and RPU\_5PCM foam specimens

Specimens	Melting			Solidification		
	Transition temperature	Melting temperature	Melting latent heat	Transition temperature	Solidification temperature	Solidification latent heat
	$T_{t,m}$ (°C)	$T_m$ (°C)	$\Delta H_m$ (J/g)	$T_{t,s}$ (°C)	$T_s$ (°C)	$\Delta H_s$ (J/g)
mPCM	25.36	27.55	97.85	25.94	25.19	96.33
RPU_5PCM	22.31	23.54	6.16	22.87	22.30	5.96

### 3. MAIN RESULTS

The comparative analysis between the three test approaches for thermal conductivity measurements was for RPU foams with and without mPCM at the 10 °C (mPCM solid state), 25 °C (mPCM solid/liquid phase change) and 40 °C (mPCM liquid state). In the case of the HB-HFM approach the thermal conductivity measurements were taken as the mean specimen surface temperature at 11.6 °C (mPCM solid state), 25.6 °C (mPCM solid/liquid phase change) and 39.5 °C (mPCM liquid state). The results are shown in Figure 1 for the three approaches. The results do not take into account correction factors, according to the ISO 10456, since the main target is to compare in relative terms the results from the different measurement approaches.

The results show that the enhancement in thermal conductivity of the RPU foams with and without mPCM increased with temperature. Using the HB-HFM approach and GHP approach, the value of the thermal conductivity of the RPU foam with mPCM comparatively to the RPU foam without mPCM is lower in respect to the TPS approach. However, the addition of the mPCM does not seem to have significant influence on the thermal conductivity of the RPU foams, because the variance on the thermal conductivity (in relation of the RPU foam without mPCM) obtained for the mPCM solid state was approximately -1.78% for the HB-HFM approach, -0.85% for the GHP approach and 4.97% for the TPS approach.

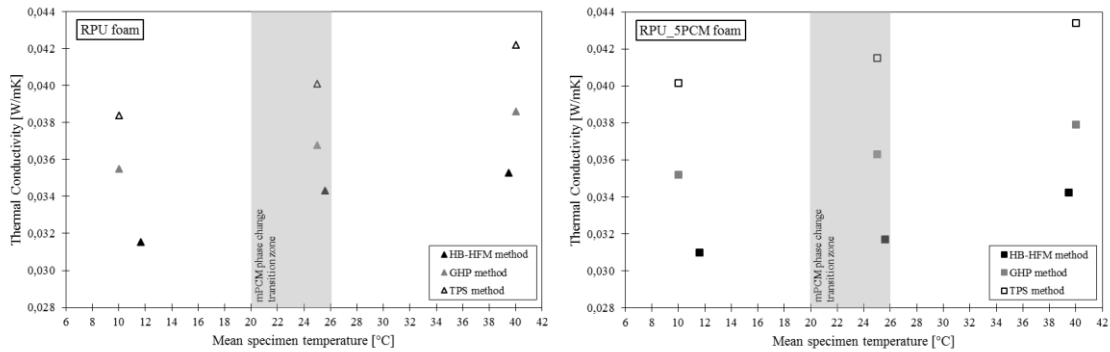

Figure 1. Comparison of thermal conductivity at 10°C, 25°C and 40°C for all approaches.

### 4. CONCLUSIONS

The present study highlights the evaluation and comparison of the thermal conductivity of

RPU foams with and without mPCMs using three different approaches: i) the thermal flux meter approach (steady-state method), ii) the guarded hot plate (GHP) approach and iii) the transient plane source (TPS) approach (transient methods). The results showed that the three approaches present similar values of thermal conductivity for temperatures below and above the mPCM phase change transition zone (variance on the thermal conductivity between  $-1.81\%$  and  $4.97\%$ ), however during the mPCM phase change transition zone there are important factors that should be considered to determine the thermal conductivity. Nevertheless, the TPS approach presents the higher values of thermal conductivity values for the RPU foams with and without mPCM. The following main conclusions taken from the presented research are:

- The temperature had a similar influence on thermal conductivity (increase) of the RPU foam with and without mPCM when in solid and liquid state. However, the value of the thermal conductivity decreases with the presence of the mPCM in the RPU foams using the HB-HFM and GHP approaches. In exception of the TPS approach, the value of the thermal conductivity slightly increases with the presence of the mPCM in the RPU foams;
- During mPCM phase change transition a decreasing trend of the thermal conductivity with the increasing temperature is observed. The temperature range of the solid/liquid phase of the RPU 5PCM foam was about  $22\text{--}24\text{ }^{\circ}\text{C}$ , but part of the RPU foam would experience phase change when temperature rises from  $20\text{ }^{\circ}\text{C}$  to  $26\text{ }^{\circ}\text{C}$ ;
- The thermal conductivity of the RPU foam with mPCM was simultaneously influenced by the temperature increase as well as by the phase change fraction of the mPCM. This behaviour was clearly observed using the HB-HFM and TPS approach, because in these two approaches the experiments involved measuring the thermal conductivity of the specimens at different temperatures in the range  $2\text{--}40\text{ }^{\circ}\text{C}$  (range temperature that represent all the mPCM phases);
- The most important advantage of the use of HB-HFM approach for thermal conductivity measurements is that the thickness and dimensions of the specimens can be higher than the other approaches. On the other hand it is recommended to use more than one heat flux meter on each side of the specimen;
- Using the GHP approach, the influence of the addition of mPCM into RPU foams on the thermal conductivity could not be observed, since the measurements were made only for temperatures  $10\text{ }^{\circ}\text{C}$ ,  $25\text{ }^{\circ}\text{C}$  and  $40\text{ }^{\circ}\text{C}$ . One important factor is the measurement temperature which must be representative of all mPCM phases (solid, solid/liquid and liquid phase). Also, the unevenness of the specimen surface is identified as another major source of error;
- The TPS approach has some constrains for the thermal conductivity measurements with specimens incorporating mPCMs. The measurement is a combination of energy being transferred through the material and the energy stored or released in the phase change. The thermal conductivity is slightly affected and can be estimated by interpolating from a point before to a point after the phase change;
- The three approaches presented a good correlation of the experimental data to calculate the thermal conductivity of RPU foams with and without PCMs, when in the liquid and solid state, but some testing constraints and factors were identified when determining the thermal conductivity of the specimens for the phase change zone. It is important to try a quantitative analysis of the simultaneous influence on the thermal conductivity of temperature rise as well as the phase change fraction of the mPCM incorporated during the phase change zone;
- Overall, the measurement campaign confirmed that the HB-HFM approach gives more

reliable thermal information on the RPU foams with mPCM.

Promising results have been achieved but there is still a long path to go in terms of thermal conductivity measurements of the RPU foams with mPCMs, particularly during mPCM phase transition stage using steady-state and transient methods. It is important to identify the coupling effect of the temperature rise and the phase change fraction of the mPCM on the thermal conductivity value. This study is interesting and that is worth considering further studies on behaviour of the thermal conductivity values during the PCMs phase change transition.

### Acknowledgments

The present work was developed under the scope of the project: MF-Retrofit – Multifunctional facades of reduced thickness for fast and cost-effective retrofitting [EeB.NMP.2013-1 Grant Agreement to: 609345].

### REFERENCES

- [1] N. Sarier, E. Onder (2007), Thermal characteristics of polyurethane foams incorporated with phase change materials, *Thermochim Acta* 454 (2) (2007) 90–98.
- [2] Y.G. Bryant, D.P. Colvin, Moldable foam insole with reversible enhanced thermal storage properties, in, Google Patents (1996).
- [3] M.L. Nuckols (1999), Analytical modeling of a diver dry suit enhanced with micro-encapsulated phase change materials, *Ocean Eng* 26 (6) (1999) 547–564.
- [4] M. You, X.-X. Zhang, X.-C. Wang, L. Zhang, W. Wen (2010), Effects of type and contents of microencapsulated n-alkanes on properties of soft polyurethane foams, *Thermochim Acta* 500 (1-2) (2010) 69–75.
- [5] C. Yang, L. Fischer, S. Maranda, J. Worlitschek (2015), Rigid polyurethane foams incorporated with phase change materials: a state-of-the-art review and future research pathways, *Energy Build* 87 (2015) 25–36.
- [6] S.A. Al-Ajlan (2006), Measurements of thermal properties of insulation materials by using transient plane source technique, *Appl Therm Eng* 26 (17-18) (2006) 2184–2191.
- [7] H. Zhang, W.-Z. Fang, Y.-M. Li, W.-Q. Tao (2017), Experimental study of the thermal conductivity of polyurethane foams, *Appl Therm Eng* 115 (2017) 528–538.
- [8] S. Estravís, J. Tirado-Mediavilla, M. Santiago-Calvo, J.L. Ruiz-Herrero, F. Villafañe, M.Á. Rodríguez-Pérez (2016), Rigid polyurethane foams with infused nanoclays: Relationship between cellular structure and thermal conductivity, *Eur Polym J* 80 (2016) 1–15.
- [9] N.E. Marcovich, M. Kuranska, A. Prociak, E. Malewska, K. Kulpa (2017), Opencell semi-rigid polyurethane foams synthesized using palm oil-based bio-polyol, *Ind Crops Prod* 102 (2017) 88–96.
- [10] C. Buratti, E. Belloni, L. Lunghi, M. Barbanera (2016), Thermal conductivity measurements by means of a new ‘small hot-box’ apparatus: Manufacturing, calibration and preliminary experimental tests on different materials, *Int J Thermophys* 37 (5) (2016) 37–47.
- [11] Y. He (2005), Rapid thermal conductivity measurement with a hot disk sensor: Part 1. Theoretical considerations, *Thermochim Acta* 436 (1-2) (2005) 122–129.
- [12] S.A. Memon (2014), Phase change materials integrated in building walls: a state of the art review, *Renew Sustain Energy Rev* 31 (2014) 870–906.
- [13] X. Wang, H. Yu, L. Li, M. Zhao (2016), Research on temperature dependent effective thermal conductivity of composite-phase change materials (PCMs) wall based on steady-state method in a thermal chamber, *Energy Build* 126 (2016) 408–414.

## INCORPORATION OF PHASE CHANGE MATERIALS (PCM) IN CERAMICS FOR BUILDING APPLICATIONS

Hélio Jorge<sup>1\*</sup>, Rui Novais<sup>2</sup>, Sónia Bastos<sup>3</sup>, Paula Seabra<sup>2</sup> and João Labrincha<sup>2</sup>

<sup>1</sup> Centro Tecnológico da Cerâmica e do Vidro (CTCV), Parque Tecnológico de Coimbra (Coimbra iParque), Lote 7, Antanho – Coimbra, Portugal

<sup>2</sup> Materials and Ceramic Engineering Department, CICECO, University of Aveiro, Campus Universitário de Santiago, 3810-193 Aveiro, Portugal

<sup>3</sup> CINCA - Companhia Industrial de Cerâmica, SA, Rua Principal, 39, 4509-908 Lourosa - Fiães, Portugal

\* Correspondent author: Hélio Jorge, hrjorge@ctcv.pt

**Keywords:** Ceramic material, ceramic Tiles, Phase Change Materials (PCM), porosity.

**Abstract** *The application of phase change materials (PCM) in building materials is an emerging field, aiming to improve the energy efficiency of buildings. This article presents part of the work of developing methods for the incorporation of PCMs in ceramic materials for application in the construction. The tests performed show the variability in the incorporation ratio of the PCM incorporation process in materials with different pore sizes and porosities, indications of conditions where there is higher incorporation and some critical differences between the two methods. Thermal testing of ceramic tiles in porcelain and earthenware have demonstrated the influence of the thermal storage of PCM when incorporated in tiles, as also to preview the energy savings in buildings.*

### 1. INTRODUCTION

The need for the improvement energy efficiency has been a motivation for the search for improvement of buildings. Therefore, buildings have been designed to reduce the energy consumption and to smart control of the inner temperature. The use of PCMs in building application is emergent and responds with great potential to this issues.

The use of PCMs with melting point in 20–40 °C range makes possible to obtain storage and release effect for the thermal comfort in buildings, with more significance for: thermal energy storage and thermal insulation.

In this work one proposes the production of ceramic materials for building with a new functionality of the PCM energy storage. Incorporation of PCM in porous materials has been tested in some materials like concrete, plaster or polymeric foam, it has not been found yet references to incorporation in ceramic materials [1,2].

### 2. EXPERIMENTAL METHODS

Experiments of PCM incorporation in ceramic tiles was carried, by diffusion through the porosity of the sintered ceramic material. Ceramic test tile were composed by a body with two layers in porcelain earthenware (Figure 3), a think dense layer and a thick porous layer. Porosity was generated by organic agents [3,4]. Ceramic tiles produced with different porous former agent concentrations and particle sizes. Particle size is proportionally correlated with

the porous size generated, and the agent concentration is proportionally correlated with the porosity fraction. The indirect relationships are used to understand the PCM incorporation efficiency with the size and fraction of porous.

Two PCM incorporation methods were tested: infiltration of melted pure PCM through the porous layer – Rubitherm RT, 21°C melting point, 174 kJ/kg thermal energy storage – and infiltration under pressure of aqueous suspensions of PCM microcapsules – BASF Micronal 23°C melting point, with 100 kJ/kg heat storage capacity.

### 3. RESULTS AND DISCUSSION

The incorporation method based on pure PCM produce a wide variation of the porosity filling ratio (from 45% to 98%), and it is highly dependent to the porosity volume and the porous size (Figure 1). Therefore they must be considered for process optimization. The most filled material have higher porosity and higher porous size.

Infiltration of microencapsulated PCM was achieved under since capsules have similar dimension as the ceramic porous size. The filling ratio has reached 82% for porous earthenware produced with 25% of porous former of -500  $\mu\text{m}$ , so in specimens with the highest porosity and porous size (Figure 2).

In pure PCM materials the calculated storage capacity is higher than in encapsulated PCM in all samples, because in the latter only a fraction of PCM is infiltrated together with water (examples: material with porous former 250–425  $\mu\text{m}$  / 15% has 128 kJ/  $\text{m}^2$  Pure and 50 kJ/ $\text{m}^2$  Encapsulated; porous former 500  $\mu\text{m}$  / 25% has 280 kJ/ $\text{m}^2$  Pure and 90 kJ/ $\text{m}^2$  Encapsulated).

Figure 4 shows the PCM effect in the ceramic material, highlighting a delay in temperature curve when PCM is melted, in 23°C range. Delay is wider in higher thermal capacity samples, whereas there is more PCM incorporated. That test demonstrates the increase of thermal inertia of the ceramic material, but not by temperature increasing.

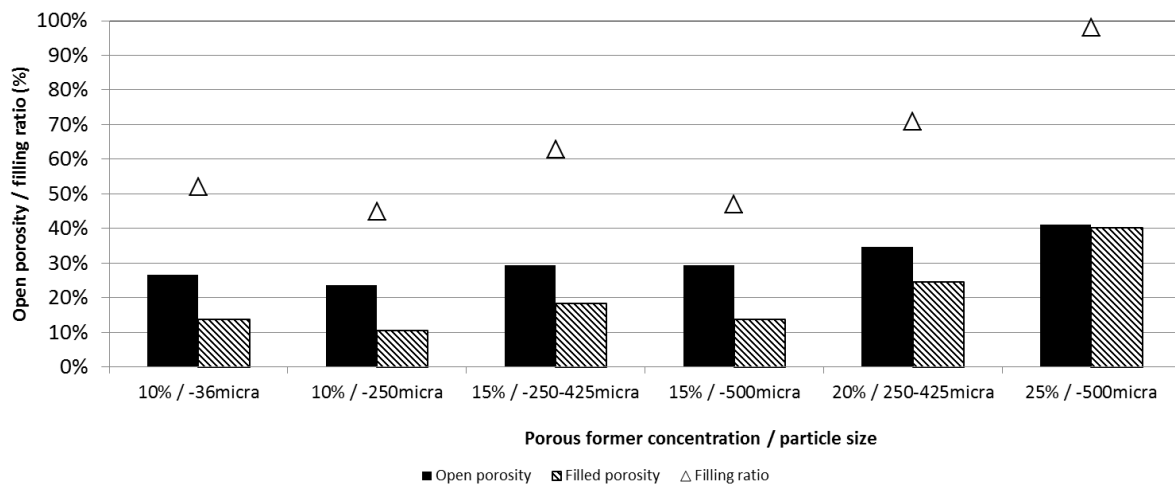

Figure 1. Filling ratio of pure PCM in porous porcelain earthenware tiles produced with different porous former compositions.

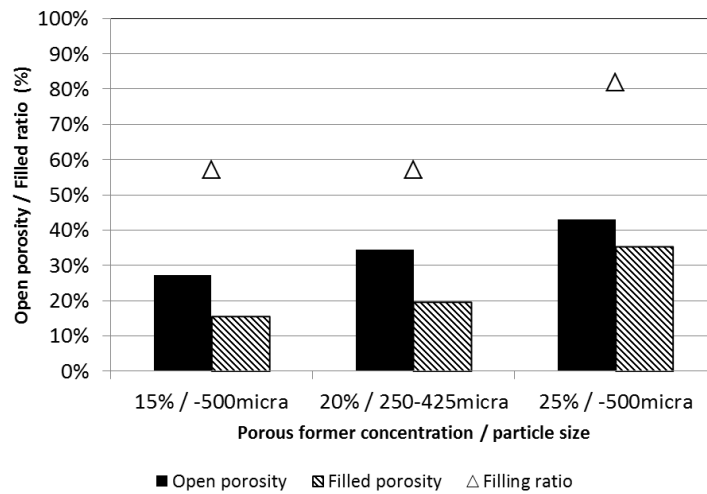

Figure 2. Filling ratio of microencapsulated PCM in porous porcelain earthenware tiles produced with different porous former compositions



Figure 3. Double layer dense-porous porcelain earthenware.

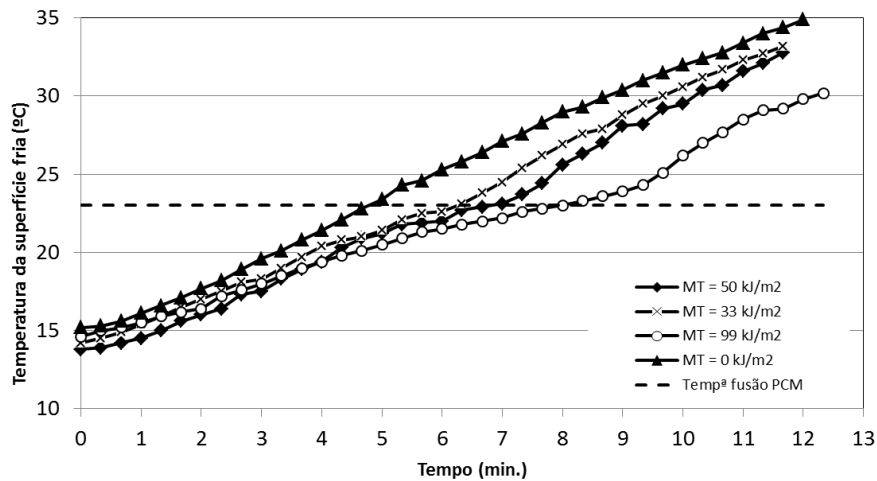

Figure 4. Heating curves of cold face temperature of ceramic tiles with different microencapsulated PCM amount.

### 3. CONCLUSIONS

This paper presents two methods for PCM incorporation in ceramic materials, using porosity to hold that material. Direct PCM incorporation and microencapsulated PCM was tested, able

to be applied according to different applications. PCM incorporation in ceramic tiles for building application has been demonstrated. This work shows that process optimization should be considered as the filling process efficiency is highly dependent on the porosity volume and porous size. A porcelain earthenware product was produced with a PCM energy storage capacity of 280 KJ/m<sup>2</sup> based on a double layer dense-porous material produced with -500 µm particle size and 25% body content porous former.

## REFERENCES

- [1] D.W. Hawes, D. Feldman (1992), Absorption of phase change material in concrete, *Sol Energy Mater Sol Cells* 27 (2) (1992) 91–101.
- [2] T. Lee, D.W. Hawes, D. Banu, D. Feldman (2000). Control aspects of latent heat storage and recovery in concrete. *Sol Energy Mater Sol Cells* 62 (3) (2000), 217–237.
- [3] R.M. Novais, M.P. Seabra, J.A. Labrincha (2014), Ceramic tiles with controlled and low thermal conductivity by using pore-forming agents, *Ceramic Int* 40 (8-A) (2014) 11673–11648.
- [4] R.M. Novais, M.P. Seabra, J.A. Labrincha (2015), Lightweight dense/porous bi-layered ceramic tiles prepared by double pressing, *J Mat Pro Tec* 216 (2015) 169–177.



## NEW SOLUTIONS FOR BUILDING ENVELOPE: BUILDING INTEGRATED PHOTOVOLTAIC SYSTEMS WITH INTEGRAL THERMAL STORAGE

Laura Aelenei<sup>1\*</sup>

<sup>1</sup> Laboratório Nacional de Energia e Geologia (LNEG), Lisbon, Portugal

\* Correspondent author: Laura Aelenei, laura.aelenei@lneg.pt

**Keywords:** Building integrated photovoltaic systems (BIPV), BIPV-PCM.

**Abstract** *During the last 20 years the research of Building Integrated Photovoltaic Systems (BIPV) related with different techniques and concepts has been widespread, but rather scattered. In BIPV systems photovoltaic panels functioning as an integral part of the building envelope, therefore, enhances the aesthetic appeal of the building. In addition of providing renewable energy, they may also contribute to improving the indoor climate when thermal energy released during the conversion process is withdrawn efficiently, passively or actively recovered (BIPV/T). The increase in BIPV/T research since 1990s, is a consequence of the growing interest of the construction industry in offering new alternatives to traditional approaches. The paper is reporting in the first part, a BIPV classification focused on the building integration aspect and on the characterization of the main parameters involved rather than on technologies used or the performance aspects. In the second part, the paper is focused on reporting the experimental results from a particular application, a case study developed in Portugal, where a thermal storage element, Phase Change Materials (PCM) integrates the BIPV.*

### 1. BIPV-PCM CASE STUDY

#### 1.1. Description of the system

A prototype BIPV-PCM has been designed and installed on the main façade of SolarXXI office building (Figure 1a) in Lisbon and since then is tested in real conditions (Figure 1b). Due to its high energy efficiency and solar energy system integration, SolarXXI present a nearly zero primary energy balance. The building was designed and prepared to work as a test facility, allowing the installation of the prototype on the façade (Figure 1a). The prototype under study consists of an outer layer (PV module) and an inner layer (gypsum wallboard incorporating PCM – Alba<sup>®</sup> balance with operating temperature of 23°C). In the case of BIPV-PCM (that is the case of the module integrating PCM in the gypsum board) during daytime, due to sun exposure, the PV panels absorbs the solar radiation, generating heat during conversion process, heat that is used for phase change material melting. During the nighttime, the melted PCM solidifies and delivers heat that keeps the panel warm for a prolonged period of time. The purpose of the BIPV-PCM and the expected behaviour is to keep the outside wall temperature warm (over 20°C), to prevent heat loss through the wall. The BIPV-PCM system is designed to be integrated with a building envelope and accumulate the thermal energy directly into the wall of the

building.



Figure 1. (a) Prototype installed on the SolarXXI main façade; (b) BIPV-PCM system.

## 1.2. Measurement campaign

The installation has been done in January 2013 and the sensors installation has been concluded in first part of February 2013. In this manner the first experimental results has been obtained in the second part of February. Interior and exterior temperatures as well as the solar radiation measurements are presented in Figure 2. In this work, some experimental results are presented. An analysis of thermal performance of the BIPV-PCM system has been developed, for two days with distinct climatic conditions, in order to estimate the behaviour of the system.

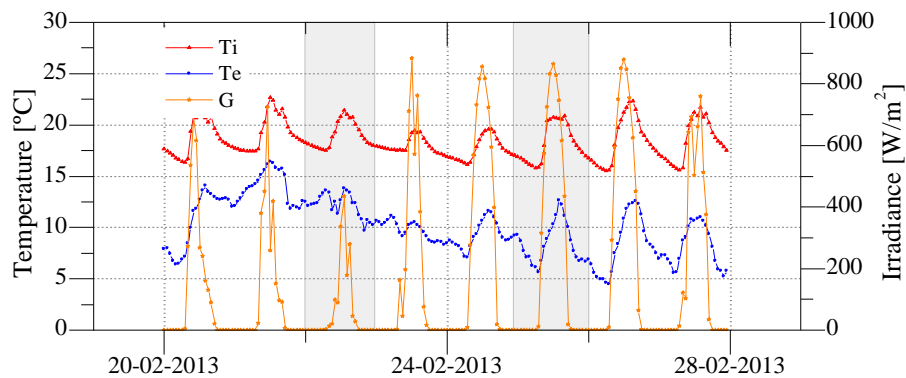

Figure 2. (a) Exterior, interior temperature and solar radiation measurements, Fev. 2013.

## 1.3. Experimental results

Cross section temperatures for the 22<sup>th</sup> and 25<sup>th</sup> of February 2013 are presented in Figure 3. The higher temperature differences at different hours of the day presents the PV module with about 12,5°C for the 22<sup>th</sup> and about 13,5°C for the 25<sup>th</sup>, the PCM presents a smaller difference temperature of about 2°C for the 22<sup>th</sup> and 4,5°C for the 25<sup>th</sup> at different hours of the day.

Fig. 4 represents the heat fluxes in the two days under consideration, where it is possible to observe a constant profile for the PCM interior layer on day 22<sup>th</sup>, and a delay in the energy transfer in the 25<sup>th</sup>, due to the phenomenon of absorption of energy in the form of latent heat.

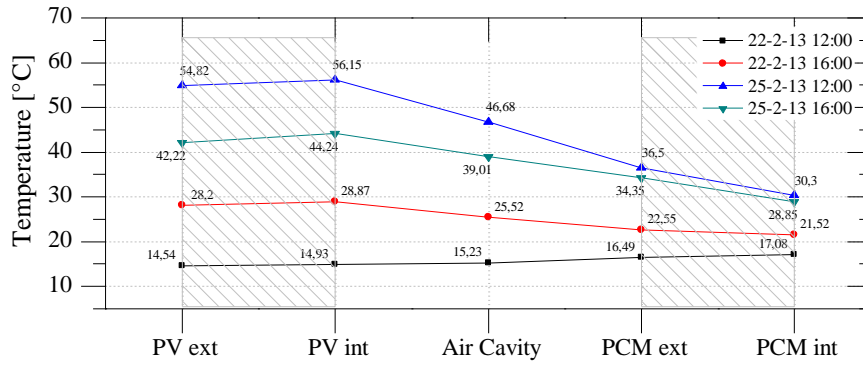
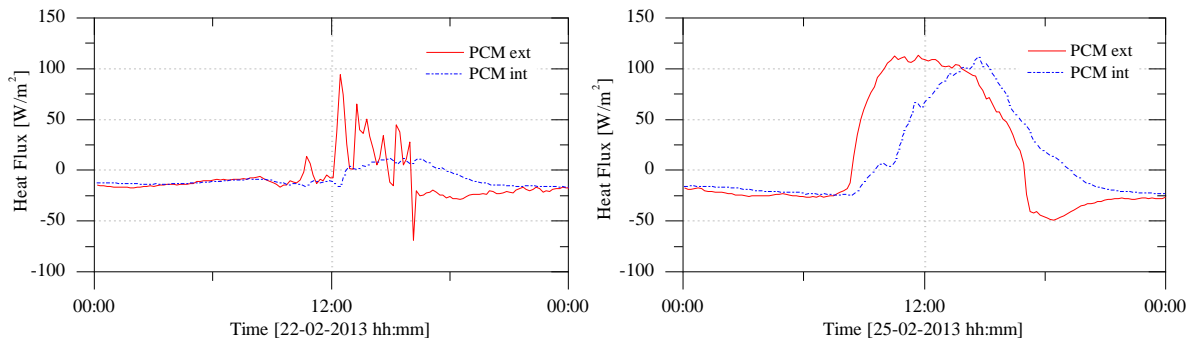

Figure 3. Cross section temperatures for the two different days.

Figure 4. PCM exterior and interior fluxmeter measurements, 22<sup>th</sup> and 25<sup>th</sup> Feb. 2013.

## 2. COST ANALYSIS

As the project propose the study and development of a new technology, the cost analysis is very important, especially comparing with other existing building façade solutions. For this reason a simplified analysis has been developed, where four different solutions/systems have been compared in terms of cost and energy demand impact of the using space. The systems under study were: an insulated brick wall, a traditional BIPV and the BIPV-PCM prototype with and without insulation. The cost methodology is taking into account the investment costs of each system component/material and the operation cost of a using space integrating the systems. As it can be observed in Figure 5, in terms of cost, the traditional solution of an insulated brick wall still has the lowest value. However, the same solution when integrated in the space wall, correspond to the highest energy demand of the space. The best solution in terms of reduction of space energy demand presents the BIPV and BIPV-PCM insulated, even the cost are elevated, because of the high cost of PV modules which represents aprox.83-85% of the total solution cost.

$$Costs = \left[ \sum_{i=1}^n A_i \times P_i \right] + \left[ (Q_{Energy}^{Necessary} - Q_{Energy}^{Produced}) \times P_{Energy} \right] \quad (1)$$

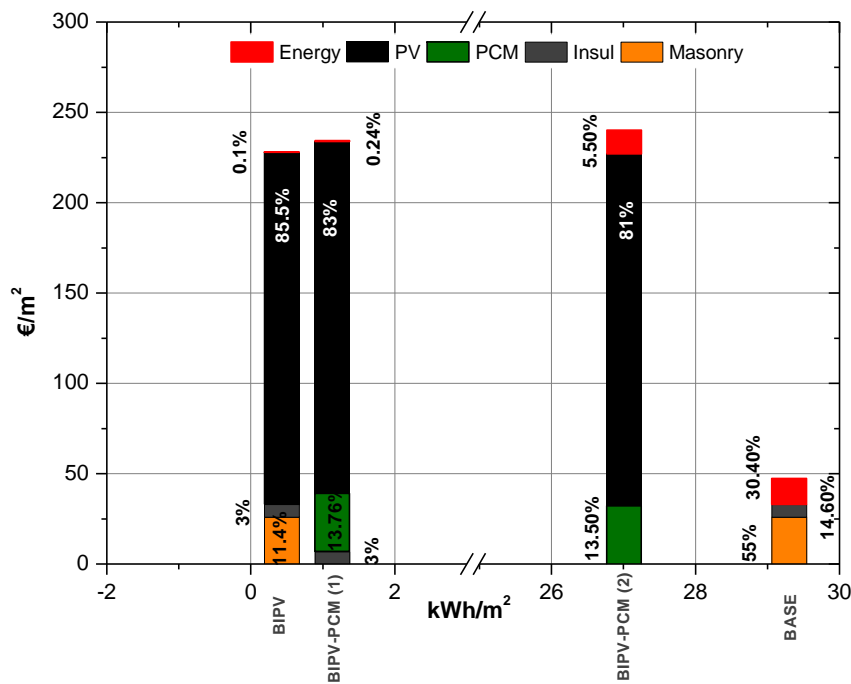

Figure 5. Costs and energy needs for square meter for each solution.

### 3. CONCLUSIONS

This paper reports the results of a preliminary study of an innovative building integrated system made of PV panels and PCM as thermal storage components. Experimental results have been presented in heating season for two different days in terms of climatic conditions. For both cases the thermal behaviour of the BIPV-PCM system presents a highest temperature difference at different hours and between the maximum and minimum values at the PV module and in the air gap and a more constant temperature at PCM gypsum board and inside room. A simplified cost analysis has been performed, where the BIPV-PCM is compared in terms of cost/energy demands with other façade solutions. The results show that even it is a most expensive solution than a traditional insulated brick wall, the BIPV-PCM system when insulated is a good solution for reducing energy demand of space/building, as it can be considered in the same time an energy generator.

## THERMAL REGULATION OF PHOTOVOLTAIC MODULES USING THERMAL ENERGY STORAGE UNITS WITH PCMS

N. Soares<sup>1,2\*</sup>, A.R. Gaspar<sup>1</sup>, F. Nunes<sup>1</sup>, V. Lourenço<sup>1</sup> and J.J. Costa<sup>1</sup>

<sup>1</sup> ADAI, LAETA, Dep. of Mechanical Engineering, University of Coimbra, Coimbra, Portugal

<sup>2</sup> ISISE, Dep. of Civil Engineering, University of Coimbra, Coimbra, Portugal

\* Correspondent author: Nelson Soares, nelson.soares@dem.uc.pt

**Keywords:** Photovoltaics (PVs), phase change materials (PCMs), PV/PCM systems, thermal energy storage (TES), thermal regulation, efficiency

**Abstract** *High operating temperatures reduce the performance of commercial polycrystalline silicon photovoltaic (PV) devices by reducing the efficiency of solar to electrical energy conversion in the PV cells. This paper presents the major developments in the construction of a real-scale experimental apparatus to evaluate the efficiency improvement of PV systems by placing a movable thermal energy storage (TES) unit filled with free-form PCMs on the panels' back. In fact, the TES units are intended to control the temperature rise in the PV cells by taking advantage of the thermal regulation potential of PCMs during phase-change. The experimental setup is placed on the flat roof of the ADAI building, located in Coimbra, Portugal. It is composed by four PV modules, separately installed and individually monitored. One of the modules is taken as reference. Different TES units (with several configurations and filled with different PCMs with diverse phase-change temperature ranges) will be added to the other PV modules. The time evolution of the temperature of the PV modules will be compared with each other to measure the effective thermal regulation effect of the TES units. A data acquisition system for current, voltage and power monitoring and recording was developed with a LabVIEW<sup>TM</sup> program interface in order to compare the efficiency of the different PV/PCM systems throughout the day. A mobile peak power and I-V-curve measurement device for PV modules will be used to measure the short circuit current ( $I_{SC}$ ) and the open circuit voltage ( $V_{OC}$ ) of the PV panels. While  $I_{SC}$  mostly depends on solar radiation, the  $V_{OC}$ -value mainly depends on the temperature of the PV cells. Therefore, the time evolution of the  $V_{OC}$ -value will be measured in order to determine the impact of PCMs in the efficiency improvement of the PV modules.*

### 1. FRAMEWORK

Phase change materials (PCMs) undergo melting/solidification at a nearly constant temperature, becoming very suitable for thermal management and TES applications. As reviewed by Soares *et al.* [1], the incorporation of PCMs in buildings can contribute to: improve thermal performance of buildings' envelope; increase indoor thermal comfort; decrease air-conditioning power needed; reduce heating and cooling demands, fossil fuels consumption and emission of ozone depleting gases; take advantage of renewables, and save money during the operational phase. Previous works have experimentally shown that the containment of PCMs in aluminium capsules with fins is a good technique to simultaneously

solve the problem of liquid-leakage and improve the heat transfer to the PCM-bulk [2,3]. These TES units can be included in the design of new TES systems such as bricks and shutters. As proposed by many authors [4-7], they can also be used for the thermal management of PV systems, which can contribute to foster new PV/PCM systems and building-integrated photovoltaics (BIPV).

Polycrystalline silicon PV devices may experience high operating temperatures, which reduces the efficiency of solar to electrical energy conversion in the PV cells. Several strategies have been proposed to mitigate overheating of PV systems and to prevent resulting power loss, including natural or forced air ventilation, hydraulic or refrigerant cooling and the use of PCMs [8,9]. Moreover, as shown in Figure 1, the actual global installed solar PV capacity makes a significant contribution to renewable energy sources, growing at faster rates than wind capacity in the last years. Therefore, the development of technologies that can be used to improve the energy performance of PV systems is seen as an active area of research.

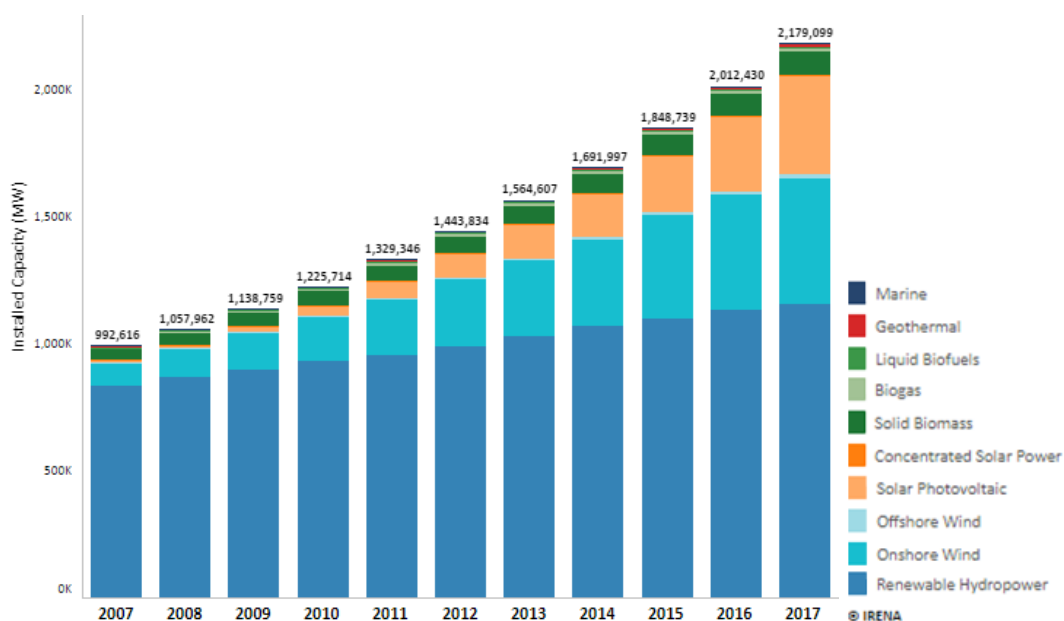

Figure 1. Worldwide renewable energy installed capacity trends [10].

This work aims to develop a real-scale experimental apparatus (*i*) to evaluate the efficiency improvement of PV/PCM systems incorporating TES units filled with free-form PCMs; (*ii*) to carry out an experimental parametric study to evaluate the influence of different configurations of the TES unit (horizontal and vertical oriented cavities) and the impact of different phase-change temperature ranges of the PCM – the PCMs RT22HC, RT25HC and RT28HC from RUBITHERM<sup>®</sup> will be used; and (*iii*) to provide reliable experimental results for numerical validation purposes.

## 2. METHODOLOGY

Figure 2 shows a sketch of the experimental setup developed (with the main equipments and instruments used) to evaluate the behaviour of a set of four Risen RSM60-6-250P PV modules under various test conditions. The PV modules are separately installed and individually monitored. One of the modules shall be taken as reference for every experiments. Different TES units made of aluminium and with several configurations will be filled with different free-form PCMs (Figure 3). The term "free-form" means that the

metallic unit is the only way of containment in order to avoid liquid leakage. The organic PCMs RT22HC, RT25HC and RT28HC from RUBITHERM<sup>®</sup> will be used. The respective melting-peak temperature of these PCMs is 22°C, 25°C and 28°C. Since these materials show a volume expansion of about 12.5% during phase-change, a small air space was left on the top of each cavity. The time evolution of the temperature of the PV modules will be compared with each other to measure the effective thermal regulation effect of the TES units. The current, voltage and power of each PV module will also be recorded during the experiments. The monitoring and data acquisition system is composed by a LabVIEW<sup>™</sup> developed program; the PicoLog<sup>®</sup> data acquisition program; seven Pico<sup>®</sup> USB TC-08 thermocouple data loggers; 126 thermocouples (K-type) properly calibrated; 12 flexible heat flux sensors; a pyranometer to measure the solar irradiance; and a Davis Instruments Vantage Pro2<sup>™</sup> weather station for measuring the weather conditions. The electrical setup has four voltage dividers and four 0.05Ω resistors for the acquisition of voltage and current data, respectively; and four DC/AC microinverter. A PVPM2540C mobile peak power and a *I-V*-curve measurement device for PV modules will be used to measure the  $I_{SC}$  and the  $V_{OC}$  values of the PV panels. Firstly, these values will be measured during a characteristic day, and prior to integrating the TES units on the panels' backs, to assure consistency in the panels. Afterwards, the time evolution of these values during a characteristic day will be measured in order to determine the impact of the TES units (thermal regulation effect) in the efficiency improvement of the PV modules.

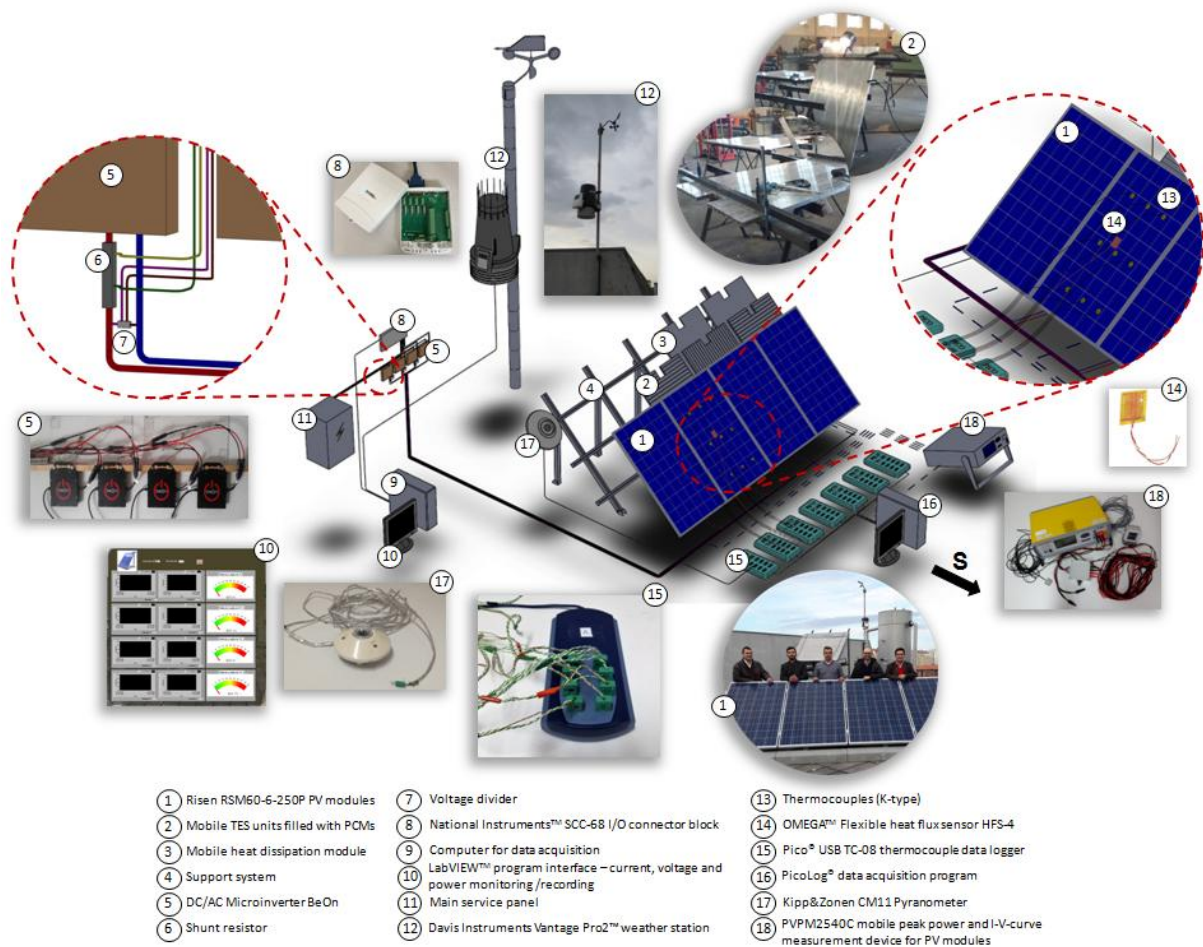

Figure 2. Sketch of the experimental setup with the main equipments/instruments used.

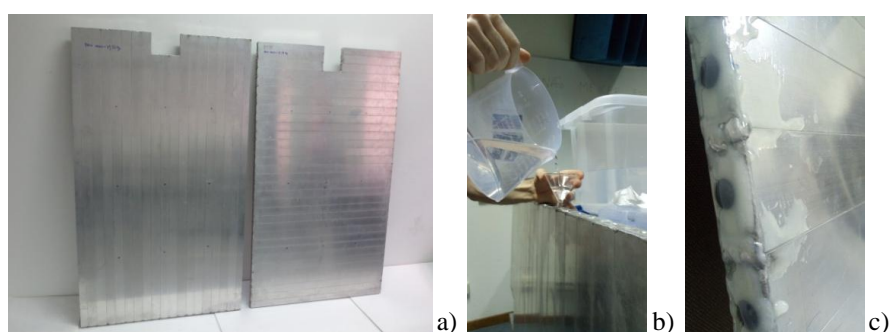

Figure 3. a) Aluminium units with vertical and horizontal cavities; b) filling the cavities with the liquid PCM; c) the cavities are sealed with rubber caps and epoxy glue to prevent leakage of liquid material.

### 3. PRELIMINARY RESULTS

The experimental apparatus is presently assembled and ready for the execution of experiments during the Summer of 2018.

#### Acknowledgements

This project is supported by FEDER funds through the COMPETE 2020 - POCI, and by Portuguese funds through FCT in the framework of the project POCI-01-0145-FEDER-016750 | PTDC/EMS-ENE/6079/2014. The authors thank João Carrilho for his help in the development of the data acquisition system. The authors also acknowledge the support of the company SunEnergy and the assistance of CTCV with their equipments.



#### REFERENCES

- [1] N. Soares, J.J. Costa, A.R. Gaspar, P. Santos, Review of passive PCM latent heat thermal energy storage systems towards buildings' energy efficiency, *Energy Build* 59 (2013) 82–103.
- [2] N. Soares, A.R. Gaspar, P. Santos, J.J. Costa, Experimental study of the heat transfer through a vertical stack of rectangular cavities filled with phase change materials, *Appl Energy* 142 (2015) 192–205.
- [3] N. Soares, A.R. Gaspar, P. Santos, J.J. Costa, Experimental evaluation of the heat transfer through small PCM-based thermal energy storage units for building applications, *Energy Build* 116 (2016) 18–34.
- [4] M.J. Huang, P.C. Eames, B. Norton, Phase change materials for limiting temperature rise in building integrated photovoltaics, *Sol Energy* 80 (2006) 1121–1130.
- [5] M.J. Huang, P.C. Eames, B. Norton, N.J. Hewitt, Natural convection in an internally finned phase change material heat sink for the thermal management of photovoltaics, *Sol Energy Mater Sol Cells* 95 (2011) 1598–1603.
- [6] A. Hasan, S.J. McCormack, M.J. Huang, J. Sarwar, B. Norton, Increased photovoltaic performance through temperature regulation by phase change materials: Materials comparison in different climates, *Sol Energy* 115 (2015) 264–276.
- [7] A. Hasan, J. Sarwar, H. Alnoman, S. Abdelbaqi, Yearly energy performance of a photovoltaic-phase change material (PV-PCM) system in hot climate, *Sol Energy* 146 (2017) 417–429.
- [8] A. Shukla, K. Kant, A. Sharma, P.H. Biwole, Cooling methodologies of photovoltaic module for enhancing electrical efficiency: A review, *Sol Energy Mater Sol Cells* 160 (2017) 275–286.
- [9] M.C. Browne, B. Norton, S.J. McCormack, Phase change materials for photovoltaic thermal management, *Renew Sustain Energy Rev* 47 (2015) 762–782.
- [10] IRENA, Trends in Renewable Energy (Installed Capacity), 2018. <http://resourceirena.irena.org/gateway/dashboard/?topic=4&subTopic=16>. [Accessed: 04/06/2018].



## DEVELOPMENTS IN THERMAL ENERGY STORAGE, THE CASE OF THE TESSE2B PROJECT

L.M.R. Coelho<sup>1,2\*</sup>, J.M. Garcia<sup>1,2</sup> and A. Rebola<sup>1,2</sup>

<sup>1</sup> Mechanical Engineering Department, Escola Superior de Tecnologia de Setúbal/IPS  
Campus do IPS, Estefanilha, 2760-761 Setúbal

<sup>2</sup> CINEA -Research Centre for Energy and Environment

\* Correspondent author: Luis Coelho, luis.coelho@estsetubal.ips.pt

**Keywords:** PCM, latent thermal storage, solar energy, geothermal heat pumps, energy buildings.

**Abstract** *This paper describes the work developments on the European Project TESSE2b. The main objective of the project is to design, develop and demonstrate a modular and low cost system of thermal storage technology based on solar collectors and efficient heat pumps for heating, cooling and hot water production (DHW) contributing to the increase the share of renewables and to the flexibility of the electricity grid. The TESSE2b project is a research project supported by the European Commission under the Horizon 2020 programme for Research and Innovation (call H2020-EeB-2015, Project No. 680555) with a duration of 48 months. The project consortium consists of ten partners from eight European countries.*

### 1. INTRODUCTION

The main objective of the TESSE2b project ([www.tesse2b.eu](http://www.tesse2b.eu) [1]) is to design, develop and demonstrate a modular and low cost system of thermal storage technology based on solar collectors and efficient heat pumps for heating, cooling and hot water production (DHW) contributing to the increase the share of renewables and to the flexibility of the electricity grid. The TESSE2b project is a research project supported by the European Commission under the Horizon 2020 programme for Research and Innovation (call H2020-EeB-2015, Project No. 680555) with a duration of 48 months. The project began in October 2015 and the duration is 48 months. The Budget is 4.311.700 euros. The project consortium consists of ten partners from eight European countries. The project is coordinated by the Polytechnic Institute of Setúbal (IPS, Prof. Luis Coelho).

This project is expected to find a solution to reduce energy consumption in homes by up to 30% for heating, cooling and DHW production, with consequent reductions in energy billing for the final consumer, with a simple period of return of the initial investment in about 8 to 9 years.

### 2. WORK DEVELOPMENT

The basis of technological development of the proposed system is related to the storage of thermal energy. This storage will be carried out at three temperature levels, for heating, for cooling and for DHW preparation. To this end, tanks are being developed which are filled by Phase Change Materials (PCM).

Suitable Phase Change Materials (PCMs) were selected for each application, using two types of PCMs, organic (paraffins) and hydrated salts, comparing their performance in each application. The tanks filled with PCMs should to be modular and easy assembled with high efficient heat exchangers (HEX) inside these tanks, immersed in PCM.

Some problems have been solved such as the incompatibility between paraffin-type PCMs and thermoplastic-based tank walls through a protective coating, the low thermal conductivity of the paraffins through the use of nanoparticles (nano-composite enhanced paraffin, NEPCM) or the use of an adequate geometry of HEX tubes and fins and a protection of the HEX metal parts from the corrosion of hydrated salts through a protective film.

Another innovation is the use of the paraffins in the boreholes heat exchangers (BHEX), mixed with the grout material, in an encapsulated form. The objective is to increase of the temperature stability of the BHEX, increasing the efficiency of the geothermal heat pump.

An intelligent control and self-learning system is also being developed in order to take full advantage of the potential of the proposed thermal system.

In the last year of the project, the TESSe2b system will be demonstrated and validated on a real scale in three houses, Austria, Cyprus and Spain, with the objective of covering three different climates.

### 3. MAIN RESULTS

The project is in the third year of progress. At this moment the pre-prototype tests are being finalized before prototypes are built and the demo sites are assembled. Between the two possible types of PCMs, paraffins and hydrated salts what is best suited to be installed in the demo sites are the paraffins. Figure 1 shows the hydraulic scheme for the demo site in Spain.

Table 1 – Preliminary results of the demo sites by numerical simulation.

Demo Site	Area (m <sup>2</sup> )	Heating Capacity (kW)	Cooling Capacity (kW)	Heating Anual needs (kWh)	Cooling Anual needs (kWh)	Heating Anual needs (kWh/m <sup>2</sup> )	Cooling Anual needs (kWh/m <sup>2</sup> )
Austria	321,1	14,39	4,67	17685,8	2784,0	55,08	8,67
Cyprus	220,7	17,03	18,56	10006,4	15431,0	45,34	69,92
Spain	137,8	12,18	4,92	8802,0	944,0	63,88	6,85

Demo Site	Solar collectores #	Hot PCM tanks	Cold PCM tanks	DHW PCM tanks	Solar Fraction Heating	Increase of solar fraction due the PCM	Solar Fraction Heating + DHW	Heating needs shifted day to night (total - solar)	Cooling needs shifted day to night
Austria	<b>10,00<sup>a)</sup></b>	<b>4</b>	*	<b>1</b>	11,8%	8,2%	20,9%	43,7%	*
Cyprus	<b>10,00<sup>b)</sup></b>	<b>3</b>	<b>3</b>	<b>1</b>	30,5%	27,2%	42,3%	44,8%	30,3%
Spain	<b>9,00<sup>b)</sup></b>	<b>4</b>	<b>2</b>	<b>1</b>	33,5%	31%	47,0%	0,0%	95,3%

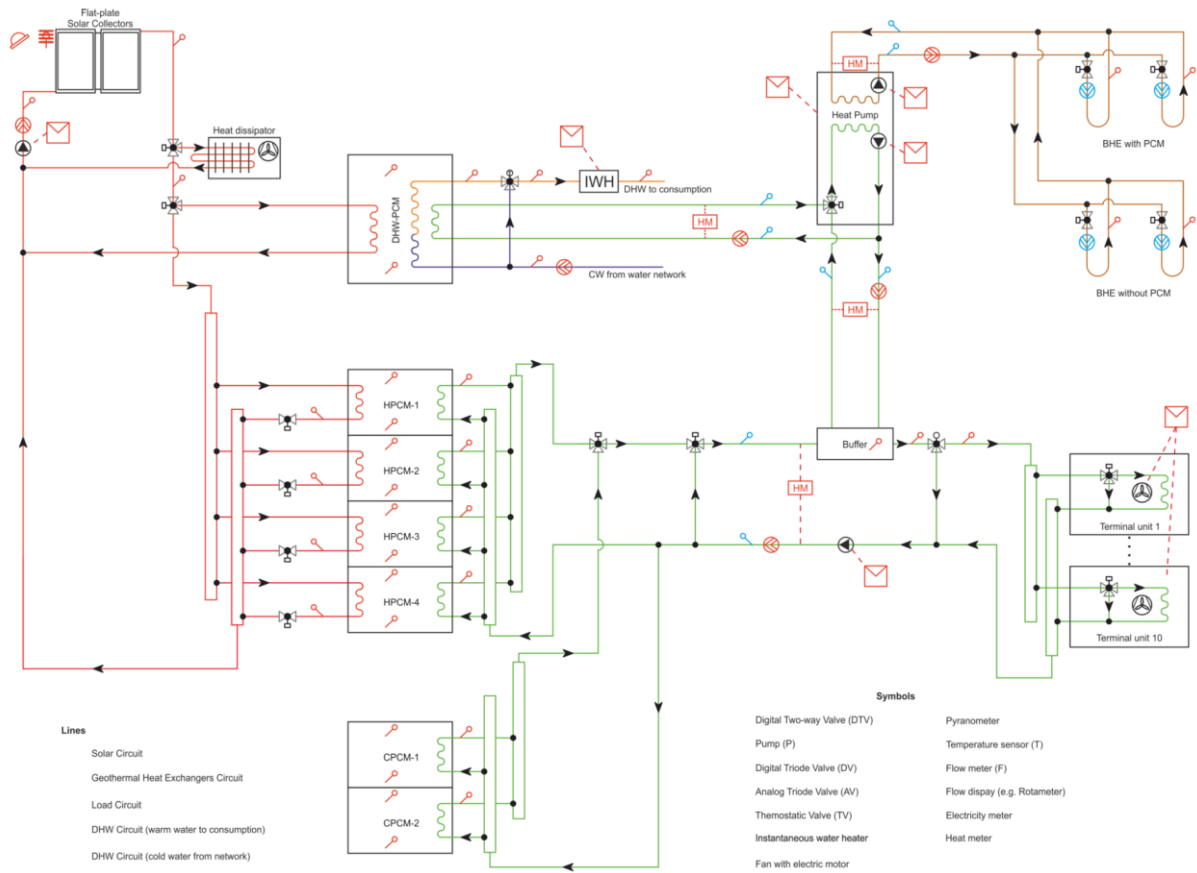

Figure 1. Hydraulic scheme for the demo site in Spain

#### 4. CONCLUSIONS

All proposed objectives of the TESSe2b project have been achieved or are in the process of being achieved. To verify the fulfilment of the final objectives it is necessary to analyse the results of the monitoring of the three demo sites that will be carried out during the last year of the project. The preliminary results obtained by numerical simulation are very promising (Table 1).

The project TESSe2b leading to this article has received funding from the European Union’s Horizon 2020 research and innovation programme under Grant Agreement No. 680555. This website reflects only the author's view and the European Commission is not responsible for any use that may be made of the information it contains.

#### REFERENCES

[1] [www.tesse2b.eu](http://www.tesse2b.eu).

## DEVELOPMENT OF PCM THERMAL ENERGY STORAGE FOR ACTIVE COOLING OF THE INDOOR SPACE

Szabolcs Varga<sup>1\*</sup>, Yosr Allouche<sup>1</sup> and Armando Oliveira<sup>1,2</sup>

<sup>1</sup> Institute of Science and Innovation in Mechanical and Industrial Engineering - INEGI, Rua Dr. Roberto Frias, Campus da FEUP, 400 4200-465, Porto

<sup>2</sup> Faculty of Engineering of the University of Porto - FEUP, Rua Dr. Roberto Frias, 4200-465, Porto

\* Correspondent author: Szabolcs Varga, szabolcs@fe.up.pt

**Keywords:** Cold storage, microencapsulated PCM, physical properties, heat transfer properties, simulation.

**Abstract** *Clever design of thermal energy storage in buildings is a critical issue for the reduction of the capital and operating costs for the owners, especially when renewable energy sources are applied. Latent heat storage (LHS) using PCMs is particularly interesting, since it can provide high storage densities with small temperature variations. This work resumes the major findings obtained with a microencapsulated phase change material (MEPCM) slurry as a low temperature thermal energy storage medium that can be applied in a solar driven air conditioning system. The MEPCM (RT15) is suspended in water with a concentration of 45% w/w and has a phase change temperature around 15°C. Both experimental and numerical studies were carried out. Thermo-physical properties were determined experimentally, including latent heats and rheological properties. It was found that enthalpy changes were >40 kJ/kg with some sub-cooling. The rheological behaviour was shear thickening, which can be explained by the relatively high concentration of the capsules. The heat transfer properties were also determined experimentally for two types of heat exchangers, empirical correlations were elaborated. Numerical work included detailed CFD simulations of a heat storage tank containing the MEPCM slurry and system modelling of a solar driven air-conditioning unit integrating storage. CFD predicted charging times within 17% of experimentally measured data. System simulations showed that for a solar air-conditioner, only a relatively small storage volume is required to obtain high solar fractions (>90%).*

### 1. INTRODUCTION

Solar-assisted space cooling is an attractive application for solar energy because of the relative coincidence between solar radiation availability and cooling demand. Thermal energy storage is essential in these applications since the energy source is intermittent and there can be a considerable time lag between supply and demand. Additionally, installed cooling capacity and related costs can be optimised by the “peak shaving” effect of a suitable storage design [1].

The use of a PCM as storage medium is very attractive, since it offers a high energy storage density over a small temperature variation, due to its high apparent specific heat during the phase change process [2]. In the case of solar-assisted air conditioning applications,

two forms of energy storage can be considered: hot storage – high temperature energy from the solar collectors is stored in a hot storage tank, and cold storage – low temperature energy from the evaporator is stored in a cold storage tank. The latter has the advantage of leading to reduced heat losses during storage and faster availability of the energy during high cooling load periods.

Major technical disadvantages of using PCMs are associated to their relatively poor heat transfer properties, such as their low thermal conductivities and high viscosities. This can be improved by a number of techniques, microencapsulation is being one of them. The present communication summarizes some of the most relevant results obtained with a MEPCM slurry including its thermo-physical characterisation and heat storage performance assessment for storing low temperature thermal energy for indoor space cooling.

## **2. APPLIED EXPERIMENTAL METHODOLOGIES**

A number of different experimental methodologies were applied during this work. Methods included Scanning Electron Microscopy under vacuum with an electron beam of 15kV for morphological characterisation. Enthalpy change measurements were carried out using DSC technique at different heating/cooling rates (0.5/1 °C/min) using the stepwise method [3]. The thermal conductivity of the slurry was determined over the storage temperature range, under isothermal conditions. Rheological behaviour was assessed using a temperature controlled rotational viscometer. Heat transfer coefficients were determined under laboratory conditions for two types of heat exchangers; a tube bundle type and a helical coil type heat exchanger.

The MEPCM was a 45% w/w aqueous dispersion of paraffin microcapsules (RT15) supplied by CIBA chemicals (UK), which a phase change temperature around 15°C. The selection of RT15 as a PCM was based on its phase change temperature range suitable for an air conditioning cold storage application.

## **3. NUMERICAL MODELLING**

A CFD model was developed for the simulation of a phase change thermal energy storage process in a 100 l cylindrical tank, horizontally placed. The heat transfer was assumed to be transient and three dimensional. The physical properties were considered to be non-linear and temperature dependent. The numerical mesh applied nearly 500k control volumes. The model was solved using FLUENT (ANSYS, USA).

A dynamic system model was also developed using the TRNSYS software. The system consists of several components including collector field, ejector chiller, PCM storage and building. Simulation were carried out for a simple office room located in Tunis, Tunisia [4]. The model can be used to find optimal storage capacity for a given solar driven cooling application.

## **4. SELECTED RESULTS**

The DSC results (Figure 1) showed that the melting started at about 13.2°C and ended at 15.8°C, whereas the crystallization onset was about at 14.6°C terminating at 12.6°C. The data indicates the existence of sub-cooling of approximately 1.2 °C. Simulated temperature distribution during the charging process is shown in Figure 2.

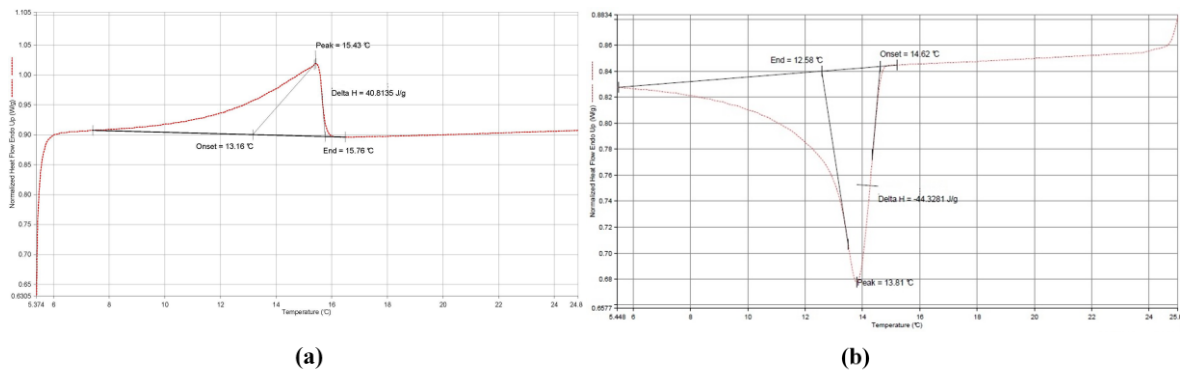

Figure 1. DSC thermographs: (a) melting process and (b) crystallization process.

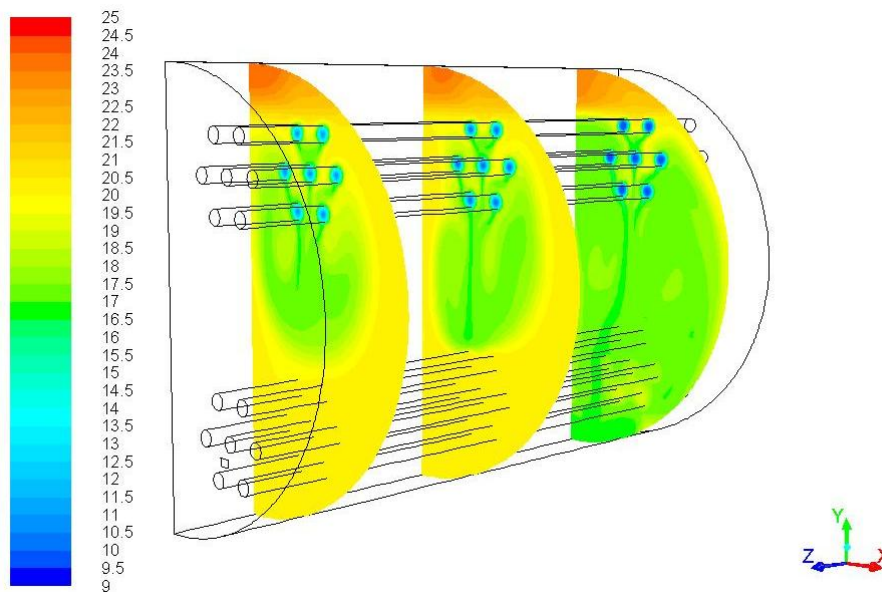

Figure 2. Temperature distribution inside the storage tank after 2h of charging.

## 5. CONCLUSIONS

High viscosity of the slurry reduces heat transfer coefficient and natural convection. Compared to water, PCM heat storage capacity was enhanced by 52%. Computer tools developed simulate accurately the heat storage process.

## REFERENCES

- [1] B.M. Diaconu, S. Varga, A.C. Oliveira (2010), Experimental assessment of heat storage properties and heat transfer characteristics of a phase change material slurry for air conditioning applications, *Appl Energy* 87(2) (2010) 620–628.
- [2] M. Silakhori, H.S.C Metselaar, T.M.I. Mahlia, H. Fauzi, S. Baradaran, M.S. Naghavi (2014), Palmitic acid/polypyrrole composites as form-stable phase change materials for thermal energy storage, *Energy Conserv Manage* 80 (2014) 491–497.
- [3] Y. Allouche, S. Varga, C. Bouden, A.C. Oliveira (2015), Experimental determination of the heat transfer and cold storage characteristics of a microencapsulated phase change material in a horizontal tank, *Energy Conserv Manage* 94 (2015) 275–285.
- [4] Y. Allouche, S. Varga, C. Bouden, A.C. Oliveira (2017), Dynamic simulation of an integrated solar-driven ejector based air conditioning system with PCM cold storage, *Appl Energy* 190 (2017) 600–611.

## MULTI-FUNCTIONAL VENTILATED BIPV FAÇADE CONCEPT COUPLED WITH PCM

Jakub Curpek<sup>1\*</sup>, Jozef Hraska<sup>1</sup> and Miroslav Cekon<sup>2</sup>

<sup>1</sup> Department of Building Construction, Faculty of Civil Engineering, Slovak University of Technology in Bratislava, Radlinskeho 11, Bratislava 813 68, Slovakia

<sup>2</sup> Research Centre AdMaS. Faculty of Civil Engineering, Brno University of Technology, Purkynova 139, Brno 612 00, Czechia

\* Correspondent author: Jakub Curpek, jakub.curpek@stuba.sk

**Keywords:** BiPV, façade, PCM, ventilation unit.

**Abstract** *The presented contribution is focused on the use of thermo-physical properties of phase change material (PCM) in a building integrated photovoltaic (BiPV) ventilated façade system. Two key functionalities of PCM integration into the façade are introduced: i. as heat exchanger inside the decentralized façade ventilation unit; ii. as thermal storage layer behind the BiPV cladding. The main objective of this motivation is to identify the influence of PCM implementation into the façade ventilation system on the overall building energy performance. Performance evaluation of this combined façade system is expected to reveal considerable energy saving potential as air supplier for the pleasant air exchange in interior spaces, as well as for decreasing operating temperature of photovoltaic (PV) cells.*

### 1. INTRODUCTION

The building energy efficiency is emphasized in developed countries around the world as one of the ways for reducing the climate change. The one of the main issues of contemporary construction industry is reduction of building energy consumption. However, building energy demand for heating and cooling is linearly depended on overall air exchange in an interior space and that is why the heat recovery system is requisite for it to achieve nearly-zero-energy status. The solar energy is being considered as one of the most promising renewable source for the integration into a building energy concept. The PV technology is potentially essential future source of clean and affordable energy and has its benefits when applying in the building sector. There are still issues that need to be carefully investigated when considering integration of PV in building facades. In this regard, PV/PCM systems [1] are already studied to improve the performance of PV, however their integration in building (BiPV/PCM) is still not adequately investigated. This can activate PV cells cooling principle behind the BiPV [2] layer in ventilated façade with air flow movement and option for ensuring of certain degree indoor air change functionality. For this purpose, a specific ventilation system can be used with combination of an innovative heat storage technology based on PCMs [3] and interconnection with façade cavity within ventilated façade system. The main principle is the using BiPV façade cavity as low-energy source with air (heat transfer medium) for integrated ventilation units.

## 2. BIPV FAÇADE SYTEM COUPLED WITH PCM VENTIALTION UNIT

BiPV systems usually reach high values of operating temperature due to insufficient cooling of PV cells during hot sunny days. Thus, ventilated façade system combined with BiPV may represent viable structure with decreasing PV operating temperature by using ventilation regime in the cavity. This produced heat can be stored in the PCM encapsulated in the aluminium container behind the BiPV layer and provide mitigating peak PV operating temperature. Additionally, the façade cavity is able to participate as a thermal buffer zone, a ventilation channel or a combination of both [4]. Seasonal configuration of this façade represents low-energy source for preheating outside air passing through the façade cavity during a winter sunny day and natural ventilation system for a summer time. Proper balance between useful and unwanted thermal energy gain should be adjusted according mutual interaction of interior vs. exterior conditions.  $U$ -value of the investigated façade is still changing over time and significantly affects the intensity and direction of the heat transfer through the exterior wall. Thermo-physical interaction between both, typical BiPV and BiPV+PCM ventilated concepts are demonstrated in Figure 1. An appropriate adjusting of air exchange between façade cavity and interior space as well as speed of airflow movement provide sensible using of solar radiation by two ways, photovoltaic and preheated air.

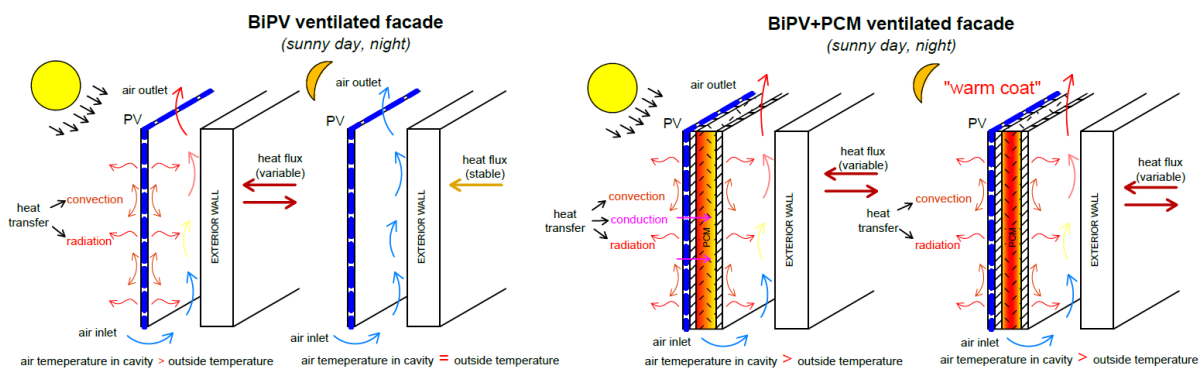

Figure 1. Schemes of the thermal behaviour of BiPV and BiPV+PCM ventilated façade.

Preheated air will directly pass through decentralized façade ventilation unit (FiV) with panels of PCM as a structure of heat exchanger for latent heat storage (Figure 2). Diurnal daily regime, warm outside air passes through façade cavity directly to the PCM-heat exchanger, where is cooled and subsequently introduced to the room. This process (PCM melting) is time-effective according latent heat thermal capacity of PCM and intensity of air flow. During nocturnal regime, cold outside air is preheated due to realising of the thermal energy stored in PCM (solidification). In the case of very high outside air temperature during entire day, it is possible to use the mixing (or solely) of secondary air from the room which bring about slower rate of melting and storage unit does not discharge so quickly. Efficiency of this system is linearly dependent on temperature of incoming air from façade cavity which value could dynamically change over time. PCM panels in the FiV heat exchanger can provide a temperature stabilization of the thermal fluctuation of incoming air [5].



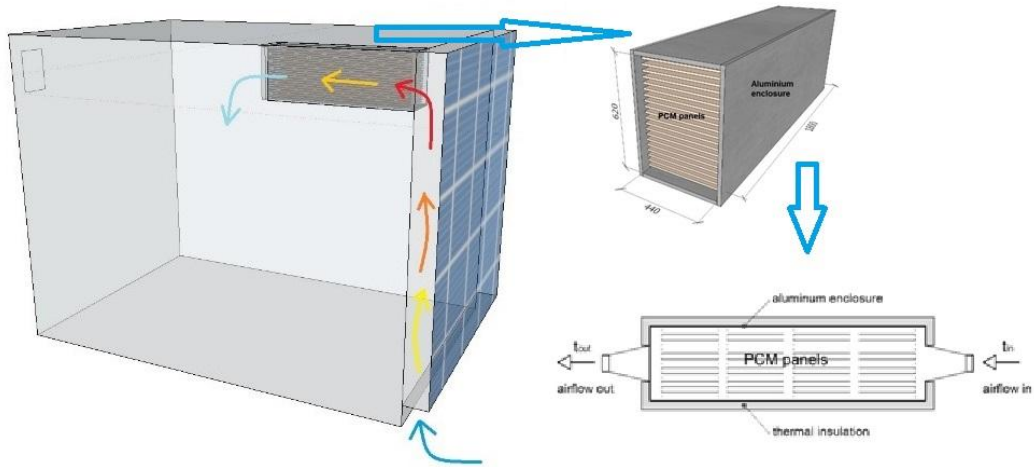

Figure 2. Concept of PCM integration into the façade ventilation unit.

### 3. EXPERIMENTAL BIPV+PCM FAÇADE TEST CELL

At first the properties of materials applied in the proposed concept are tested. This is followed by full-scale testing of one experimental BIPV+PCM prototype in real climate conditions (see Figure 3). The full-scale tests are taking place at AdMaS research centre Brno University of Technology, Czechia. The façade components are based on two materials; PV cells type is based on CIGS (copper-indium-gallium-selenide) film technology coupled with/without organic PCM type (Rubitherm RT27HC). Paraffin based PCM is employed due to its no signs of phase separation after repeated cycling through solid-liquid transitions, and a low vapour pressure [6]. In addition, it has mass based latent heats and varied phase change temperatures giving flexibility to choose proper PCMs for different latent heat thermal energy storage applications [7]. The test cell's longitudinal axis is oriented towards South-Eas to receive as much solar radiation as possible. The space inside the test cell is divided into two insulated compensating boxes (TCBs) made of particleboard. They are constructed around individual BiPV components. The TCBs separate these two testing components from each other and the internal climate of the test cell to dampen the temperature amplitudes of the internal air. Internal climate in the test cell (not in the individual test boxes) is controlled by an air-conditioning unit.



Figure 3. Experimental BiPV test cell platform.

#### 4. CONCLUSIONS

This contribution presented an essential idea of the novel BiPV+PCM façade type with its specific aspects. Development and evaluation of different technical solutions and integration of progressive materials in building facades is highly relevant issue. Direct control of velocity and direction of the air from the façade cavity according to interior requirements can reveal an interesting potential of FiV system for it to provide a certain degree of air change rate. In addition, PCMs as responsive materials that can self-adjust its internal physical properties have an ability to store passive solar and other thermal energy as latent heat within a specific temperature range. Performance prediction and simulation of PCM-enhanced façade systems are currently being relevant research challenges.

#### Acknowledgements

Authors gratefully acknowledge financial support provided by the Ministry of Education, Science, Research and Sport of the Slovak Republic under contract VEGA 1/0050/18 and by the project No. LO1408 “AdMaS UP – Advanced Materials, Structures and Technologies”, supported by Ministry of Education, Youth and Sports of the Czech Republic under the “National Sustainability Programme I”.

#### REFERENCES

- [1] M.C. Browne, B. Norton, S.J. McCormack (2015), Phase change materials for photovoltaic thermal management. *Renew Sustain Energy Rev* 47 (2015) 762–782.
- [2] B.P. Jelle (2015), Building integrated photovoltaics: a concise description of the current state of the art and possible research pathways, *Energies* 9(1) (2015) 21.
- [3] A. de Gracia, L.F. Cabeza (2015), Phase change materials and thermal energy storage for buildings, *Energ Build* 103 (2015) 414–419,
- [4] G.Y. Yun, M. McEvoy, K. Steemers (2007), Design and overall energy performance of a ventilated photovoltaic façade, *Sol Energy* 81(3) (2007) 383–394.
- [5] P. Charvat, L. Klimes, M. Ostry, Numerical and experimental investigation of a PCM-based thermal storage unit for solar air systems, *Energ Build* 68 (2014) 488–497.
- [6] S.E. Kalnæs, B.P. Jelle (2015), Phase change materials and products for building applications: A state-of-the-art review and future research opportunities, *Energ Build* 94 (2015) 150–176.
- [7] C. Alkan (2006), Enthalpy of melting and solidification of sulfonated paraffins as phase change materials for thermal energy storage, *Thermochimica Acta* 451 (2006) 126–130.

## MEASURING THE THERMAL CONDUCTIVITY OF PCMS - DOS AND DON'TS

Daniel Cederkrantz<sup>1\*</sup>

<sup>1</sup> Hot Disk AB, Sven Hultins gata 9A, 412 58 Gothenburg, Sweden

\* Correspondent author: Daniel Cederkrantz, daniel.cederkrantz@hotdisk.se

**Keywords:** Thermal conductivity, thermal effusivity, transient methods.

**Abstract** *Here the use of transient methods, or more precisely the Transient Plane Source (TPS) and Transient Hot Wire (THW) methods, is discussed in the context of testing Phase Change Materials (PCMs). Measuring the thermal conductivity of such materials requires extra care when testing close to the phase change temperature, as heat will not only be transferred through the material but will also be bound or released by the structure. Also introduced are measurements of Thermal Effusivity, as a way of expanding the scope of the TPS method and the range of samples possible to test. Best practice for thermal conductivity testing of PCMs and what traps to avoid are topics furthermore treated.*

### 1. INTRODUCTION

Measuring and analysing the thermal transport properties of PCMs is currently attracting much attention in many fields of research where such materials are utilized. The use of PCMs in e.g. building materials and consumer products like textiles is typically related to energy efficiency and/or comfort. Both these areas revolve around thermal transport properties; Thermal Conductivity, Thermal Effusivity and Specific Heat Capacity in particular.

To analyse thermal properties of solids, liquids and gels, there are several options, all with their own merits. For traditional building materials testing, Heat Flow Meters or Hot Plate setups are standard and well proven methods. However, these steady-state methods are not suitable for analysing PCMs or PCM containing matrix materials. The reason for this is related to the requirement of a temperature gradient of typically 10 to 20 °C in any sample under study. As a result, the thermal transport properties of the specimen can vary significantly throughout the sample body because of the PCM going through its phase transition in this temperature range.

As an alternative to steady-state methods, transient methods are more suitable for analysing these kinds of materials as the latter require a stable and homogeneous temperature of the sample prior to the test. There are still challenges for successful testing of PCMs with transient methods, as will be discussed below. Among the more prominent transient methods are the Transient Plane Source (TPS) and Transient Hot Wire (THW) techniques, each with its individual strengths. However, the more general and versatile method is the TPS approach. It is important to keep in mind that all transient methods require heat to be added to the system during testing. How the heat diffuses from the probe is then evaluated and the relevant thermal properties are calculated. However, in a PCM not only is the heat transferred, it can also be stored or released in the affiliated phase change process.

## 2. THE TRANSIENT PLANE SOURCE TECHNIQUE

The TPS or Hot Disc method is a versatile transient technique for testing the thermal transport properties of a wide range of materials [1,2]. It will measure thermal conductivity, diffusivity and effusivity, as well as specific heat of isotropic samples. If samples are anisotropic, the method can be used to analyse the conductivity in the plane and through the plane of the sample, in a single measurement. The TPS method utilizes Hot Disc probes, which consist of a double spiral sensing element, typically made of nickel, supported by a thin but durable polymer substrate. Hot Disc probes typically have a diameter from ca 1 mm up to 60 mm. The size of the sensors is governed by the size and properties of the sample in question. A great benefit of the method is that it is absolute and requires no calibration, nor testing against standard materials or any thermal contact agent to function.

When testing PCMs, it is advised to avoid using overly large sensors. This recommendation is linked to the fact that the last possible amount of heat should be allowed to enter the system during testing. Smaller sensors require less power, thus conveying less heat to the sample. Another benefit of a smaller probe is that the measurement time is reduced, which further limits the total amount of energy released and allows less time for any phase changes to transpire during the test. The smallest viable sensor size is decided by the structure of the sample. If the sample is homogeneous, *e.g.* a polymer or wax, a 2 mm radius probe can be employed with good result. If the sample is heterogeneous, *e.g.* a concrete sample with added PCMs and aggregates, a probe with large enough radius to cover an area representative for the entire sample is required. A guideline is that the probe radius should be at least 10 times the average aggregate radius. Potentially a smaller sensor can be used, if testing is repeated at several locations across the sample surface and an average is calculated, representing the entire sample.

For a normal TPS test, it is advised to use a heating power large enough to increase the temperature of the probe with 2 to 5 K. When testing PCMs, however, it is suggested that one use as small heating power as possible, to approach the phase change temperature, without incurring the actual phase change, as this will affect the results. A lower than normal heating power will result in a higher noise level and thus less precision. One way of countering this is to perform repeated tests at a given temperature and subsequently calculating an average result, a procedure which can yield good accuracy.

It is crucial to realize that it is not fruitful to perform tests in the actual phase change temperature range, as during this event the heat is not only transported through the material but also bound or released by the phase transition. This will affect the measurement results, generating apparent rather than real values as the calculation assumes all heat to be transferred through the system. This can often be seen as an increasing thermal conductivity as the transition temperature is approached, and then suddenly as an underestimated conductivity once the transition temperature has been passed. Instead, adjusting the parameters to obtain unaffected data as close as possible below and above the phase change temperature is recommended. A standard interpolation of the conductivity values between these two points can then be used to estimate the pure thermal conductivity in the phase change temperature range.

## 3. TRANSIENT HOT WIRE

The Transient Hot Wire (THW) method [3] is at once a less complex and less versatile method, as compared to the TPS method. It still has certain benefits when testing PCMs,

the major asset being the simplicity of the method. However, the THW method requires calibration, as opposed to the TPS method. The calibration involves a basic offset calibration, and the reference sample is typically DI water. As a result, the thermal conductivity range is limited.

Basic THW testing is typically restrained to liquids, pastes and soft materials, as the sample must be in perfect contact with the heating wire. Thus, a THW device is most suitable for testing pure PCMs and not complex PCM containing composites. Satisfactory results can be acquired for most materials going through a liquid phase in the temperature range of the THW device at hand.

The method by default utilizes very short measurement times and the heating energy is also limited, making it easier to approach the phase change temperature without triggering the actual transition, making testing straight-forward, intuitive and easily repeated.

#### **4. THERMAL EFFUSIVITY**

Thermal effusivity is directly linked to thermal conductivity and specific heat. It is a measure of how a material transfers heat to its surroundings and is closely associated with how a material feels to the touch. As such, it has certain merits when comparing different PCMs, and it can readily be measured with a TPS device. As a matter of fact, it is sometimes easier to measure this property than the thermal conductivity. This is especially true for small samples or samples which demand a large sensor due to inhomogeneities, yet which still require short measurement times due to *e.g.* limited thickness. Furthermore, thermal effusivity can be used to investigate a material's development as exposed to heat over time, employing measurements with increasing test times performed in a series on the same sample. By doing so a comparative picture can be drawn for a specific sample, which in turn can easily be compared to that of another material, tested under the same scheme. Utilizing this knowledge can expand the range of samples which can be tested with a TPS system, and potentially opens new avenues for testing materials [4].

#### **5. CONCLUSIONS**

Certain transient methods, *i.e.* TPS and TWH, can be utilized to successfully test thermal transport properties of PCMs, even close to the relevant phase change temperature. As no temperature gradient should be present in a sample analysed with these methods, testing at well-defined temperatures is made possible. The methods discussed here still require that heat be added to the system, but this can be kept to a minimum to avoid triggering a phase change. This in turn would create artefacts in the measurement results. Also, by minimizing test times, the above issue can be further limited. The TPS method allows great flexibility as heating power, measurement time and sensor size all are parameters possible to optimize for the specimen at hand. The THW is less flexible but will by default work with lesser amounts of heat and short measurement times, making it an easy-to-use option for testing pure PCMs which are either very soft or go through a liquid state. Thermal effusivity has finally been introduced as a measure to test complex samples or to compare samples in a novel way.

#### **REFERENCES**

- [1] S.E. Gustafsson (1991), Transient plane source techniques for thermal conductivity and thermal diffusivity measurements of solid materials, *Rev. Sci. Instrum* 62 (1991) 797–804.
- [2] ISO 22007-2:2015 Plastics – Determination of thermal conductivity and thermal diffusivity – Part

- 2: Transient plane heat source (Hot Disc) method.
- [3] ASTM D7896 – 14 – Standard Test Method for Thermal Conductivity, Thermal Diffusivity and Volumetric Heat Capacity of Engine Coolants and Related Fluids by Transient Hot Wire Liquid Thermal Conductivity Method.
- [4] D. Hume, C. Vail, A. Sizov, D. Cederkrantz, Y. Ma, B. Mihiretie, M.K. Gustavsson, S.E. Gustafsson (2017), Thermal Effusivity testing with the Hot Disk Thermal Constants Analyser, in: International Thermal Conductivity Conference 2017, Logan, Utah, USA, 15–18, May, 2017.

## PROPERTIES OF CEMENT MORTARS WITH PHASE CHANGE MATERIALS (PCM'S)

José B. Aguiar<sup>1\*</sup> and Sandra Cunha<sup>1</sup>

<sup>1</sup> Centre for Territory, Environment and Construction, Department of Civil Engineering, University of Minho, Campus de Azurém, 4800-058 Guimarães, Portugal

\* Correspondent author: José B. Aguiar, Aguiar@civil.uminho.pt

**Keywords:** Mortars, cement, microencapsulated Phase Change Materials, non-encapsulated Phase Change Materials.

**Abstract** *The high energetic consumption is one of the biggest concerns of modern society. The incorporation of phase change materials (PCM) in construction materials allows regulates the temperature inside the buildings. During the last years several studies of construction materials with incorporation of encapsulated PCM have been published. However, the utilization of non-encapsulated PCM is one of the main gaps. In this study several properties of mortars with incorporation of microencapsulated and non-encapsulated PCM are presented.*

### 1. INTRODUCTION

The energy efficiency of buildings is now one of the main objectives of regional, national and international energy management. Every year the energy powered by the sun that reaches the entire land surface is about 10000 times higher than the actual energy consumption per year worldwide [1]. Taking into account that the European building sector is responsible for high energetic consumptions, it is important to find a way to take advantage of the solar energy.

It is known that the largest part of the energy consumption in construction industry, specifically in residential sector is associated with the needs for heating and cooling. This problem is related with the excessive use of energy from non-renewable sources, which cause serious environmental impacts. Therefore, it becomes imperative to obtain a constructive solution that minimizes these consumptions, improving the energetic efficiency of buildings without damaging the environment. The incorporation PCM in mortars appears as a possible solution in an attempt to solve, or at least minimize, the massive energetic consumption in buildings.

The PCM can be integrated into construction materials using diverse techniques: immersion, direct incorporation, shape stabilization and encapsulation (microencapsulation and macroencapsulation). During this study it was evaluated several properties of cement mortars with microencapsulated and direct incorporation of non-encapsulated PCM.

### 2. MATERIALS

The microencapsulated PCM used is composed of a wall in melamine-formaldehyde and a core in paraffin, with temperature transition of about 22.5 °C, enthalpy of 147.9 kJ/kg and a density of 880 kg/m<sup>3</sup>. The process of fabrication is polycondensation by addition. This material exhibits a transition temperature of 24 °C in the heating cycle and 21°C in the

cooling cycle.

The non-encapsulated PCM used is composed by paraffin with temperature transition between 20 and 23°C, enthalpy of 200 kJ/kg, density in solid state of 760 kg/m<sup>3</sup> and in liquid state of 700 kg/m<sup>3</sup>.

### **3. RESULTS AND DISCUSSION**

#### **3.1. Cement mortars with microencapsulated PCM**

Regarding to the workability tests it was possible to verify an increase in the quantity of water with the incorporation of PCM microcapsules. This can be explained by the reduced particle dimension of the used PCM [2].

Scanning electron microscope observations were performed in order to evaluate the existence of possible incompatibilities between different materials present in mortars. It was possible to observe a good connection between the different materials (PCM, fibers, aggregate and binder) evidenced by the absence of cracks in the microstructure of the mortars developed. It can be seen that the PCM microcapsules present a good and homogeneous distribution in the matrix. The PCM showed a good integrity, without signs of rupture or damages, demonstrating that the microcapsules can adequately resist to the process of mortar mixing, application and curing. The microporosity increased with the incorporation of PCM. Higher dimensions micropores were observed in the mortars with incorporation of PCM compared with the reference mortar. The presence of higher microporosity can be explained by the higher water content of the mortars doped with PCM [2].

The water absorption by capillarity coefficient is related with the velocity of water absorption and the dimensions of pores. Thus, higher coefficients reveal the existence of a larger amount of pores with small size and consequently an increase in water absorption velocity. It was possible to verify that the incorporation of PCM caused a decrease in the capillary absorption coefficient in the cement based mortars.

Regarding to the mechanical behaviour it was observed that the incorporation of PCM caused a decrease in flexural and compressive strengths. This behaviour is related to the presence of a greater amount of water in the formulation of the mortars.

In the thermal behaviour it was possible to observe that the incorporation of PCM microcapsules leads to a decrease of the maximum temperatures and an increase in the minimum temperatures. It was also possible to observe that the mortars with PCM do not present temperatures higher than the maximum comfort temperature (25°C) in the spring season and temperatures lower than the minimum comfort temperature (20°C) in the autumn season. Thus, it will not be necessary the use of cooling equipment during the spring season and heating equipment during the autumn season. These results allow to conclude that the utilization of PCM in interior coating mortars can reduce the energetic consumptions [2].

#### **3.2. Cement mortars with direct incorporation of non-encapsulated PCM**

Regarding the workability results, it was possible to observe a decrease in the water content with the incorporation of non-encapsulated PCM. However, the liquid material/binder ratio remains constant. This behaviour can be justified by the utilization of liquid PCM, which in part can operate as agent for the formation of a homogeneous mortar, replacing part of the water [3].

The microscope observations showed that the incorporation of non-encapsulated PCM leads to a decrease in the pores quantity and a decrease in its size. This behaviour can be



explained by the decrease of the water content present in the mortars with PCM incorporation. It was also possible to identify that the mortars without PCM addition present a more crystalline microstructure, resulting from the increase cement hydration, when compared to the mortars with PCM incorporation. This behaviour can be justified by the porosity decrease, since there is less space in the PCM mortars microstructure to the cement hydration reactions [3].

Regarding the water absorption by capillarity it was observed that the incorporation of non-encapsulated PCM leads to a decrease in the capillary absorption coefficient, due to the partial or total occupation of the mortar pores by the PCM. Finally, according to flexural and compressive strengths, it can be concluded that the incorporation of non-encapsulated PCM did not cause significant changes in the mortars mechanical behaviour. This situation can be explained by the contained PCM inside the pores, not weakening the mechanical strength. On the other hand, it was verified a liquid material/binder ratio similar for all compositions [3].

#### 4. CONCLUSIONS

The incorporation of microencapsulated PCM and non-encapsulated PCM cause some changes to the properties of cement mortars in fresh and hardened states. However, the utilization of PCM for interior coating mortars can reduce the energetic consumptions, reducing the energy demand, the fossil fuel depletion and the environmental impact associated with the heating and cooling systems.

#### REFERENCES

- [1] G. Blengini, T. Carlo (2010), The changing role of life cycle phases, subsystems and materials in the LCA of low energy buildings, *Energ Build* 42 (2010) 869–880.
- [2] S. Cunha, J. Aguiar, A. Tadeu (2016), Thermal performance and cost analysis of mortars made with PCM and different binders, *Constr Build Mater* 122 (2016) 637–648.
- [3] S. Cunha, M. Lima, J. Aguiar (2016), Influence of adding phase change materials on the physical and mechanical properties of cement mortars, *Constr Build Mater* 127 (2016) 1–10.

## PHASE CHANGE MATERIALS FOR IMPROVING THE THERMAL PERFORMANCE OF LSF CONSTRUCTION

Paulo Santos<sup>1\*</sup>, Margarida Gonçalves<sup>1</sup>, Cláudio Martins<sup>1</sup>,  
Nelson Soares<sup>1,2</sup> and José J. Costa<sup>2</sup>

<sup>1</sup> ISISE, Department of Civil Engineering, University of Coimbra, Pólo II, Rua Luís Reis Santos, 3030-788 Coimbra, Portugal

<sup>2</sup> ADAI, LAETA, Department of Mechanical Engineering, University of Coimbra, Pólo II, Rua Luís Reis Santos, 3030-788 Coimbra, Portugal

\* Correspondent author: Paulo Santos, pfsantos@dec.uc.pt

**Keywords:** PCMs, LSF construction, buildings, thermal performance, PCMs4Buildings

**Abstract** *Energy is nowadays a prime concern of our society and the buildings' sector is an important player regarding energy consumption. Energy efficiency and the use of renewable energy sources are two strategies implemented by European Directives to address the energy performance of buildings. The research project PCMs4Buildings – Systems with PCM-filled rectangular cavities for the storage of solar thermal energy for buildings – was funded by FCT and by FEDER/COMPETE2020/POCI. The main goal of this research project is the development of systems with PCM-filled rectangular cavities for the storage of solar thermal energy in order to enhance the energy performance of buildings. Given their reduced thermal mass, lightweight steel framed (LSF) buildings are very suitable for the use of phase change materials (PCMs). Therefore, the PCMs4Buildings project mainly focuses on LSF construction, namely in the scope of Task 4 – “Tests in the Guarded Hot Box Apparatus” and of Task 5 – “Definition of full-scale prototypes”. In this communication it will be described the research activities related with Task 4 and the obtained results, as well as the future work.*

### 1. INTRODUCTION

The aim to increase energy efficiency of buildings and to make use of renewable energy sources, including passive technologies (*e.g.* making use of solar heat gains), has fostered the researchers to study, develop and implement several strategies to achieve this goal. Several research projects have been funded with these purposes. *PCMs4Buildings* [1] is a research project funded by the Portuguese foundation for science and technology (FCT) and by European funds (FEDER/COMPETE2020/POCI). The main goal of this research project is to improve the energy efficiency of buildings by making use of solar thermal energy stored in rectangular cavities filled with PCMs. Given its advantages described in refs. [2,3], and due to its light-weightness and consequent reduced thermal mass, LSF buildings are very appropriate for the use of PCMs. Thus, the *PCMs4Buildings* project mainly focuses on LSF construction regarding real-scale research. The main goal of this communication is to present the research activities related with Task 4 – “*Tests in the Guarded Hot Box*”, describing the tests already performed and the achieved results. After this brief introduction, the main tasks of the *PCMs4Buildings* project are listed. Then, the (guarded) hot box apparatus is

described and the experimental tests already accomplished are described and the obtained results presented. Next, several 2D and 3D numerical simulations are presented and the obtained results commented. Afterwards, a comparison between the experimental and the numerical results is made. To conclude this communication, some final remarks and future works are presented.

## 2. PCMS4BUILDINGS RESEARCH PROJECT

The research plan of the project *PCMs4Buildings* is composed by six main tasks [1], namely: (1) thermophysical characterization of PCMs; (2) numerical modelling and CFD evaluation; (3) tests in the small-scale experimental setup; (4) tests in the guarded hot box apparatus; (5) definition of full-scale prototypes; (6) technical seminar and workshop. This work will be mainly focussed on Task 4 related research activities and obtained results.

## 3. (GUARDED) HOT BOX APPARATUS

The guarded hot box apparatus was designed and assembled at ISISE-DEC/FCTUC during a PhD work by Cláudio Martins, taking into account the prescriptions provided by EN ISO 8990 [4]. It allows measuring the thermal transmittance ( $U$ -value) of heterogeneous walls at real-scale test-specimens, up to  $3.6W \times 2.7H \times 0.4T$  (m), as illustrated in Figure 1. Unfortunately, several problems have arisen during the calibration process, with consequent delays in the experimental campaign and meanwhile the equipment has been used as climatic chambers: hot and cold boxes, instead of a guarded hot box. Therefore, as an alternative to the metering box, the thermal performance of the LSF walls is measured locally using heat flux sensors and thermocouples. Given the above mentioned delays it was not possible yet to measure the thermal performance of LSF walls with PCMs.

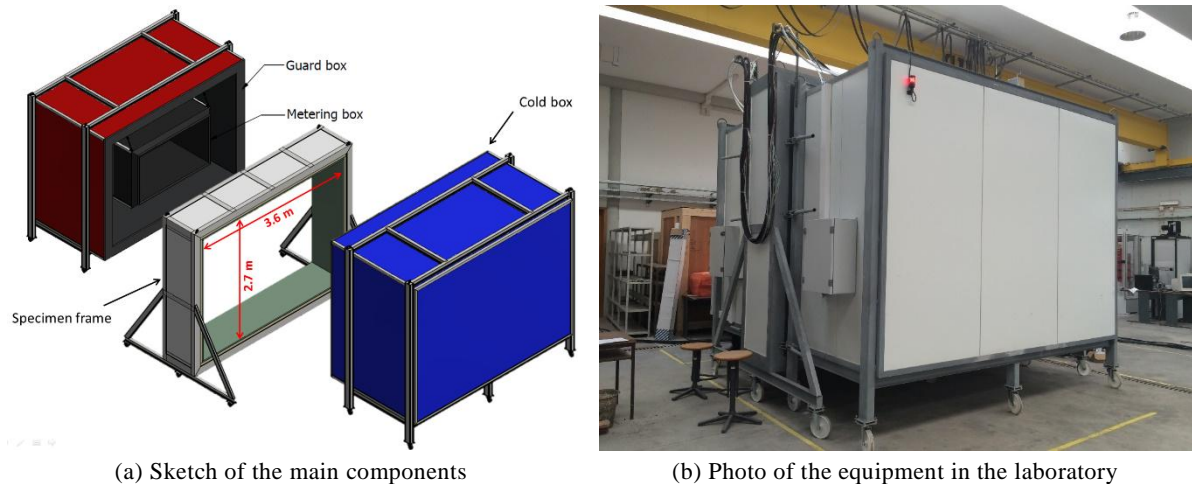

Figure 1. (Guarded) hot box apparatus.

## 4. EXPERIMENTAL TESTS

The test procedures to measure the thermal performance of the LSF walls followed the prescriptions provided by several international standards, namely ISO 9869:1994 [5], ASTM C 1155-95 [6] and ASTM C 1046-95 [7]. Until now, four different wall configurations were tested, as illustrated in Figure 2, and three tests were performed for each wall configuration. The 10 cm-thick XPS wall panel was tested to verify the test

procedures and evaluate its accuracy, since the thermal conductivity of the XPS material is known ( $0.036 \text{ W}/(\text{m}\cdot^\circ\text{C})$ ). The average difference between the measured thermal conductivity and the value provided by the manufacturer was +5%, which is acceptable given the sensors precision and other uncertainties.

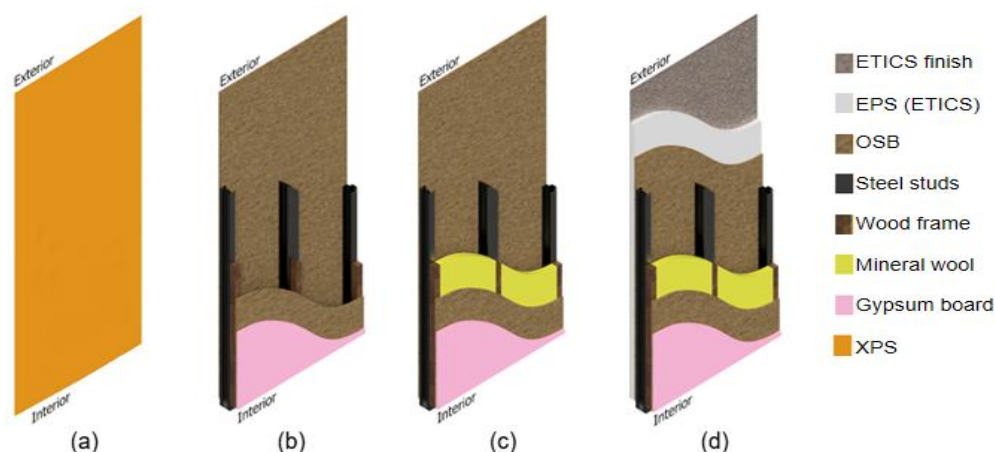

Figure 2. Tested walls: (a) homogeneous XPS panel; and heterogeneous LSF walls: (b) without thermal insulation; (c) with mineral wool (MW) in the air-cavity; (d) with MW in the air-cavity and ETICS.

Table 1 presents the thermal transmittance values obtained for the LSF walls using the data recorded during the experimental tests. The wood bars allowed to reduce the thermal bridge effect originated by the steel studs. The overall weighted  $U$ -value for the LSF wall without thermal insulation was  $1.480 \text{ W}/(\text{m}^2\cdot^\circ\text{C})$ . The addition of 5 cm MW to the air-cavity allowed to significantly reduce the thermal transmittance of the wall (-52%). Given the thermal insulation continuity of the ETICS, the steel studs thermal bridge effect was reduced, resulting in  $U$ -values between and near the steel profiles closer to each other. The obtained overall  $U$ -value of this 3<sup>rd</sup> wall was  $0.324 \text{ W}/(\text{m}^2\cdot^\circ\text{C})$ .

Table 1.  $U$ -values obtained for the LSF walls based on experimental data.

Wall typology	Thermal transmittance, $U$ [ $\text{W}/(\text{m}^2\cdot^\circ\text{C})$ ]			
	Between steel studs 0	Near steel studs 1	Near steel studs 2	Overall weighted value
1-Without thermal insulation	1.568	1.041	1.203	<b>1.480</b>
2-With Mineral Wool (MW) in air-cavity	0.658	0.788	1.128	<b>0.711</b>
3-With MW in air-cavity and ETICS	0.279	0.363	0.470	<b>0.324</b>

## 5. NUMERICAL SIMULATIONS

The three LSF walls were modelled in a 2D (THERM) and a 3D (ANSYS) simulation software, based on the finite elements method. To minimize the computer resources needed for the 3D simulations, only a representative part of the total tested wall modules was modelled ( $1.20\text{W} \times 1.25\text{H}$  m). The boundary conditions for the wall hot and cold surfaces (ambient temperatures and surface thermal resistances) were obtained from the experimental tests (average values were used). Moreover, several adiabatic surfaces were used, including the border boundaries of the calculation domain in the 3D model. The values of the material properties (*e.g.* thermal conductivity) used in the simulations were provided by the manufacturers or taken from databases (standard values).

Figure 3 displays the temperature distributions predicted by the 2D (THERM) and 3D (ANSYS) simulations along a horizontal cross-section of the LSF walls. A very good agreement is observed between the two numerical approaches. Moreover, these plots allow to confirm the steel studs thermal bridge mitigation effect provided by the wood bars (LSF wall n.1) and by the ETICS (LSF wall n.3).

## 6. COMPARISON BETWEEN EXPERIMENTAL AND NUMERICAL RESULTS

Table 2 presents the  $U$ -values provided by the measured data from the experiments (Exp.) and by the 3D (ANSYS) and 2D (THERM) numerical predictions. The differences between the predictions and the measurements are quite small ([0.018; 0.130] W/(m<sup>2</sup>·°C) or [4.8; 18.3] %). These errors could be due to sensors imprecision, inaccuracy in the sensors location, workmanship imperfections, joints between panels that were not modelled, neglected convection effects inside the air-cavity, etc. These differences are greater for the LSF wall n.2 with 5 cm MW in the air-cavity. This can be due to possible workmanship imperfections during the colocation of the MW in the air-cavity. For this simple configuration of LSF walls (with only vertical steel studs in the metering area) the accuracy of 2D and 3D models is very similar.

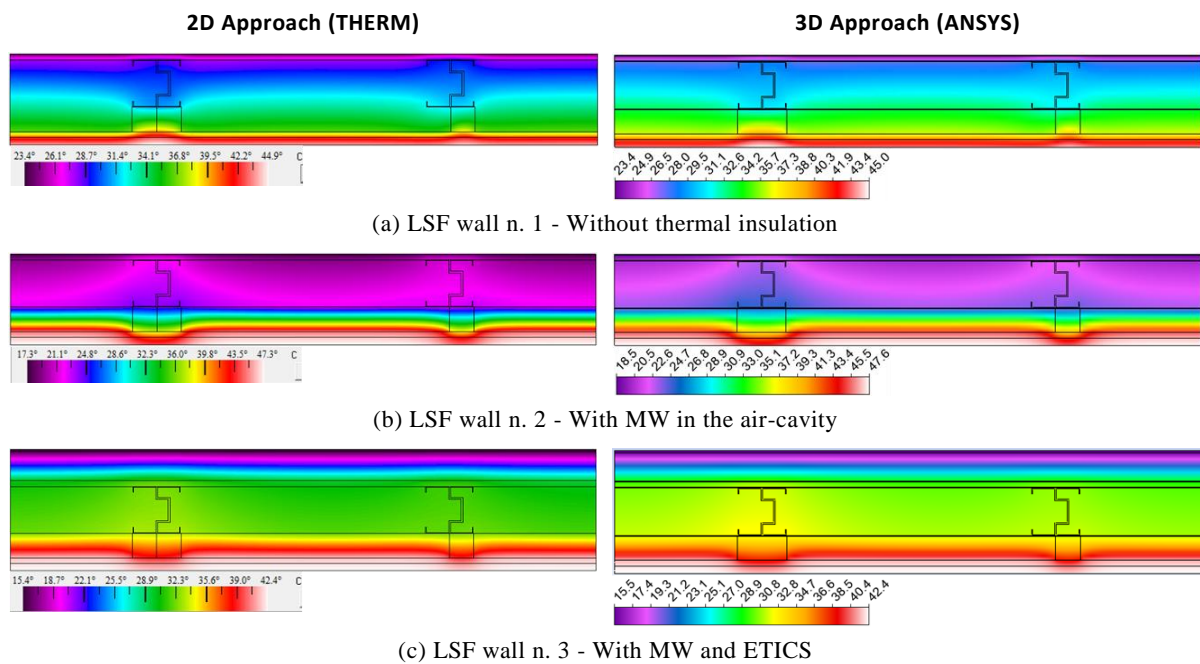

Figure 3. Cross-section temperatures predicted by 2D and 3D numerical simulations.

Table 2. Experimental and numerical  $U$ -values obtained for the LSF walls.

	Wall n.1 - Without Thermal Insulation			Wall n.2 - With Mineral Wool (MW)			Wall n.3 - With MW and ETICS		
	Exp.	ANSYS	THERM	Exp.	ANSYS	THERM	Exp.	ANSYS	THERM
$U$ -value [W/m <sup>2</sup> /°C]	1.480	1.409	1.399	0.711	0.598	0.581	0.324	0.346	0.306
Absol. Diff.	---	-0.071	-0.081	---	-0.113	-0.130	---	+0.022	-0.018
Perc. Diff.	---	-4.8%	-5.5%	---	-15.9%	-18.3%	---	+6.8%	-5.6%

## 7. FINAL REMARKS AND FUTURE WORK

In this short paper, the research activities related with Task 4 of the project *PCMs4Buildings* were presented, as well as the obtained preliminary results. As ongoing work, some tests will be performed with the same LSF wall module adding a layer of PCM containing material. Other LSF walls prototypes, with a more complex structure, will also be tested.

### Acknowledgements

This project is supported by FEDER funds through the COMPETE 2020 - POCI, and by Portuguese funds through FCT in the framework of the project POCI-01-0145-FEDER-016750 | PTDC/EMS-ENE/6079/2014.



### REFERENCES

- [1] N. Soares, A.R. Gaspar, P. Santos, A.G. Lopes, L. Durães, P.N. Simões, J.J. Costa (2016), Kick-off presentation of the project "PCMs4Buildings" - Systems with PCM-filled rectangular cavities for the storage of solar thermal energy for buildings, *CINCOS'16 – International Congress of Innovation on Sustainable Construction*, (ISBN: 978-989-95978-4-6) pp.235-247, Lisboa, Portugal, 3-4 de November, 2016.
- [2] P. Santos, L. Simões da Silva, V. Ungureanu, *Energy Efficiency of Light-weight Steel-framed Building*". European Convention for Constructional Steelwork (ECCS), Technical Committee 14 - Sustainability & Eco-Efficiency of Steel Construction, ISBN 978-92-9147-105-8, N. 129, 1<sup>st</sup> edition, (2012).
- [3] N. Soares, P. Santos, H. Gervásio, J.J. Costa, L. Simões da Silva (2017), Energy efficiency and thermal performance of lightweight steel-framed (LSF) construction: a review, *Renew Sustain Energy Rev* 78 (2017) 194-209 (ISSN: 1364-0321).
- [4] EN ISO 8990:1996. Thermal insulation - Determination of steady-state thermal transmission properties - Calibrated and guarded hot box. European Committee for Standardization, Brussels, Belgium, 1996.
- [5] ISO 9869:1994. Thermal insulation – building elements – In-situ measurement of thermal resistance and thermal transmittance. International Organization for Standardization, Geneva, Switzerland, 1994.
- [6] ASTM C 1155-95. Standard practice for determining thermal resistance of building envelope components from the in-situ data. American Society for Testing and Materials, USA, Pennsylvania, 1995.
- [7] ASTM C 1046-95. Standard practice for in-situ measurement of heat flux and temperature on building envelope components. American Society for Testing and Materials, USA, Pennsylvania, 1995.

## THERMAL PERFORMANCE OF A WINDOW SHUTTER WITH PHASE CHANGE MATERIALS

Tiago Silva<sup>1\*</sup>, Romeu Vicente<sup>2</sup>, Maria Fernanda Rodrigues<sup>2</sup> and Cláudia Amaral<sup>1,2</sup>

<sup>1</sup>CICECO, Aveiro Institute of Materials, Civil Engineering Department, University of Aveiro,  
Campus Universitário de Santiago, 3810-193 Aveiro, Portugal

<sup>2</sup>RISCO, Civil Engineering Department, University of Aveiro, Campus Universitário de Santiago,  
3810-193 Aveiro, Portugal

\* Correspondent author: Tiago Silva, Tel.: +351 234 370 845, Fax: +351 234 370 094,  
email: tiagomsilva@ua.pt

**Keywords:** Energy performance, phase change material (PCM), thermal energy storage (TES) system, window shutter.

**Abstract** *The building sector is the largest final end-use consumer of energy in the European Union. The large energy consumption of the building sector is mainly resourcing to active systems for cooling and heating of indoor spaces. Presently, the external envelopes of offices and commercial buildings are systematically composed by large glazed areas, which lead to substantial heat losses through these zones. Thermal Energy Storage (TES) systems, using phase change materials (PCM) in buildings, are widely investigated technologies and a fast developing research area. The use of phase change materials (PCMs) is presently an advanced solution to improve the energy performance of building components, namely the glazing and window shutter protections solutions. The present work evaluates the thermal performance of a thermal energy system that contains PCMs. The testing apparatus is composed by two side-by-side compartments that have two similar windows shutters, one containing PCMs and the other considered as a reference solution, without PCMs. The internal compartments were submitted to similar weather conditions during the summer and winter season. The results reveal the PCM potential for the thermal regulation of indoor spaces as well as improving the energy efficiency of indoor building spaces.*

### 1. INTRODUCTION

Currently, the environmental concerns and the energy efficiency are two widely compatible main research topics. According with the International Energy Agency (IEA) the buildings sector in the European Union is currently the single largest final end-use consumer of energy [1]. The energy consumption of this sector is 470 Mtoe (million tonnes of oil equivalent) of 1194 Mtoe which represents about 40% of the total energy consumption [1]. Not considering the emissions associated with the electricity use in the building sector, the CO<sub>2</sub> emissions represent 12% of the total CO<sub>2</sub> emissions produced in 2011 [1].

According with the IEA [1] the global primary energy consumption will rise in average at an annual rate of 1.2% through 2035 and as the building sector is the largest energy consumer, it is imperative to improve the energy efficiency of the building sector and decrease its energy consumption [1,2]. By 2035 it is expected that the energy consumption in

the building sector increases 29%, which represents an average annual rate of 1%. So, the energy performance and energy consumption of the building sector is targeted in advanced studies and policy making by the European Union and other developed countries [1,3]. The European Union, to minimize and to improve the energy efficiency of the building sector has applied some policies and established goals [4-6].

Nowadays, the external glazing envelope, mainly in offices and commercial spaces, are systematically composed by large glazed areas that lead to increase the energy consumption of the building and to visual discomfort to their occupants [7-9]. In terms of energy efficiency and indoor thermal regulation, these areas are presently an object of high-end research and application for enhancing building envelope [7,10,11].

Many studies, prototypes and developments have been done in the last years to increase the thermal and energy efficiency of windows. The improvements of the thermal performance of windows and glazed areas have been resourcing to new materials, new geometries and shapes and to the use of new techniques and technology in the glazing production.

The use of PCMs is currently a promising solution to improve the energy performance of building elements considering their capacity to store and release energy. This capacity contributes to minimize the maximum and minimum indoor air temperature peaks and to reduce the buildings energy demand [12-15].

## 2. OBJETIVES

The main goal of this work is to research and to evaluate the thermal performance of a window shutter with PCMs. The main objectives could be summarized by:

- development and depict a thermal energy storage system;
- present the testing apparatus and the results over the thermal behaviour and energy demand;
- results comparison of the reference window shutter versus the PCM window shutter.

## 3. SET-UP DEFINITIONS

The main structure of the window shutter is made of aluminium and four similar window shutters were built. The blades of two of the window shutters were filled with PCM (“PCM compartment” – compartment with the PCM window shutter) and the others two were left empty (“Reference compartment” – compartment with the reference window shutter). The window shutter is composed by insulation material (XPS), aluminium blades filled with PCM (or empty) and two main aluminium structures (one of each side) that supports the rotation system and all components.

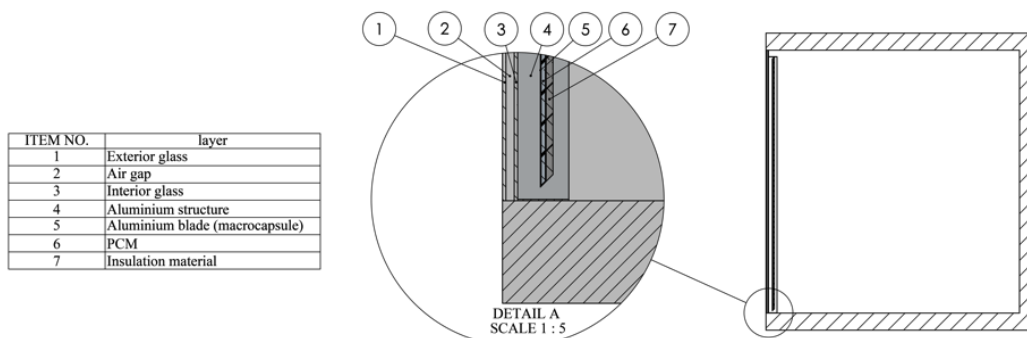

Figure 1. Composition of the test cell.



### 3.2 Materials properties

The properties of each material that composes the test cell were further used to defined numerical models (not presented in this document). Besides of the properties of the common materials defined before, the following table shows the thermal-physical properties of the PCM used for this experiment.

Table 1. Physical and thermal properties of the PCM.

$T_f$	Melting/solidification range	[°C]	27 – 29
$L_f$	Latent heat storage capacity $\pm 7,5\%$	[kJ.kg <sup>-1</sup> ]	245
$C_p$	Specific heat capacity	[kJ.kg <sup>-1</sup> .K <sup>-1</sup> ]	2
$\rho_s$	Mass density solid phase	[kg.m <sup>-3</sup> ]	880
$\rho_l$	Mass density liquid phase	[kg.m <sup>-3</sup> ]	770
$\lambda$	Thermal conductivity	[W.m <sup>-1</sup> .K <sup>-1</sup> ]	0.2
$\Delta V$	Volume expansion	[%]	12.5
$T_{fp}$	PCM Flash point	[°C]	165
$\nu$	Kinematic viscosity at 50°C	[m <sup>2</sup> .s <sup>-1</sup> ]	25.71x10 <sup>-6</sup>

## 4. CONCLUSIONS

The performance of a window shutter with PCMs was experimentally tested at full scale. The PCM provided an additional thermal inertia capacity for this compartment that is recorded by the indoor air temperatures and heat flux results attained. Based on the experimental campaign of two similar window shutter solutions oriented to the south, one considered as the reference and the other filled with PCM – during the summer and winter periods and located at Aveiro, Portugal – the main results of two selected weeks are exposed below.

### 4.1 Summer week

During testing period of the experimental campaign, 2<sup>nd</sup> to 9<sup>th</sup> of August, the test cell was submitted to average solar radiation of 237 [W.m<sup>-2</sup>] to 306 [W.m<sup>-2</sup>]. The external air temperature ranges from 13°C to 25°C. The following conclusions can be taken:

- During the charging and discharging process of the PCM, for each time step the window shutter with PCM can reduce the indoor compartment temperature about -22% to 18% (minimum and maximum value correspondently);
- The window shutter with PCM can decrease the maximum and minimum temperatures peaks about 6% and 11%, respectively. During this time, the use of PCM in the window shutter solution could increase 45min the time delay for the minimum temperature peak and one hour the time delay for the maximum temperature peak, compared to the reference compartment;
- The heat flux profiles show the PCM thermal regulation effect in the indoor temperatures.

### 4.2 Winter week

The main conclusion taken from the experimental results of the selected winter week are:

- The maximum temperature reduction provided by the compartment with the PCM shutter is 90% and is reached during the heating period when the PCM is storing energy;
- When the outdoor and indoor temperature drops below the set point solidification temperature, the PCM releases energy and improves the indoor temperature up to 35%;
- At the maximum indoor air temperature peak the temperature reduction of the compartment with the PCM shutter is about 30% to 40% over, but for the minimum indoor air temperature the improvement is practically null (both compartments have similar

- minimal temperatures);
- The maximum indoor temperature of the compartment with the PCM shutter is 37.2°C, which is 16.6°C lower than the indoor air temperature of the reference compartment and is reached 1:15h later;
  - Comparing the indoor temperatures over time, the temperature reduction can reach 90% (when the indoor air temperatures increases) and up to 35% (when the indoor air temperatures drops);
  - For the maximum indoor air temperature peak the difference between both compartments is 30% to 40%;
  - The minimum indoor air temperature peaks are similar.

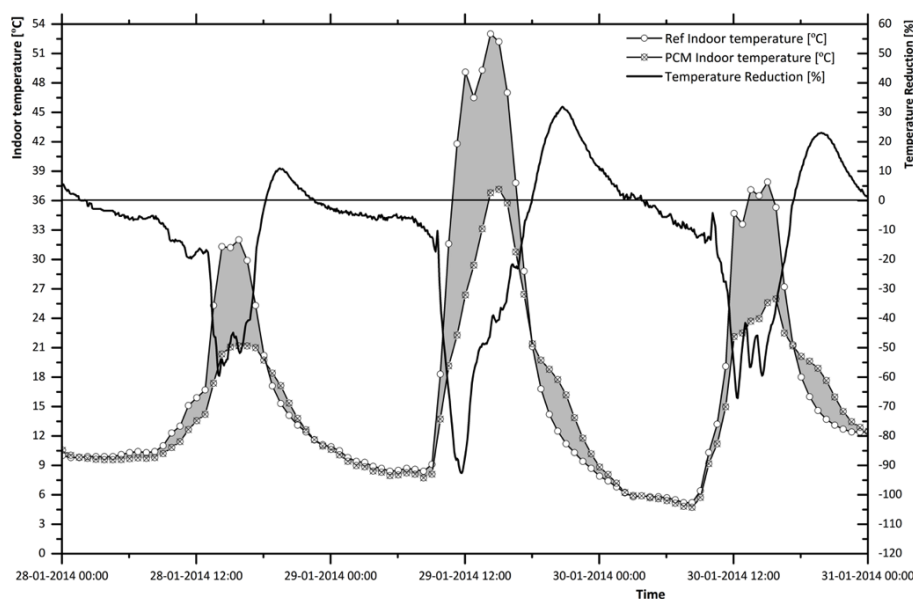

Figure 2. Indoor temperatures for the selected week during the winter season

For both compartments, and selected weeks, the overheating inside of the test cell was higher than the expected. During the day the PCM melted completely and stayed in this condition too long that it allowed to increase the compartment internal air temperature above comfortable conditions.

## REFERENCES

- [1] IEA (2017), World Energy Outlook 2017, OECD Publishing, Paris/IEA, Paris, <http://dx.doi.org/10.1787/weo-2017-en>.
- [2] C. Koo, S. Park, T. Hong, H.S. Park (2014), An estimation model for the heating and cooling demand of a residential building with a different envelope design using the finite element method, *Appl Energy* 115 (2014) 205–215.
- [3] S.M.C. Magalhães, V.M.S. Leal (2014), Characterization of thermal performance and nominal heating gap of the residential building stock using the EPBD-derived databases: The case of Portugal mainland, *Energy Build*, 70 (2014) 167–179.
- [4] Directive 2010/31/EU of the European Parliament and of the Council of 19 May 2010 on the energy performance of buildings. Official journal of the European Union, L 153 (2010) 13–35.
- [5] J. Bosch, F.X. Johnson, E. Clément, R. Mertens, N. Roubanis, *Panorama of energy – Energy statistics to support EU policies and solutions*, Eurostat Statistical Books, Luxembourg: Office for Official Publications of the European Communities, (2009).
- [6] European Union Commission Energy Topics. 1995-2015 13/05/2015; Available from: <https://ec.europa.eu/energy/en/topics/>.

- [7] F. Cappelletti, A. Prada, P. Romagnoni, A. Gasparella (2014), Passive performance of glazed components in heating and cooling of an open-space office under controlled indoor thermal comfort, *Build Environ* 72 (2014) 131–144.
- [8] M.G. Gomes, A.J. Santos, A.M. Rodrigues (2014), Solar and visible optical properties of glazing systems with venetian blinds: Numerical, experimental and blind control study, *Build Environ* 71(2014) 47–59.
- [9] J. Peng, L. Lu, H. Yang (2013), An experimental study of the thermal performance of a novel photovoltaic double-skin facade in Hong Kong, *Sol Energy* 97 (2013) 293–304.
- [10] S. Ghoshal, S. Neogi (2014), Advance glazing system – Energy efficiency approach for buildings a review, *Energy Procedia* 54 (2014) 352–358.
- [11] T.-P. Wang, L.-B. Wang, B.-Q. Li (2013), A model of the long-wave radiation heat transfer through a glazing, *Energy Build* 59 (2013) 50–61.
- [12] R. Baetens, B.P. Jelle, A. Gustavsen (2010), Phase change materials for building applications: A state-of-the-art review, *Energy Build* 42(9) (2010) 1361-1368.
- [13] L.F. Cabeza, A. Castell, C. Barreneche, A. de Gracia, A.I. Fernández (2011), Materials used as PCM in thermal energy storage in buildings: A review, *Renew Sustain Energy Rev* 15(3) (2011) 1675-1695.
- [14] H. Mehling and L.F. Cabeza, Heat and cold storage with PCM: an up to date introduction into basics and applications. Berlin, Germany: Springer (2008).
- [15] M.R. Anisur, M.H. Mahfuz, M.A. Kibria, R. Saidur, I.H.S.C. Metselaar, T.M.I. Mahlia (2013), Curbing global warming with phase change materials for energy storage, *Renew Sustain Energy Rev* 18 (2013) 23-30.

## THE SCORES PROJECT AND THE NEW COMPACT HYBRID STORAGE TECHNOLOGIES

J.M. Garcia<sup>1,2\*</sup> and L.M.R. Coelho<sup>1,2</sup>

<sup>1</sup> Mechanical Engineering Department, Escola Superior de Tecnologia de Setúbal/IPS  
Campus do IPS, Estefanilha, 2760-761 Setúbal

<sup>2</sup> CINEA -Research Centre for Energy and Environment

\* Correspondent author: João Garcia, joao.garcia@estsetubal.ips.pt

**Keywords:** PCM, hybrid storage, buildings, ambient heating.

**Abstract** *This paper describes the developments on the usage of PCM's in the SCORES project for air ambient heating purposes. The SCORES project is a newly launched research project supported by the European Commission under the Horizon 2020 programme for Research and Innovation (Call H2020-EEB-2017, Project No. 766464) with a duration of 48 months. The project consortium consists of twelve partners from seven European countries.*

### 1. INTRODUCTION

The main aim of the SCORES project [1] is to develop and demonstrate a building energy system including new compact hybrid storage technologies that optimizes supply, storage and demand of electricity and heat in residential buildings, increasing self-consumption of local renewable energy in residential buildings at the lowest cost and deferring investments in the energy grid. SCORES is coordinated by TNO and the project consortium consists of twelve partners from seven European countries.

### 2. GENERAL SPECIFICATIONS

SCORES will combine and optimize the multi-energy generation, storage and consumption of local renewable energy (electricity and heat) and grid supply, optimizing self-consumption of renewable energy and deferring investments in the energy grid, towards a zero-energy built goal. This hybrid energy system promotes a better use of available energy sources in two ways, at the local level increases the self-consumption of local renewable generation and at the global (energy grid) level introduce new sources of flexibility for the grids. At local level, increasing the local renewable energy generation in buildings with a high share of local consumption bridges the gap between supply and demand for both electricity and heat, considering that renewable energy is in principle abundant, but variably available, in order (i) not to inject useless electricity (or inject as little as possible) to the grid when the demand is low and (ii) not to lose energy (electricity or heat) that cannot be consumed. For this purpose SCORES develops and demonstrates local storage technologies for electricity and heat at short (hours-days) and long (weeks-months) time scales. At global level, SCORES will also increase the storage capacity of the grid as it enables home-owners to offer storage of energy in their homes (behind the meter) to the grid operator in order to provide an additional source of grid-

flexibility (*e.g.* the seamless exchange of energy in different forms). This will delay/decrease investments in the energy grids otherwise required for increasing power capacity reserves, by grid interconnection or reinforcement and by storage of electricity before the meter [1].

### 3. SCORES MAIN GOALS

SCORES targets several goals to achieve the objective pointed before: (i) to develop a technology of second life Li-ion batteries to be used for electricity storage in buildings; (ii) to develop compact thermal storage using a phase change material (PCM) associated with electric heater or air/air heat pump for space heating; (iii) to optimize and integrate in the developed system a high performance hot water heat-pump for multi-family buildings supplied by hybrid photovoltaic and solar collectors (PVT); (iv) to improve and optimize a Chemical Looping Combustion (CLC) heat storage technology (long term & seasonal storage); (v) to develop an integrated building energy management system (BEMS) that optimizes the operation of the different developed technologies with the energy supply from the grid and renewable sources and with the consumption profiles of heat and electricity.

### 4. PCM FOR AMBIENT HEATING

Three system configurations are established to represent the full range of use cases in the Northern (NE) and Southern (SE) European climatic zones. A NE residential building connected with a heat grid and using hot water for space heating, a SE residential building using (renewable) electricity for space heating and a NE residential building without a heat grid using solar energy for space heating. For the SE residential building using renewable electricity for space heating, the house is equipped with a combined PVT collector, generating local renewable energy that supplies the water-water heat pump with heat and electricity. The demonstration system includes PCM based thermal storage in individual electric heaters, as an additional storage technology in the hybrid system (Figure 1).

The use of PCM's for thermal storage with a phase transition around 100°C reduces the thermal losses compared to classic solutions. The usage of electric driven heating with intraday PCM heat storage can improve the efficiency of current electric heat storage systems. Research must be performed in the areas of heat loss reduction, volume reduction, mass reduction and reduction of the environmental impact of the storage solution all across its lifecycle. Alternatively, PCM storage in conjunction with an electric air-source heat pump has the potential to support domestic energy demand reduction whilst at the same time minimizing supply challenges for the electricity utilities if at an appropriate cost. For thermal comfort, the usage of advanced (PCM) materials coupled with an intelligent control strategy can improve the overall efficiency of the system.

A prototype of an efficient heat storage core using a new composite material associating a bio-sourced PCM and an efficient heat exchanger made out of aluminium foam is being developed. The use of PCM in a heat storage unit will contribute to two objectives in heating systems, it will balance the electric demand for typical residential houses, decreasing the electricity consumption during peak hours. The heat pump can operate outside peak hours charging the PCM heat storage. During peak hours the heat pump can be switched off or decrease its electrical consumption, the PCM will provide the missing energy during that period. It will increase the effective use of solar energy from the PV or PVT collectors. During the sunny hours the heat pump can charge the PCM heat

storage and the PCM can provide this energy during periods with low ambient temperature. Also if an air to air heat pump is used, the heat pump can extract useful heat at outside temperature down to  $-15\text{ }^{\circ}\text{C}$ , but its efficiency (electrical consumption) is strongly reduced at low temperatures. This air to air heat pump technology can improve the overall efficiency of an electric heater with PCM storage.

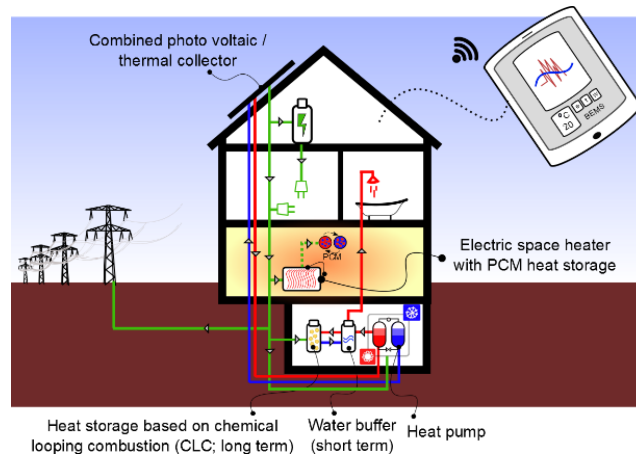

Figure 2. Southern Europe demosite configuration.

## 5. CONCLUSIONS

In order to reach the benefits described above in SCORES, organic bio-sourced PCM's have been studied and the most adequate one will be selected, taking into account the melting temperature, latent heat, heat capacity, thermal conductivity and other important thermal characteristics. Ways to increase the thermal conductivity by means of aluminum foams with PCM's will be studied. Detailed numerical and experimental tests will be done for geometry and heat exchanger configurations in order to optimise the heat transfer rate and the heat storage capacity.

The project leading to this application has received funding from the European Union's Horizon 2020 research and innovation programme under Grant Agreement No. 766464. This website reflects only the author's view and the European Commission is not responsible for any use that may be made of the information it contains.

## REFERENCES

- [1] SCORES\_first press release, (2018).

## A DEGRADATION MODEL AND THE ASSOCIATED ACTIVATION ENERGY OF ORGANIC PHASE CHANGE MATERIALS

**Daniela Silva<sup>1</sup>, Tiago Vieira<sup>1</sup>, Nuno Rocha<sup>1\*</sup>, Marina Torres<sup>1</sup>, Carla Gomes<sup>1</sup>, Susana Sousa<sup>1</sup>, Joana Guedes<sup>1</sup>, Marcela Teixeira<sup>2</sup> and Nuno Correia<sup>1</sup>**

<sup>1</sup> INEGI – Institute of Science and Innovation in Mechanical and Industrial Engineering, Campus FEUP, Rua Dr. Roberto Frias, 400, 4200-465 Porto

<sup>2</sup> CABELTE – Cabos elétricos e telefónicos, S.A., Rua de Espírito Santo, 4410-420 VN de Gaia

\* Correspondent author: Nuno Rocha, nrocha@inegi.up.pt

**Keywords:** Activation energy of degradation, melting latent heat, lifetime, phase-change materials (PCM), high-voltage (HV) power cables.

***Abstract** This research work has been carried out in the scope of a development project for maximum current enhanced High Voltage (HV) power cables, to increase their durability in operation by the introduction of PCM for improved thermal and current management. Organic PCM were selected since they have the most suitable characteristics for the application. Simultaneously, a thermal model was created to design the new HV cables allowing to study current improvements as function of the cable internal temperatures. A prototype for this new cable was produced in CABELTE's manufacturing line through the introduction of the required process adjustments. Nevertheless, one of the challenges on the use of PCM is the loss of heat storage capacity with temperature cycles. Two PCM were aged aiming to address their deterioration and latent heat reduction, for which a mathematical model was proposed. Furthermore, kinetic models were used to assess materials lifetime through energy of activation of degradation, since these materials are expected to increase the duration under operation compared to conventional HV cables. The obtained results confirm the suitability of these materials to the targeted application.*

### 1. INTRODUCTION

Power cables of High Voltage (HV) are typically designed for lifetimes of 30 years and their maximum electrical energy transport is constrained by the isolation polymer XLPE (crossed-linked polyethylene) degradation temperature (90 °C). In addition, even though HV cables are widely used in power systems, it is known that polymeric materials existing in the cable structure experience aging when subjected to thermal stress, leading to failure [1]. Aiming to increase current transport, expand lifespan and reduce heat loss, the feasibility of inserting a PCM was evaluated. Once inside the cable, the PCM should last as long as the cable and support the same temperature variations to which the cable is subjected.

Amongst PCM are the organic compounds which present a recognised chemical inertness and thermal stability. For those reasons, a paraffin and a commercial PCM were chosen and tested in order to assess their latent heat over thermal cycling and to predict their lifetime, verifying its suitability for the desired application.

## 2. PCM SELECTION

The sort of PCM were firstly identified as being organic, inorganic or eutectics. Considering advantages and disadvantages and regarding not only the material itself but also its end-use, organic PCM were selected due to its stability, market availability, no components separation and phase-change temperature. Among these, organic paraffins and waxes were further evaluated and applied into the new HV cable structure.

## 3. CABLE PRODUCTION AND NEW STRUCTURE

CABELTE's manufacturing line was modified to include the injection of PCM inside the cable armour (Figure 1a). This area was selected since it has naturally void areas, which meant that the cable final diameter would not be affected by the introduction of the PCM [2]. Additionally, a supporting to design thermal model was created, being possible to confirm that with the PCM in cable armour (Figure 1b) the current transferred through tested cables was at least 5% higher without compromise temperatures within the cable, namely XLPE 90 °C limitation.



Figure 1. (a) CABELTE's production line with PCM introduction in cable armour;  
(b) Produced cable with PCM.

The produced and tested HV cable with PCM proved the feasibility of the proposed concept and remarked the improvements in operation: current increase and temperature reduction.

## 4. PCM: DURABILITY, EFFICIENCY LOSS AND LIFETIME

### 4.1 Methodology

A commercial paraffin, *Parafina refinada 57-59* (*Casa das Essências*, Portugal) and a commercial paraffin wax, RT82, (Rubitherm® Technologies GmbH) were used. Materials were subjected to accelerated aging up to 1000 cycles in an oven. Aged samples were selected and its melting enthalpy was measured in a DSC equipment (model Q20, TA Instruments, USA), in an inert atmosphere. Moreover, fresh samples of paraffin and RT82 were subjected to TGA analysis (model STD600, TA, Instruments, USA) under an inert atmosphere.

### 4.2 Phase change enthalpy during cycling and degradation model

The obtained DSC thermograms allowed to calculate the melting enthalpy, as well as to quantify its variation over the number of phase-change cycles (Figure 2a) [3]. The obtained data proved that there is a decrease of selected materials with temperature cycles and, therefore, a reduction of potential of heat storage. Furthermore, the acquired data was used to establish a melting enthalpy evolution with phase change cycles model (Figure 2b), which was then compared with experimental data, being observed a similar behaviour.

The selected PCM presented a 10% reduction of the melting latent heat after approximately 900 thermal cycles. Applying the resulting proposed model for the 10000<sup>th</sup>



cycle it is expected only an additional 3% decrease.

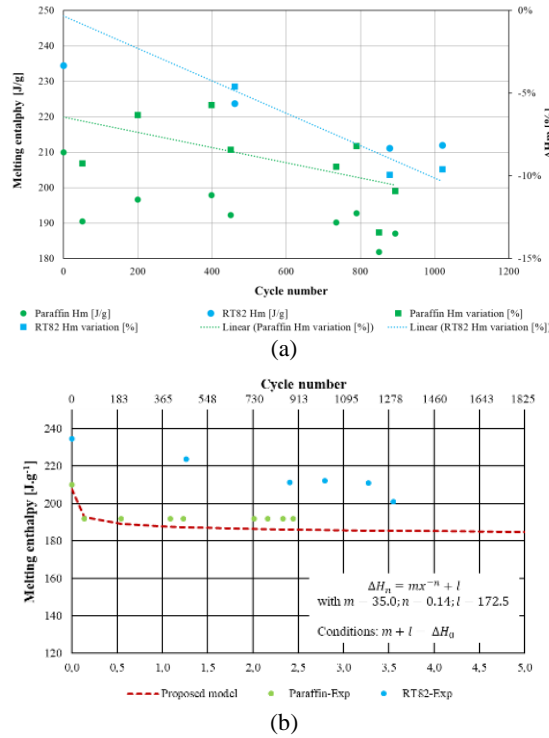

Figure 2. (a) Melting enthalpy over temperature aging cycles; (b) Proposed model.

### 4.3 Lifetime

The lifespan of paraffin and RT82 were also studied based on their activation energy of degradation (supported on data collected through TGA) to understand the impact on the PCM of using it a long period of time at above ambient temperatures [4]. At 50 °C, paraffin wax would be stable for 25 years, while RT82 would last for 80 years; however, if materials were constantly subject to 90 °C, their lifespan would decrease exponentially to 3.5 months and 1.5 years, respectively.

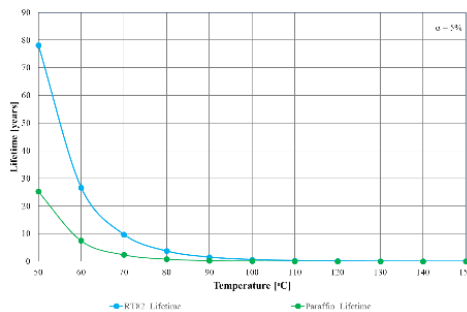

Figure 3. Lifetime plots based on a weight loss of 5% at various temperatures – paraffin and RT82.

## 5. CONCLUSIONS

The research and development work that was carried out was able to demonstrate it is possible to achieve a greater efficiency HV cable, when compared with conventional cables, through the use of PCM material as heat management system. Secondly, the required modifications in

the production line were implemented and it was possible to obtain a prototype of a new cable for further testing. The performed tests proved the feasibility of reduce HV cables temperature with the insertion of PCM. The obtained test results are evidence of the suitability of these type of materials to be used in the targeted application, although for the expected time of operation other ones should be evaluated.

### **Acknowledgements**

The authors wish to acknowledge NORTE-01-0145-FEDER-000022-SciTech-Science and Technology for Competitive and Sustainable Industries, co-financed by Programa Operacional Regional do Norte (NORTE2020), through European Regional Development Fund (ERDF) and also project CATER – Project Number 009974 cofunded by the Norte regional operational program (P2020) through ERDF.

### **REFERENCES**

- [1] R. Sarathi, S. Das, C.R.A. Kumar, R. Velmurugan (2004), Analysis of failure of crosslinked polyethylene cables because of electrical treeing: a physicochemical approach, *J Appl Polym Sci* 92 (2004) 2169–2178.
- [2] M.P. Sousa, M.M. Teixeira, P.M. Ribeiro, C.S. Gomes, N.P. Rocha, D.T. Silva, T.A. Vieira (2018), Cabo eléctrico: Patent number 110501A, 2018.
- [3] J. Gasia, L. Miró, A. de Gracia, C. Barreneche, L.F. Cabeza (2016), Experimental evaluation of a paraffin as phase change material for thermal energy storage in laboratory equipment and in a shell-and-tube heat exchanger, *Appl Sci* 6(4) (2016) 112.
- [4] P. Liu, J. Xu (2017), Nonisothermal degradation kinetics and life prediction of pendent phenyl containing polyarylate, *J Macro Sci-Phys* 56(1) (2017) 1–11.

## BEESWAX AS PHASE CHANGE MATERIAL: CHEMICAL MODIFICATION AND MIXTURES WITH HYDROGENATED WASTE COOKING OIL AND WITH PARAFFIN

João A. Baptista<sup>1\*</sup>, M. Ermelinda S. Eusébio<sup>1</sup> and Mariette M. Pereira<sup>1</sup>

<sup>1</sup> Centro de Química, Departamento de Química, Faculdade de Ciências e Tecnologia, Universidade de Coimbra, Rua Larga 3004-516

\* Correspondent author: João A. Baptista, j.agria.baptista@gmail.com

**Keywords:** Beeswax, transesterification, hydrogenated waste cooking oil, paraffin.

**Abstract** *To evaluate the beeswax potential to be used as a phase change material (PCM), in this work we present an investigation on the thermal behavior of pure beeswax and of some beeswax based materials.*

Beeswax is a natural product made of several compounds, mainly alkanes, alkenes, free fatty acids and fatty acids under the form of esters, diesters and hydroxiesters. In this work, beeswax from a Portuguese production in Alentejo was characterized by GC-MS [1] and the thermal behavior was evaluated for its potential use as a PCM. Transesterification of beeswax esters to methyl esters was carried out in order to modify the beeswax thermal properties. Moreover, mixtures of beeswax with hydrogenated waste cooking oil and with paraffin were also evaluate as potential PCMs [2].

The beeswax thermal behavior was studied by differential scanning calorimetry, DSC, in heating/cooling cycles from ambient temperature to complete melting at a scanning rate  $|\beta| = 5 \text{ }^\circ\text{C}\cdot\text{min}^{-1}$ . Phase transition extending from  $\approx 30$  to  $70^\circ\text{C}$ , with a melting enthalpy  $\Delta H = (166 \pm 7) \text{ kJ/kg}^{-1}$ , and peak temperature  $T_p = (65.2 \pm 0.6) \text{ }^\circ\text{C}$  was observed (Figure 1 and Table 1). Even with a wide transition, the beeswax showed some interesting properties for its use as a PCM, such as a low undercooling and a high melting enthalpy. The onset of the transition in the transesterified beeswax samples is higher ( $T_i = 43 \text{ }^\circ\text{C}$ ) and the melting enthalpy increased by 12% when compared to the original beeswax, while the low undercooling was maintained.

Beeswax mixtures with hydrogenated waste cooking oil were also studied by DSC. The heterogeneous catalytic hydrogenation of waste cooking oils (and of virgin oil, for comparison) was successfully achieved [3] as confirmed by  $^1\text{H-NMR}$ . The (beeswax + hydrogenated waste cooking oil) mixtures did not showed the ideal behavior of a conventional PCM, due to the undesirable undercooling and irreproducible behavior of crystallization of the liquid phase, resulting from the polymorphism of triglycerides [4]. After 24 hours at ambient temperature, the mixtures crystalized from melt resume the thermal behavior of the initial mixture.

Finally, beeswax mixtures with commercial paraffin in different proportions, were also investigated (an example is shown in Figure 2). These mixtures are promising for potential use as a PCM, showing a lower peak temperature (by  $5^\circ\text{C}$ ), and a higher melting enthalpy

(6%) than the original beeswax. In addition, they showed a smaller variation in volume during phase transitions when compared to the paraffin [2] – 50% smaller volume variation for the mixture with 40% beeswax.

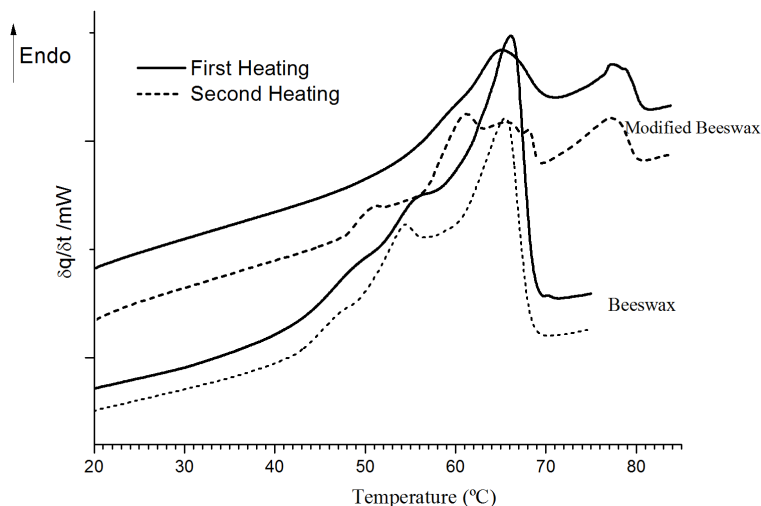

Figure 1. DSC thermograms obtained in the first and second heating runs carried out on beeswax and on transesterified beeswax samples, scanning rate  $\beta = 5^{\circ}\text{C}\cdot\text{min}^{-1}$ .

Table 1. Relevant thermal behavior data obtained in consecutive heating runs performed by DSC on beeswax and transesterified beeswax samples.

	First Heating				Second Heating			
	$T_i/^{\circ}\text{C}$	$T_f/^{\circ}\text{C}$	$T_p/^{\circ}\text{C}$	$\Delta H/\text{kJ}\cdot\text{kg}^{-1}$	$T_i/^{\circ}\text{C}$	$T_f/^{\circ}\text{C}$	$T_p/^{\circ}\text{C}$	$\Delta H/\text{kJ}\cdot\text{kg}^{-1}$
Beeswax (n=5)	$31.3 \pm 0.4$	$70.5 \pm 1.4$	$65.2 \pm 0.6$	$170.6 \pm 3.4$	$31.8 \pm 1.2$	$69.3 \pm 1.3$	$64.9 \pm 0.5$	$160 \pm 4.8$
Transesterified Beeswax (n=4)	$43.1 \pm 2.6$	$78.4 \pm 0.7$	$60.3 \pm 17$	$206.7 \pm 23$	$42.5 \pm 4.4$	$78.1 \pm 0.4$	$58.8 \pm 0.2$	$203 \pm 17$

$T_i$  – Initial Temperature,  $T_f$  – End Temperature,  $T_p$  – Peak Temperature,  $\Delta H$  – Melting Enthalpy.

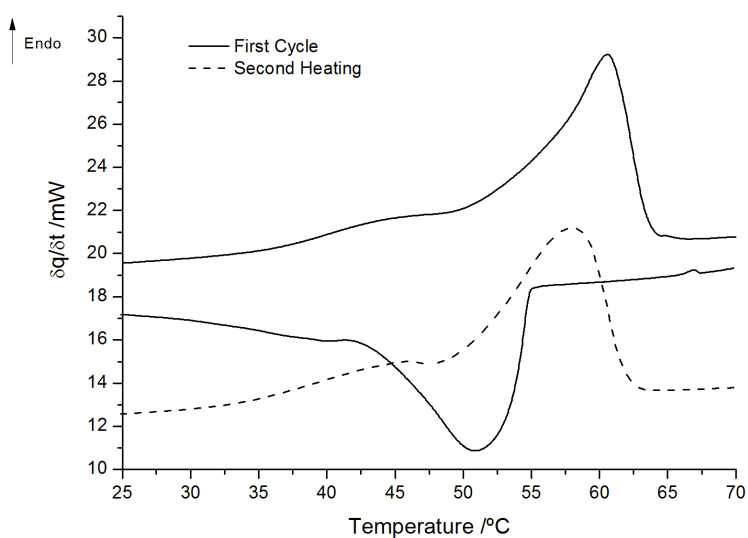

Figure 2. Thermograms obtained in heating/cooling/heating cycles for a (beeswax + paraffin) mixture (6:4 w/w),  $|\beta| = 5^{\circ}\text{C}\cdot\text{min}^{-1}$ .

## REFERENCES

- [1] J.J. Jiménez, J.L. Bernal, S. Aumente, L. Toribio, J. Bernal Jr. (2003), Quality assurance of commercial beeswax II. Gas chromatography–electron impact ionization mass spectrometry of alcohols and acids, *J Chromatogr A* 1007(1-2) (2003) 101–116.
- [2] A. Sharma, V.V. Tyagi, C.R. Chen, D. Buddhi (2009), Review on thermal energy storage with phase changematerials and applications, *Renew Sustain Energy Rev* 13(2) (2009) 318–345.
- [3] M.M. Dell’Anna, M. Gagliardi, P. Mastrorilli, G.P. Suranna, C.F. Nobile (2000), Hydrogenation reactions catalysed by a supported palladium complex, *J Mol Catal A Chem* 158(2) (2000) 515–520.
- [4] L. Hernqvist (1990), Polymorphism of triglycerides a arystallographic review, *Food Structure* 9(1) (1990) 39–44.

# **ANNEX: BOOK OF POSTERS**



U C

# Seminar - PCMs4Buildings

## PCMs: Thermophysical characterization and buildings' applications

# Systems with PCM-filled rectangular cavities for the storage of solar thermal energy for buildings: the case of the PCMs4Buildings project

N. Soares<sup>1,2\*</sup>, A.G. Lopes<sup>1</sup>, M. Gonçalves<sup>2</sup>, A.R. Gaspar<sup>1</sup>, C. Martins<sup>2</sup>, T. Matias<sup>3</sup>, P. Santos<sup>2</sup>, P.N. Simões<sup>3</sup>, L. Durães<sup>3</sup>, J.J. Costa<sup>1</sup>

<sup>1</sup> ADAI, LAETA, Department of Mechanical Engineering, University of Coimbra, Coimbra, Portugal

<sup>2</sup> ISISE, Department of Civil Engineering, University of Coimbra, Coimbra, Portugal

<sup>3</sup> CIEPQPF, Department of Chemical Engineering, University of Coimbra, Portugal

\* Correspondent author: Nelson Soares, nelson.soares@dem.uc.pt

## Major Goals

- To propose new TES systems for improving the energy performance of existing systems and/or to take advantage of solar thermal energy for reducing cooling and heating energy demand in buildings;
- To create an active multidisciplinary lab provided with the skills and equipments necessary to study new passive TES systems incorporating PCM-filled rectangular cavities for building applications;
- To create a dynamic organization scheme to cover all the research steps necessary for the study of new TES systems, from the thermophysical characterization of the materials to the final experimental and numerical evaluation of the thermal performance of some prototypes.

## Methodology – Main Tasks

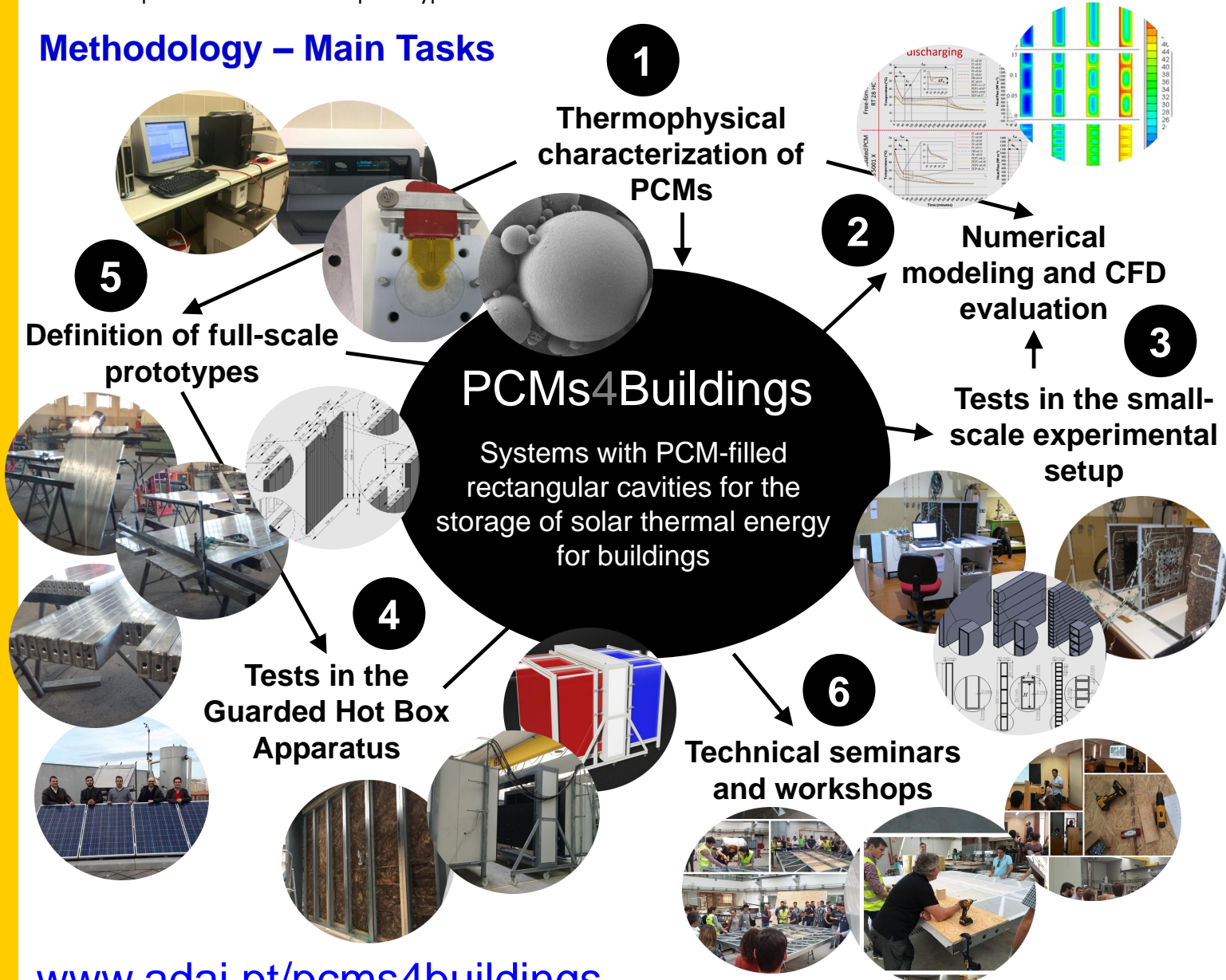

[www.adai.pt/pcms4buildings](http://www.adai.pt/pcms4buildings)

This project is supported by FEDER funds through the COMPETE 2020 - Operational Programme for Competitiveness and Internationalization (POCI), and by Portuguese funds through FCT in the framework of the project POCI-01-0145-FEDER-016750 | PTDC/EMS-ENE/6079/2014.

Cofinanciado por:



14-15 June, 2018

Department of Chemical Engineering  
University of Coimbra





# Thermophysical characterization of commercial paraffin-based PCMs for low temperature thermal energy storage applications

## Seminar - PCMs4Buildings

### PCMs: Thermophysical characterization and buildings' applications

Telma Matias<sup>1</sup>, Nelson Soares<sup>2,3</sup>, Isabel Campos-Gonçalves<sup>1</sup>, José J. Costa<sup>2</sup>, Pedro N. Simões<sup>1</sup> and Luisa Durães<sup>1\*</sup>

<sup>1</sup> CIEPQPF, Dept. Chem. Eng., University of Coimbra, Rua Silvío Lima, 3030-790 Coimbra, Portugal

<sup>2</sup> ADAI, LAETA, Dept. Mech. Eng., University of Coimbra, Rua Luís Reis Santos, 3030-788 Coimbra, Portugal

<sup>3</sup> ISE, Dept. Civil Eng., University of Coimbra, Rua Luís Reis Santos, 3030-788 Coimbra, Portugal

\*Correspondent author: Telma Matias, tmatias@eq.uc.pt; Luisa Durães, luisa@eq.uc.pt

### Motivation and Goals

Data on thermophysical properties of commercial phase change materials (PCMs) is fundamental for the design and modelling of low temperature thermal energy storage applications. However, the data provided by manufacturers are frequently insufficient and/or uncertain.

- Evaluation of thermal conductivity of free and microencapsulated PCMs at several temperatures (0-50°C) including the phase change range;
- Evaluation of latent heat of fusion, specific heat and melting/solidification temperatures of commercial PCMs.

### Methodology

Table 1. Commercial PCMs used in this work and their specifications (ME - microencapsulated).

PCM	Type	Manufacturer	$T_{melting}$ (°C)	$\Delta H_{melting}$ (J/g)
MPCM 18D	ME	Microtek laboratories	18	180 - 190
MPCM 24D	ME	Microtek laboratories	24	154-164
MPCM 28D	ME	Microtek laboratories	28	180-190
DS 5001 X	ME	BASF	26	110
PCM 18P	Bulk	Microtek laboratories	18	205-215
PCM 24P	Bulk	Microtek laboratories	24	165-175
PCM 28P	Bulk	Microtek laboratories	28	195-205
RT 25 HC	Bulk	Rubitherm	25	230
RT 28 HC	Bulk	Rubitherm	28	250

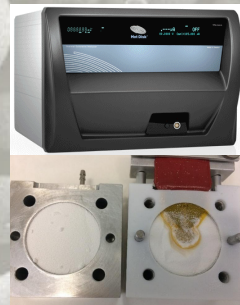

Figure 1. Hot Disk TPS 2500 S and liquids' sample holder full with PCM DS 5001 X.

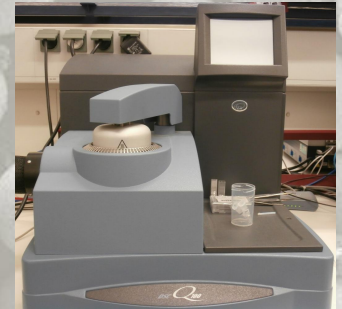

Figure 2. MDSC from TA instruments, model Q100.

### Results

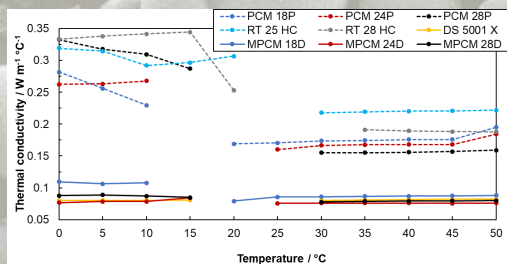

Figure 2. Thermal conductivities of commercial PCMs measured by the TPS method (Hot Disk).

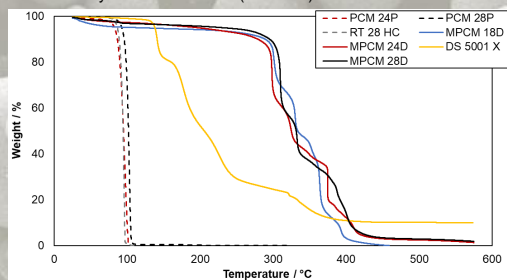

Figure 3. HiRes-TGA of commercial PCMs (rate: 2 °C min<sup>-1</sup>).

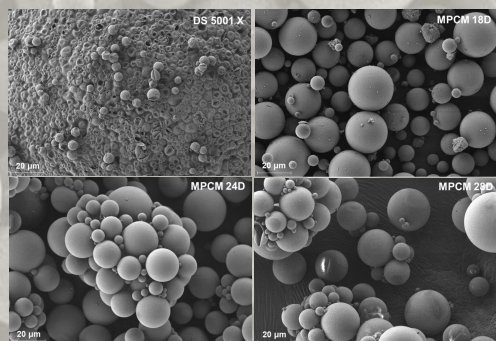

Figure 4. SEM images of Microencapsulated PCMs.

Table 2. Melting/solidification temperature,  $C_p$  and latent heat of the commercial PCMs.

PCM	$T_{melting}$ (°C)	$T_{solidification}$ (°C)	$C_{p,solid}$ (J/g °C)	$C_{p,liquid}$ (J/g °C)	$\Delta H_{melting}$ (J/g)	$\Delta H_{solidification}$ (J/g)
MPCM 18D	16.74	14.04	2.52	2.09	99.18	86.30
MPCM 24D	21.82	20.95	2.77	2.25	171.81	179.26
MPCM 28D	25.76	24.38	1.92	2.08	147.42	142.88
DS 5001 X	24.91	22.49	2.25	2.02	84.24	62.57
PCM 18P	16.18	14.40	1.49	1.60	116.06	109.15
PCM 24P	22.13	21.71	2.05	1.74	133.13	132.48
PCM 28P	26.32	25.33	1.92	2.13	164.74	129.68
RT 25 HC	25.53	24.22	1.29	1.37	88.62	82.38
RT 28 HC	27.82	25.89	1.45	1.88	89.84	53.81

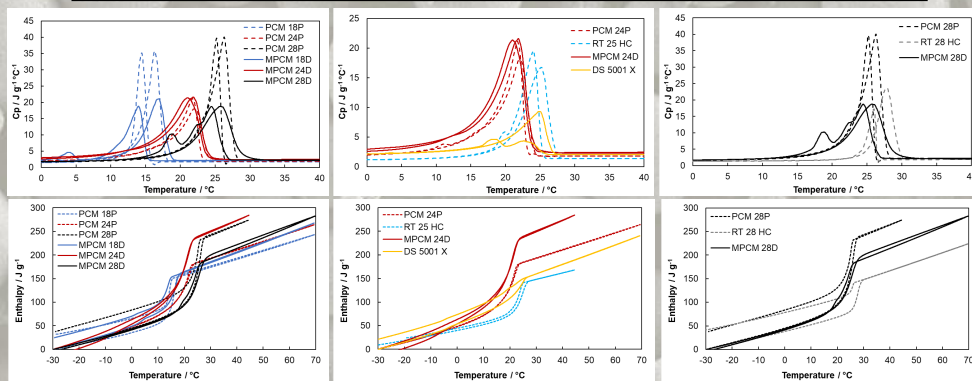

Figure 5. Specific heat and enthalpy curves of commercial PCMs measured by MDSC (rate: 2 °C min<sup>-1</sup>).

### Conclusions

- Thermal conductivity of free PCMs is higher and more discriminated than that of microencapsulated PCMs;
- Lower conductivity of the polymer shell in microencapsulated PCMs may lower the efficiency of this kind of PCMs, since it hinders the heat transfer;
- The position of the  $C_p$  peaks is consistent with the temperature indicated by the supplier for the phase change temperature, but usually some degrees lower;
- The latent heat provided by the supplier is normally higher than the evaluated by MDSC;
- Residual leak of PCM material during heating/cooling stages occurs at low temperatures, as confirmed by HiRes-TGA.

14-15 June, 2018

Department of Chemical Engineering  
University of Coimbra



This project is supported by FEDER funds through COMPETE 2020 - POCI, and by Portuguese funds through FCT in the framework of the project POCI-01-0145-FEDER-016750 | PTDC/EMS-ENE/6079/2014.

Financiado por:





# The importance of the thermophysical characterization of microencapsulated PCMs for the numerical analysis of the heat transfer with solid-liquid phase change

N. Soares<sup>1,2\*</sup>, A. Luzio<sup>1</sup>, T. Matias<sup>3</sup>, P.N. Simões<sup>3</sup>, L. Durães<sup>3</sup>, J.J. Costa<sup>1</sup>

<sup>1</sup> ADAI, LAETA, Department of Mechanical Engineering, University of Coimbra, Coimbra, Portugal

<sup>2</sup> ISISE, Department of Civil Engineering, University of Coimbra, Coimbra, Portugal

<sup>3</sup> CIEPQPF, Department of Chemical Engineering, University of Coimbra, Portugal

\*Correspondent author: Nelson Soares, nelson.soares@dem.uc.pt

## Framework

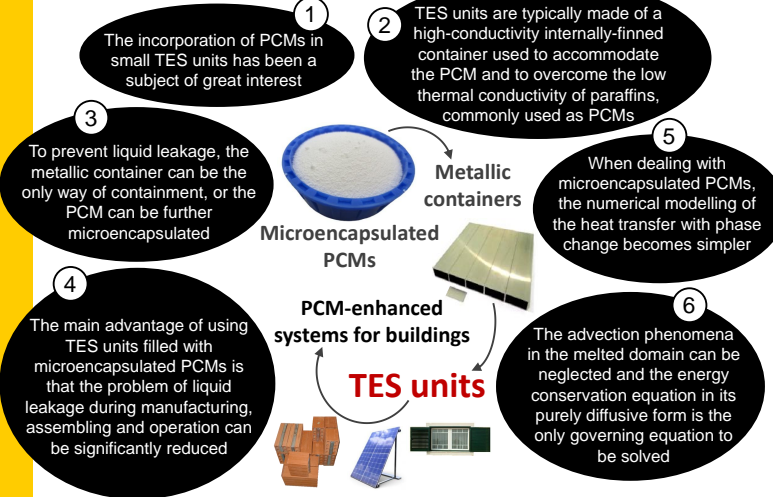

## Experimental campaign

Experiments vs. numerical physical domain and boundary conditions

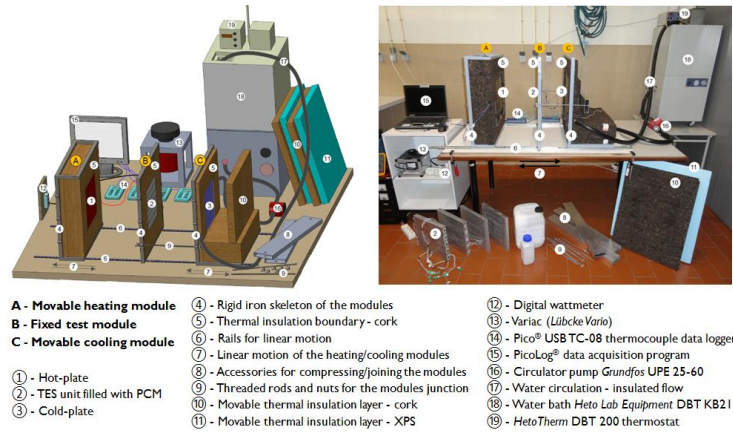

Figure 1. Sketch and photographic view of the experimental setup previously developed by the authors.

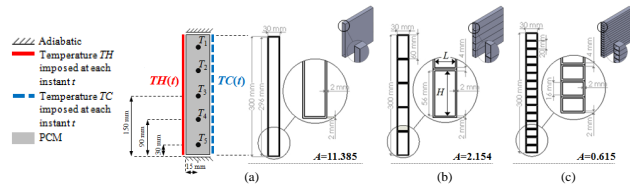

Figure 2. (a) Sketch of the physical model and imposed boundary conditions for the 1-single cavity TES unit. Sketch and dimensions of the TES units with (b) 5-cavities and (c) 15-cavities.

- In the numerical model, the boundary conditions imposed on the vertical surfaces reproduce the time evolution of the average temperature measured on the left and right faces of the TES unit during the experiments,  $TH(t)$  and  $TC(t)$  respectively;
- The top and bottom frontiers are set to be **adiabatic**;
- The time evolution of  $T_f$  experimentally obtained is used for **numerical validation purposes**;
- To evaluate the influence of the aspect ratio of the cavities ( $A$ ) during melting and solidification processes, as well as the influence of adding metallic fins, three different configurations of the TES unit are considered.

## Acknowledgment

This project is supported by FEDER funds through the COMPETE 2020 - Operational Programme for Competitiveness and Internationalization (POCI), and by Portuguese funds through FCT in the framework of the project POCI-01-0145-FEDER-016750 | PTDC/EMS-ENE/6079/2014.

## Main Goals

- To develop 2D numerical models based on the **additional heat source method** and the **effective heat capacity method** to evaluate the heat transfer with melting/solidification of a microencapsulated PCM – Micronal® DS 5001 X – contained in rectangular-sectioned vertical cavities;
- To validate the numerical results against previous experimental results;
- To evaluate which method is better to simulate the heat transfer with phase changes;
- To assess which kind of function for the variation of the effective heat capacity with temperature is more suitable to simulate the kinetics of the solid-liquid phase change processes and to determine the stored/released energy during a charging/discharging cycle;
- To experimentally evaluate the main thermophysical properties of the microencapsulated PCM used in the experiments, which are necessary for the numerical modeling.

## Thermophysical properties of the PCM

**Thermal conductivity** – the values measured of about  $0.08\text{--}0.086\text{ W}\cdot\text{m}^{-1}\cdot\text{K}^{-1}$  are 2.3–2.5 times lower than those typically specified in the literature for organic PCMs ( $\approx 0.2\text{ W}\cdot\text{m}^{-1}\cdot\text{K}^{-1}$ ).

**Volumetric mass density** – the TES units were weighed empty and filled in order to determine the weight of the PCM. As the volume of the cavities is known a priori, the  $\rho$ -value was estimated for each experiment (489–538  $\text{kg}/\text{m}^3$ ). These values are 40–115% bigger than that specified in the datasheet of the material (250–350  $\text{kg}/\text{m}^3$ ), which can significantly affect the numerical predictions.

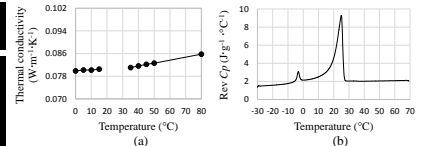

Figure 3. (a) Variation of the thermal conductivity of the PCM with the evolution of temperature – measurements with the Hot Disk TPS 2500 S equipment. (b) Specific heat of the PCM measured by MDSC (charging rate:  $2\text{ }^\circ\text{C}\cdot\text{min}^{-1}$ ).

**Heat capacity** – the position of the peak of  $C_p$  is consistent with the temperature indicated by the suppliers. However, the phase transition occurs in a wide temperature range, which must be considered in the numerical simulations.

## Numerical approach

Methods used:

➔ **Additional heat source method**

$$\begin{cases} \frac{\partial(\rho C_p T)}{\partial t} = \frac{\partial}{\partial x} \left( k \frac{\partial T}{\partial x} \right) + \frac{\partial}{\partial y} \left( k \frac{\partial T}{\partial y} \right) + S(f) \\ S(f) = -\rho \frac{\partial f}{\partial t} L \end{cases}$$

- ➔ **Reverse  $C_p$**  – specific heat as a function of temperature (Figure 3b)
- ➔ **Effective heat capacity method** – the latent heat is modeled in the energy conservation equation as an artificially inflated specific heat within the temperature interval where phase change occurs

- Rectangular profiles (a) –  $\square$
- Triangular profile (b) –  $\Delta$
- Triangular corrected profile ( $2L$ ) –  $\Delta^*$  and  $\Delta^{**}$  (varying  $\Delta T_1$  and  $\Delta T_2$ )
- Triangular adjusted profile (c) –  $\Delta_{adj}$  (varying  $\Delta T_1$  and  $\Delta T_2$  automatically)

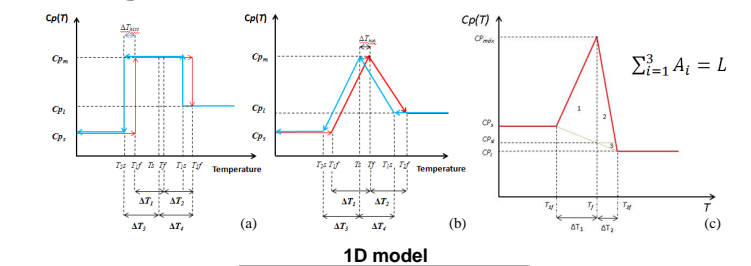

## Results

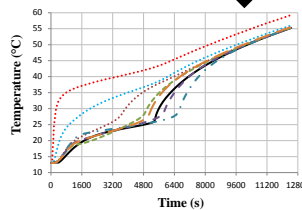

Figure 4. One-dimensional model – time evolution of the boundary conditions specified during charging. Evolution of  $T_{f,num}$  calculated with different approximations of the effective heat capacity in comparison with  $T_{f,exp}$ .

	$\square$	$\Delta$	$\Delta^*$	$\Delta^{**}$	$\Delta_{adj}$
Stored Energy - E (kJ)	7.70	10.10	11.40	12.40	9.50
Theoretical Stored Energy (kJ)	9.8				
ER $T_{f,num}$ (%)	10.4	4.4	2.0	5.4	3.4
ER E (%)	20.9	3.7	17.0	27.5	3.1

## 2D model – 5-cavities TES unit

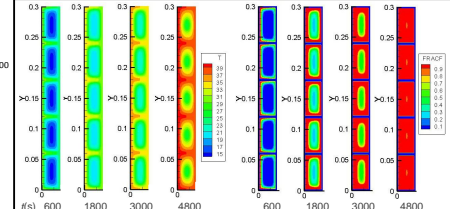

Figure 5. Time evolution of both the temperature distribution and the melted fraction of PCM during charging – Triangular adjusted profile –  $\Delta_{adj}$ .

14-15 June, 2018

Department of Chemical Engineering  
University of Coimbra





# PCMs in Polyurethane Foam Layers: From the individual layer to building solutions

Romeu Vicente<sup>1\*</sup>, Cláudia Amaral<sup>1</sup>, Paula Marques<sup>2</sup> and Ana Barros-Timmons<sup>3</sup>

## Seminar - PCMs4Buildings

### PCMs: Thermophysical characterization and buildings' applications

<sup>1</sup> RISCO, Civil Engineering Department, University of Aveiro, Campus Universitário de Santiago, 3810-193 Aveiro, Portugal

<sup>2</sup> TEMA, Department of Mechanical Engineering University of Aveiro, Campus Universitário de Santiago, 3810-193 Aveiro, Portugal

<sup>3</sup> CICECO, Aveiro Institute of Materials, Department of Chemistry, University of Aveiro, Campus Universitário de Santiago, 3810-193 Aveiro, Portugal

\* Romeu Vicente, Tel.: +351 234 370 845, Fax: +351 234 370 094, email: romvic@ua.pt

### Motivation and Goals

The main aim of this work is to give new insights on the thermal conductivity measurements of rigid polyurethane foams (RPU) foams with PCMs using three different approaches, especially in the temperature range during mPCM phase change transition (solid/liquid state). To evaluate the influence of mPCMs incorporation in the RPU foam in terms of the thermal conductivity, the selected experimental characterization tests were: i) hot box heat flux meter approach, ii) guarded hot plate approach, and iii) transient plane source approach.

### Work plan / Methodology

The standard PU foam was prepared using 100 parts of polyol (Purotherm 463 RG 48) and 130 parts of isocyanate (puronate 900). Both components were mixed for 10 seconds with a blade stirrer at 2000 rotations / second. The PCM (up to 12.5 parts = 5%) and flame retardant (melamine) were incorporated in the polyol fraction prior to the PU foam formation by mixing for 55 sec. To avoid high shear forces, a blade stirrer with a lower rotation rate (1000 rotations/second) that does not touch the bottom of the beaker was used. To evaluate the influence of PCMs (Micronal®DS 5001X) in the PU foam layer, the following experimental characterization tests were carried out over 2 specimens:

- Rigid PU foam with melamine and without PCM (designated as RPU);
- Rigid PU foam with melamine and with 5wt% PCM (designated as RPU\_5PCM).

Table 1 – DSC results of the mPCM and RPU\_5PCM foam specimens

Specimens	Melting			Solidification		
	Transition temperature $T_{1m}$ (°C)	Melting temperature $T_m$ (°C)	Melting latent heat $\Delta H_m$ (J/g)	Transition temperature $T_{1s}$ (°C)	Solidification temperature $T_s$ (°C)	Solidification latent heat $\Delta H_s$ (J/g)
mPCM	25.36	27.55	97.85	25.94	25.19	96.33
RPU_5PCM	22.31	23.54	6.16	22.87	22.30	5.96

To characterize the energy storage properties of the pristine microencapsulated PCM (mPCM) and RPU\_5PCM foam specimens (melting and solidification temperature and enthalpy), a dynamic calorimeter (DSC 4000, PerkinElmer) was used, at a heating and cooling rate of 1°C/min, in the range of 10°C to 50°C under a nitrogen atmosphere. Table 1 summarizes the results of specific heat capacity versus temperature for the mPCM and RPU\_5PCM foam specimens and the latent heat,  $\Delta H$  (J/g) values for melting and solidification curves.

### Results

The results show that the enhancement in thermal conductivity of the RPU foams with and without mPCM increased with temperature. Using the HB-HFM approach and GHP approach, the value of the thermal conductivity of the RPU foam with mPCM comparatively to the RPU foam without mPCM is lower in respect to the TPS approach. However, the addition of the mPCM does not seem to have significant influence on the thermal conductivity of the RPU foams, because the variance on the thermal conductivity (in relation of the RPU foam without mPCM) obtained for the mPCM solid state was approximately -1.78% for the HB-HFM approach, -0.85% for the GHP approach and 4.97% for the TPS approach.

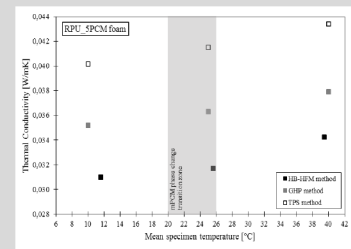
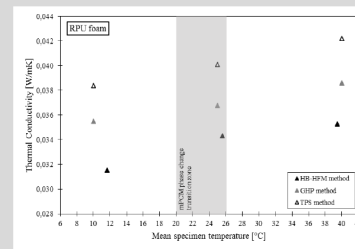

Comparison of thermal conductivity at 10°C, 25°C and 40°C for all approaches

### Conclusions

The thermal conductivity of the RPU foam with mPCM was simultaneously influenced by the temperature increase as well as by the phase change fraction of the mPCM. This behaviour was clearly observed using the HB-HFM and TPS approach, because in these two approaches the experiments involved measuring the thermal conductivity of the specimens at different temperatures in the range 2-40°C (range temperature that represent all the mPCM phases).

The TPS approach has some constrains for the thermal conductivity measurements with specimens incorporating mPCMs. The measurement is a combination of energy being transferred through the material and the energy stored or released in the phase change. The thermal conductivity is slightly affected and can be estimated by interpolating from a point before to a point after the phase change;

Promising results have been achieved but there is still a long path to go in terms of thermal conductivity measurements of the RPU foams with mPCMs, particularly during mPCM phase transition stage using steady-state and transient methods. It is important to identify the coupling effect of the temperature rise and the phase change fraction of the mPCM on the thermal conductivity value.

14-15 June, 2018

Department of Chemical Engineering  
University of Coimbra



Cofinanciado por:





U C

# Seminar - PCMs4Buildings

## PCMs: Thermophysical characterization and buildings' applications

# INCORPORATION OF PHASE CHANGE MATERIALS (PCM) IN CERAMICS FOR BUILDING APPLICATIONS

## Hélio Jorge<sup>1\*</sup>, Rui Novais<sup>2</sup>, Sónia Bastos<sup>3</sup>, Paula Seabra<sup>2</sup> and João Labrincha<sup>2</sup>

<sup>1</sup> Centro Tecnológico da Cerâmica e do Vidro (CTCV), Coimbra, Portugal

<sup>2</sup> Materials and Ceramic Engineering Department, CICECO, University of Aveiro, Aveiro, Portugal

<sup>3</sup> CINCA - Companhia Industrial de Cerâmica, SA, Fiães, Portugal

\* Correspondent author: Hélio Jorge, hrjorge@ctcv.pt



This article presents part of the work of developing methods for the incorporation of PCMs in ceramic materials for application in the construction. The tests performed show the variability in the incorporation ratio of the PCM incorporation process in materials with different pore sizes and porosities, indications of conditions where there is higher incorporation and some critical differences between the two methods. Thermal testing of ceramic tiles in porcelain and earthenware has demonstrated the influence of the thermal storage of PCM when incorporated in tiles, as also to preview the energy savings in buildings.

### PCM incorporation methods

	Infiltration of melted pure PCM	Infiltration of PCM microcapsules
<b>PCM type</b>	Pure PCM non-encapsulated	Suspensão aquosa de PCM microncapsulado
<b>Incorporation process</b>	Diffusion of melted PCM by capillary forces	Infiltration of suspension of microcapsules under pressure

### Infiltration of melted pure PCM: Filling ratio of pure PCM in porous tiles produced with different porous former Thermal storage: 12 a 280 kJ/m<sup>2</sup>

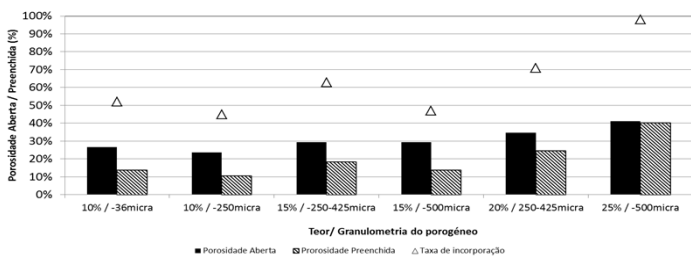

### Double layer dense-porous porcelain earthenware



### Infiltration of PCM microcapsules: Thermal storage: 33 a 90 kJ/m<sup>2</sup>

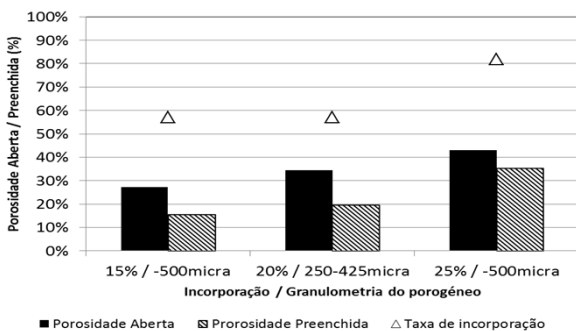

### PCM effect demonstration: Heating ratio delayed with higher PCM thermal storage

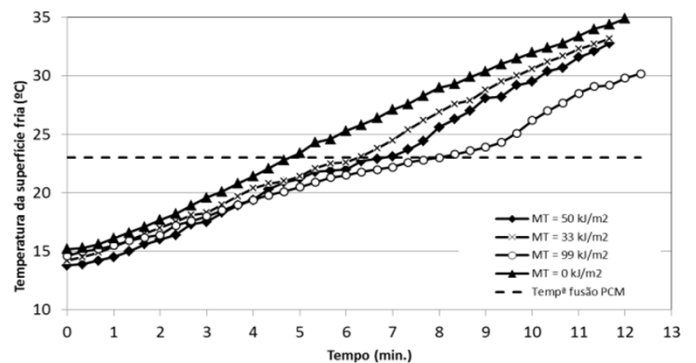

14-15 June, 2018  
Department of Chemical  
University of Coimbra



Cofinanciado por:





# Seminar - PCMs4Buildings

## PCMs: Thermophysical characterization and buildings' applications

# Thermal regulation of photovoltaic modules using thermal energy storage units with PCMs

N. Soares<sup>1,2,\*</sup>, A.R. Gaspar<sup>1</sup>, F. Nunes<sup>1</sup>, V. Lourenço<sup>1</sup>, J.J. Costa<sup>1</sup>

<sup>1</sup> ADAI, LAETA, Department of Mechanical Engineering, University of Coimbra, Coimbra, Portugal  
<sup>2</sup> ISE, Department of Civil Engineering, University of Coimbra, Coimbra, Portugal

\*Correspondent author: Nelson Soares, nelson.soares@dem.uc.pt

## Framework

High operating temperatures reduce the performance of commercial polycrystalline silicon photovoltaic (PV) devices by reducing the efficiency of solar to electrical energy conversion in the PV cells.

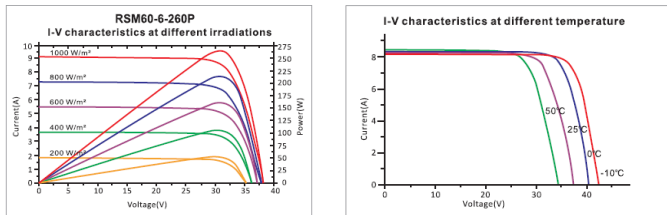
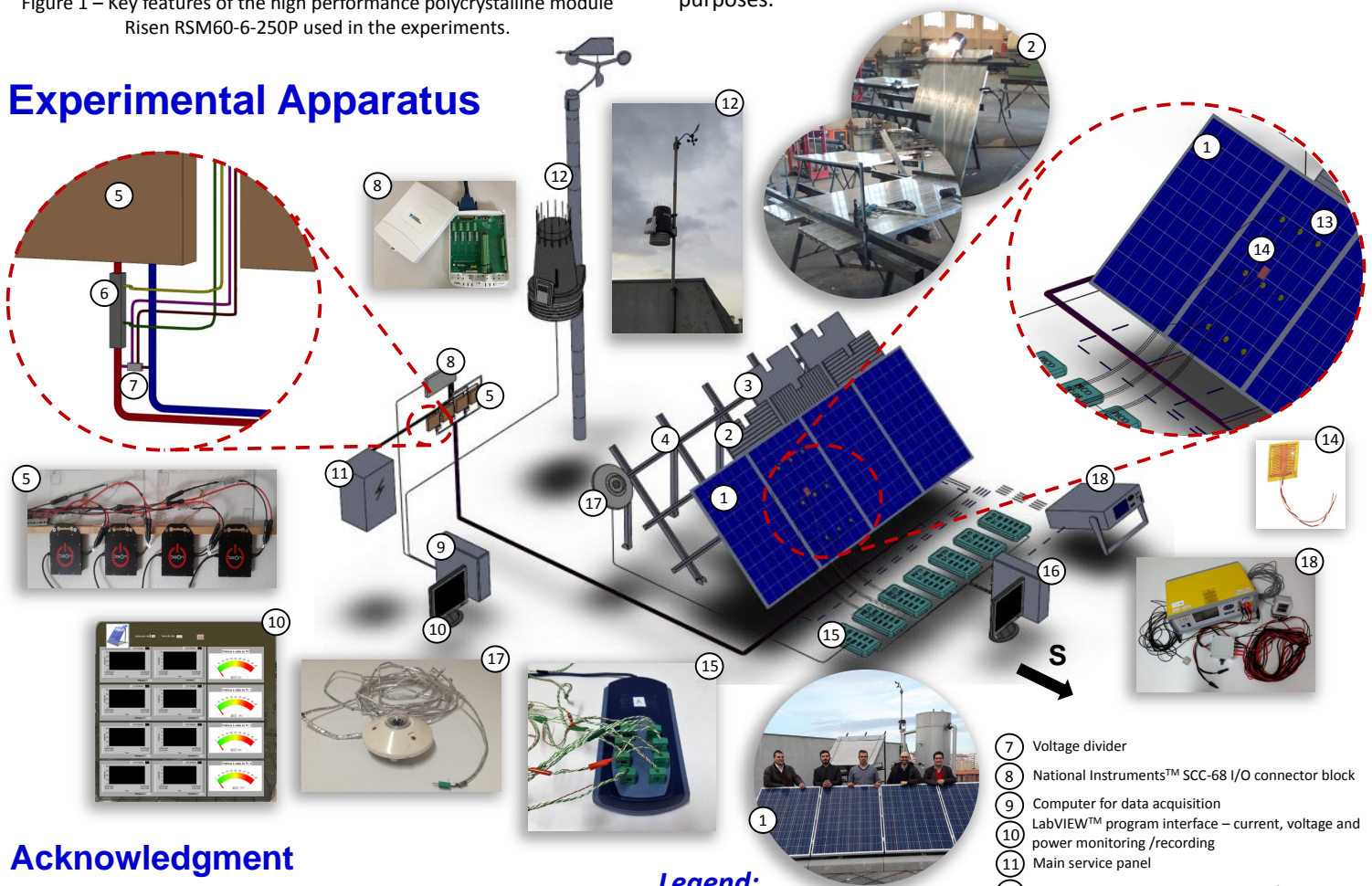

Figure 1 – Key features of the high performance polycrystalline module Risen RSM60-6-250P used in the experiments.

## Major Goals

- To develop a real-scale experimental apparatus to evaluate the performance improvement of PV/PCM systems incorporating thermal energy storage (TES) units filled with free-form PCMs. The TES units are intended to control the temperature rise in the PV cells;
- To carry out an experimental parametric study to evaluate the influence of different configurations of the TES unit (horizontally and vertically oriented cavities) and the impact of different phase-change temperature ranges of the PCM – the PCMs RT22HC, RT25HC and RT28HC from RUBITHERM® will be used;
- To provide reliable experimental results for numerical validation purposes.

## Experimental Apparatus



### Legend:

- ① Risen RSM60-6-250P PV modules
- ② Mobile TES units filled with PCMs
- ③ Mobile heat dissipation module
- ④ Support system
- ⑤ DC/AC microinverter BeOn
- ⑥ Shunt resistor
- ⑦ Voltage divider
- ⑧ National Instruments™ SCC-68 I/O connector block
- ⑨ Computer for data acquisition LabVIEW™ program interface – current, voltage and power monitoring /recording
- ⑩ Main service panel
- ⑪ Davis Instruments Vantage Pro2™ weather station
- ⑫ Thermocouples (K-type)
- ⑬ OMEGA™ flexible heat flux sensor HFS-4
- ⑭ Pico® USB TC-08 thermocouple data logger
- ⑮ PicoLog® data acquisition program
- ⑯ Kipp&Zonen CM11 pyranometer
- ⑰ PVPMT2540C mobile peak power and I-V-curve measurement device for PV modules

## Acknowledgment

This project is supported by FEDER funds through the COMPETE 2020 - POCl, and by Portuguese funds through FCT in the framework of the project POCI-01-0145-FEDER-016750 | PTDC/EMS-ENE/6079/2014. The authors thank João Carrilho for his help in the development of the data acquisition system. The authors also acknowledge the support of the company SunEnergy and the assistance of CTCV with their equipments.

[www.adai.pt/pcms4buildings](http://www.adai.pt/pcms4buildings)

14-15 June, 2018

Department of Chemical Engineering  
University of Coimbra



Cofinanciado por:





# MULTI-FUNCTIONAL VENTILATED BIPV FAÇADE CONCEPT COUPLED WITH PCM

Jakub Curpek<sup>1\*</sup>, Jozef Hraska<sup>1</sup>, Miroslav Cekon<sup>2</sup>

## Seminar - PCMs4Buildings

PCMs: Thermophysical characterization and buildings' applications

<sup>1</sup> Department of Building Construction, Faculty of Civil Engineering, Slovak University of Technology in Bratislava, Radlinskeho 11, Bratislava 813 68, Slovakia

<sup>2</sup> Research Centre AdMaS, Faculty of Civil Engineering, Brno University of Technology, Purkynova 139, Brno 612 00, Czechia

\* Correspondent author: Jakub Curpek, jakub.curpek@stuba.sk



### Motivation and Goals

The presented contribution is focused on the use of thermo-physical properties of phase change material (PCM) in a building integrated photovoltaic (BiPV) ventilated façade system. Two key functionalities of PCM integration into the façade are introduced: i. as heat exchanger inside the decentralized façade ventilation unit; ii. as thermal storage layer behind the BiPV cladding. The main objective of this motivation is to identify the influence of PCM implementation into the façade ventilation system on the overall building energy performance.

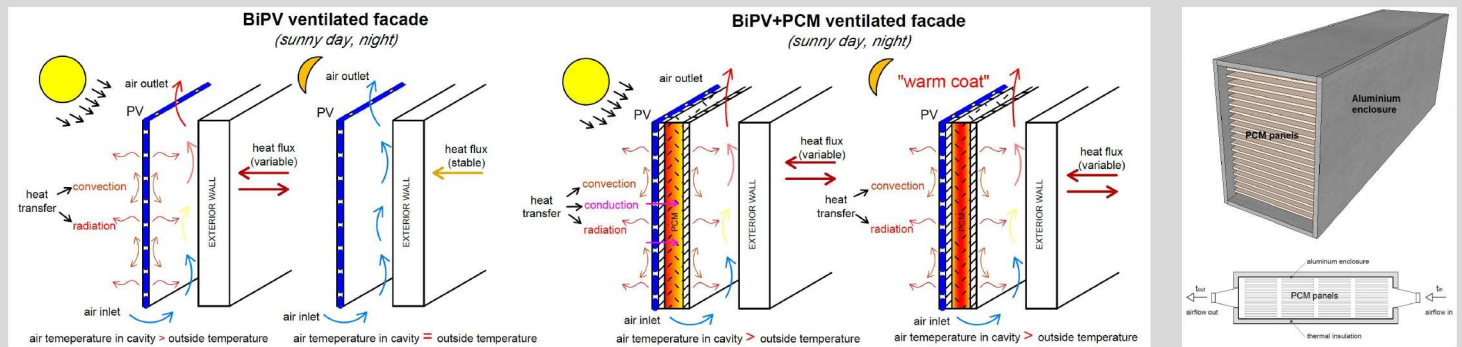

### Research challenges

Development and evaluation of different technical solutions and integration of progressive materials in building facades is highly relevant issue. Direct control of velocity and direction of the air from the façade cavity according to interior requirements can reveal an interesting potential of FIV system for it to provide a certain degree of air change rate. In addition, PCMs as responsive materials that can self-adjust its internal physical properties have an ability to store passive solar and other thermal energy as latent heat within a specific temperature range. Performance prediction and simulation of PCM-enhanced façade systems are currently being relevant research challenges.

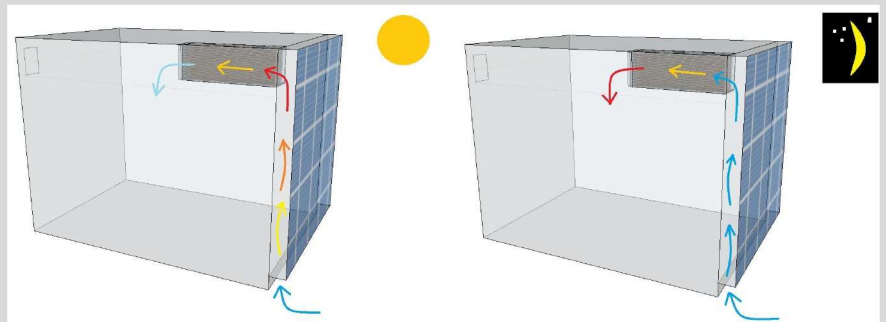

### Methodological approach

The key research methods are based on the experimental and building energy simulation (BES) studies. A specific experimental test platform was developed to provide experimental measurements on ongoing long-term full-scale level in Brno, Czechia. BES will be performed by using DesignBuilder software that works under EnergyPlus computational platform.

### Research results

Extensive measurements provide real performance data that will be used for the verification of BES model and for the optimization of the final design of BiPV/PCM façade concept.



### Acknowledgment

Authors gratefully acknowledge support provided by the Ministry of Education, Science, Research and Sport of the Slovak Republic under contract VEGA 1/0050/18 and by the project No. LO1408 "AdMaS UP – Advanced Materials, Structures and Technologies", supported by Ministry of Education, Youth and Sports of the Czech Republic under the "National Sustainability Programme I".

14-15 June, 2018

Department of Chemical Engineering  
University of Coimbra



Cofinanciado por:





# Properties of cement mortars with phase change materials (PCMs)

## Seminar - PCMs4Buildings

PCMs: Thermophysical characterization and buildings' applications

José B. Aguiar<sup>1\*</sup>, Sandra Cunha<sup>1</sup>

<sup>1</sup> Centre for Territory, Environment and Construction, Department of Civil Engineering, University of Minho, Campus de Azurém, 4800-058 Guimarães, Portugal

\* Correspondent author: José B. Aguiar, [aguiar@civil.uminho.pt](mailto:aguiar@civil.uminho.pt)

Combining the use of solar energy and functional construction materials is possible to obtain a more sustainable construction.



The main objective of this study was the evaluation of several properties of mortars with incorporation of microencapsulated and non-encapsulated PCM.

**PCM Microcapsules** - Composed of a wall in melamine-formaldehyde and a core in paraffin, with temperature transition of about 22.5 °C and enthalpy of 147.9 kJ/kg.

**PCM Non-encapsulated** - Composed by paraffin with temperature transition between 20 and 23°C and enthalpy of 200 kJ/kg.

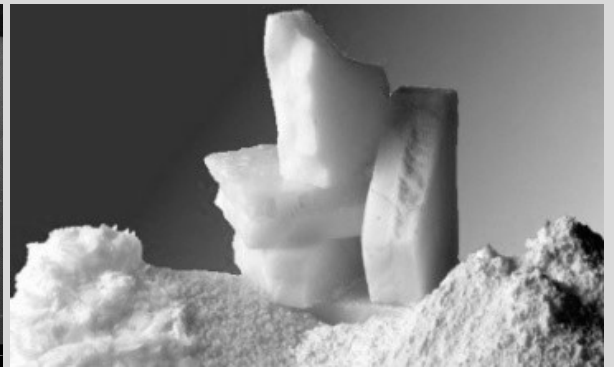
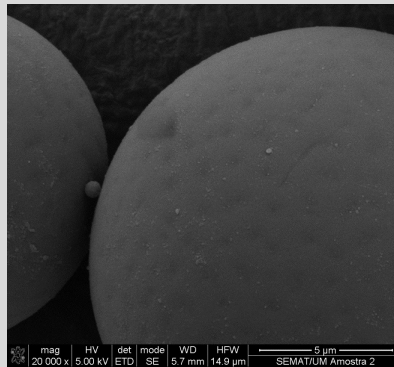
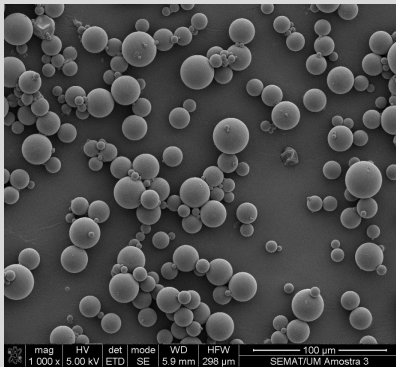

The incorporation of microencapsulated and non-encapsulated PCM cause some changes in the cement mortars properties. However, the utilization of PCM mortars for interior coating can reduce the energetic consumptions, reducing the energy demand, the fossil fuel depletion and the environmental impact associated with the heating and cooling systems.

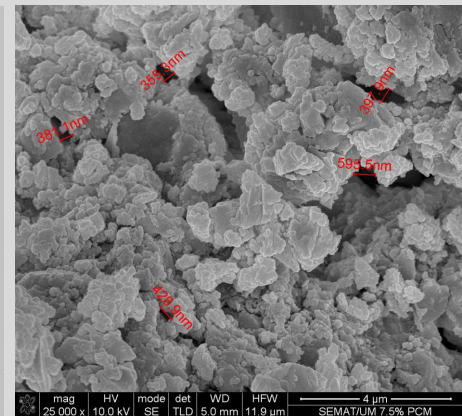
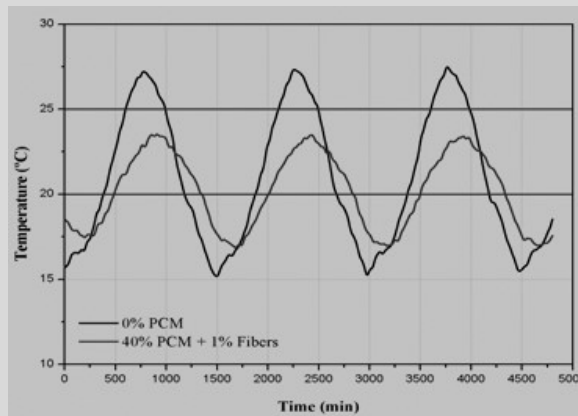
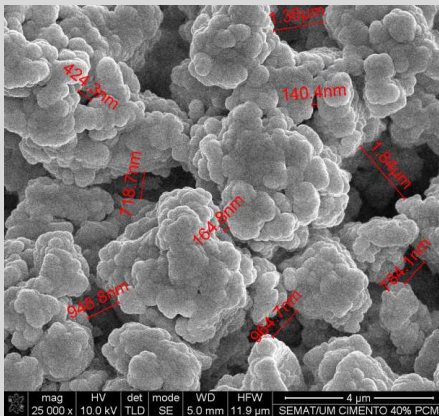

Mortar with PCM Microcapsules

Thermal Behaviour – Spring Season

Mortar with Non-encapsulated PCM



# Phase Change Materials for Improving the Thermal Performance of LSF Construction

Paulo Santos<sup>1\*</sup>, Margarida G. Gonçalves<sup>1</sup>, Cláudio Martins<sup>1</sup>, Nelson Soares<sup>1,2</sup>, José J. Costa<sup>2</sup>

## Seminar - PCMs4Buildings

### PCMs: Thermophysical characterization and buildings' applications

<sup>1</sup> ISISE, Department of Civil Engineering, University of Coimbra, Pólo II, Rua Luís Reis Santos, 3030-788 Coimbra, Portugal

<sup>2</sup> ADAI, LAETA, Department of Mechanical Engineering, University of Coimbra, Pólo II, Rua Luís Reis Santos, 3030-788 Coimbra, Portugal

\* Correspondent author: Paulo Santos, pfsantos@dec.uc.pt

## 1. Motivation and Objectives

- The research project "PCMs4Buildings" (Systems with PCM-filled rectangular cavities for the storage of solar thermal energy for buildings) is funded by FCT and by FEDER/COMPETE2020/POCI.
- The main goal of this project is the development of systems with PCM-filled rectangular cavities for the storage of solar thermal energy in order to enhance the energy performance of buildings.
- Given their reduced thermal mass, lightweight steel framed (LSF) buildings are very suitable for the use of phase change materials (PCMs).
- Therefore, the PCMs4Buildings project mainly focusses on LSF construction, namely in Task 4 – "Tests in the Guarded Hot Box Apparatus" and in Task 5 – "Definition of full-scale prototypes".
- The main objective of this communication is to describe the research activities related with Task 4 and the obtained results, as well as the future work.

## 2. PCMs4Buildings Research Project

The research plan is composed by six tasks:

- Thermophysical characterization of PCMs;
- Numerical modelling and CFD evaluation;
- Tests in the small-scale experimental setup;
- Tests in the Guarded Hot Box apparatus;
- Definition of full-scale prototypes;
- Technical seminar and workshop.

Systems with PCM-filled rectangular cavities for the storage of solar thermal energy for buildings

www.adai.pt/pcms4buildings

COMPETE 2020 | PORTUGAL 2020 | FCT

POCI-01-0145-FEDER-016750 | PTDC/EMS-ENE/6079/2014

## 3. (Guarded) Hot Box Apparatus

This equipment was designed and assembled at ISISE-DEC/FCTUC and will allow to measure the thermal transmittance  $U$ -value of heterogeneous walls at real-scale test-specimens.

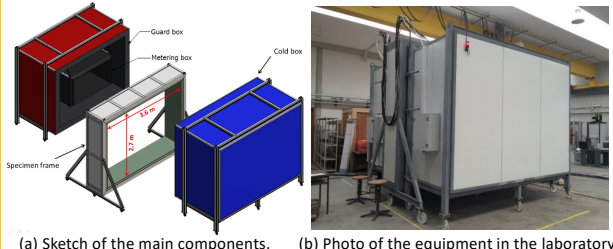

## 4. Experimental Tests

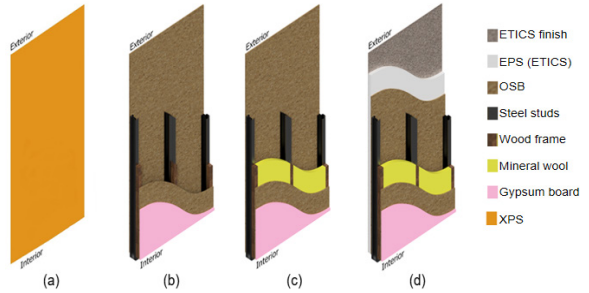

Tested walls: (a) homogeneous XPS panel; and heterogeneous LSF walls: (b) without thermal insulation; (c) with mineral wool (MW) in air-cavity; (d) with MW in air-cavity and ETICS.

Table 1.  $U$ -values obtained for the LSF walls based on experimental data.

Wall typology	Thermal transmittance, $U$ [ $W/(m^2 \cdot ^\circ C)$ ]			
	Between steel studs 0	Near steel studs 1	Near steel studs 2	Overall weighted value
1-Without thermal insulation	1.568	1.041	1.203	1.480
2-With Mineral Wool (MW) in air-cavity	0.658	0.788	1.128	0.711
3-With MW in air-cavity and ETICS	0.279	0.363	0.470	0.324

## 5. Numerical Simulations

Used tools: **Therm** for the 2D approach & **ANSYS** for the 3D approach.

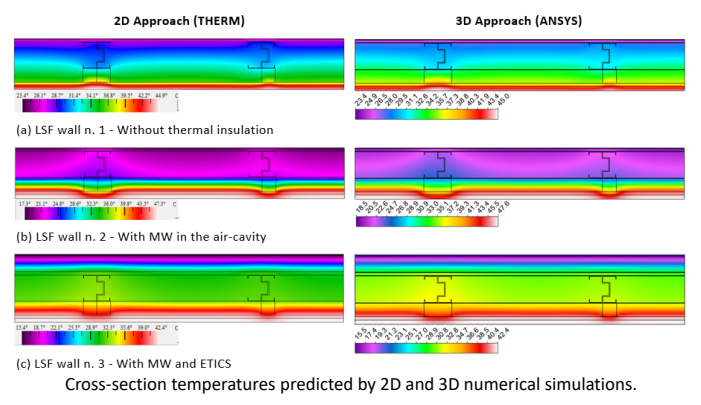
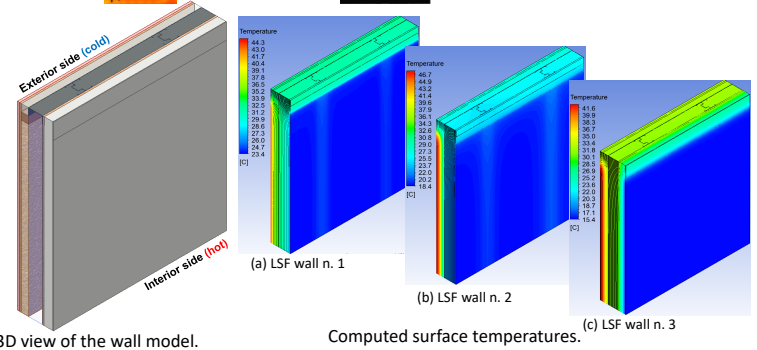

## 6. Experimental vs Numerical Results

Table 2. Experimental and numerical  $U$ -values obtained for the LSF walls.

	Wall n.1 - Without Thermal Insulation			Wall n.2 - With Mineral Wool (MW)			Wall n.3 - With MW and ETICS		
	Exp.	ANSYS	THERM	Exp.	ANSYS	THERM	Exp.	ANSYS	THERM
$U$ -value [ $W/m^2 \cdot ^\circ C$ ]	1.480	1.409	1.399	0.711	0.598	0.581	0.324	0.346	0.306
Absol. Diff.	---	-0.071	-0.081	---	-0.113	-0.130	---	+0.022	-0.018
Perc. Diff.	---	-4.8%	-5.5%	---	-15.9%	-18.3%	---	+6.8%	-5.6%

## 7. Future Work

- To include PCMs in the simpler LSF wall (already tested) and to perform tests not only in steady-state but also in transient regime.
- To test different LSF wall typologies with more complex steel frame (also horizontal and diagonal steel studs), with and without integrated PCMs.
- To compare the measured results with the numerical simulation results, including CFD (Computational Fluid Dynamics).

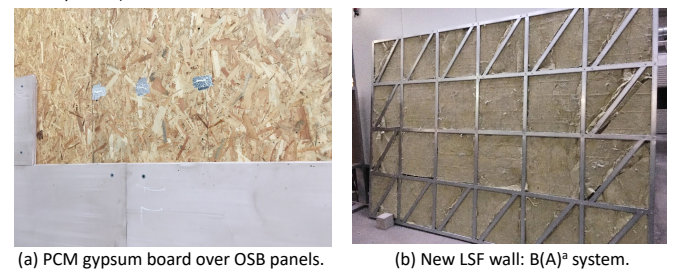

This project is supported by FEDER funds through the COMPETE 2020 - Operational Programme for Competitiveness and Internationalization (POCI), and by Portuguese funds through FCT in the framework of the project POCI-01-0145-FEDER-016750 | PTDC/EMS-ENE/6079/2014.

14-15 June, 2018

Department of Chemical Engineering  
University of Coimbra





# Thermal performance of a window shutter with phase change materials

Tiago Silva<sup>1,\*</sup>, Romeu Vicente<sup>2</sup>, Maria Fernanda Rodrigues<sup>2</sup> and Cláudia Amaral<sup>1,2</sup>

## Seminar - PCMs4Buildings

### PCMs: Thermophysical characterization and buildings' applications

<sup>1</sup> CICECO, Aveiro Institute of Materials, Civil Engineering Department, University of Aveiro, Campus Universitário de Santiago, 3810-193 Aveiro, Portugal

<sup>2</sup> RISCO, Civil Engineering Department, University of Aveiro, Campus Universitário de Santiago, 3810-193 Aveiro, Portugal

\* Tiago Silva, Tel.: +351 234 370 845, Fax: +351 234 370 094, email: tiagomsilva@ua.pt

### Motivation and Goals

The use of phase change materials (PCMs) is a promising solution to improve the energy performance of building elements considering their capacity to store and release energy. This capacity contributes to minimize the maximum and minimum indoor air temperature peaks and to reduce the buildings energy demand.

The main goal of this work is to research and to evaluate the thermal performance of a window shutter with PCMs.

The main objectives could be summarized by:

- Development and present a thermal energy storage system;
- Present the testing apparatus and the results over the thermal behaviour and energy demand;
- Results comparison of the reference window shutter versus the PCM window shutter.

### Work plan / Methodology

The testing cell was submitted to real weather conditions and a instrumentation apparatus to collect data was defined. The main structure of the window shutter is aluminium and four similar window shutters were built. The blades of two of the window shutters were filled with PCM ("PCM compartment") and the others two were left empty ("Reference compartment"). The thermal-physical properties of the PCM are present below:

$T_f$	Melting/solidification range	[°C]	27 – 29
$L_f$	Latent heat storage capacity $\pm 7,5\%$	[kJ.kg <sup>-1</sup> ]	245
$C_p$	Specific heat capacity	[kJ.kg <sup>-1</sup> .K <sup>-1</sup> ]	2
$\rho_s$	Mass density solid phase	[kg.m <sup>-3</sup> ]	880
$\rho_l$	Mass density liquid phase	[kg.m <sup>-3</sup> ]	770
$\lambda$	Thermal conductivity	[W.m <sup>-1</sup> .K <sup>-1</sup> ]	0.2
$\Delta V$	Volume expansion	[%]	12.5

The window shutter is composed by insulation material (XPS), aluminium blades filled with PCM (or empty) and two the aluminium structures that supports all components.

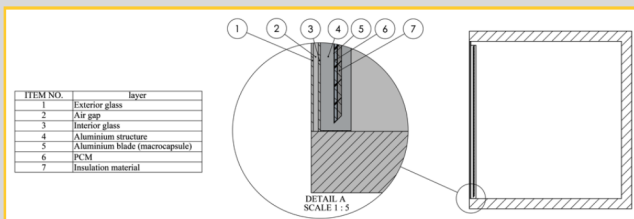

### Results

#### Summer week

The test cell was submitted to average solar radiation of 237 [W.m<sup>-2</sup>] to 306 [W.m<sup>-2</sup>]. The external air temperature ranges from 13°C to 25°C.

- During the charging and discharging process of the PCM, the window shutter with PCM can reduce the indoor compartment temperature about -22% to 18% (minimum and maximum value correspondently);
- The window shutter with PCM can decrease the maximum and minimum temperatures peaks about 6% and 11%. During this time, the use of PCM in the window shutter solution could increase 45min the time delay for the minimum temperature peak and 1h the time delay for the maximum temperature peak, compared to the reference compartment.

#### Winter week

- At the maximum indoor air temperature peak the temperature reduction of the compartment with the PCM shutter is about 30% to 40% over, but for the minimum indoor air temperature the improvement is practically null (both compartments have similar minimal temperatures);

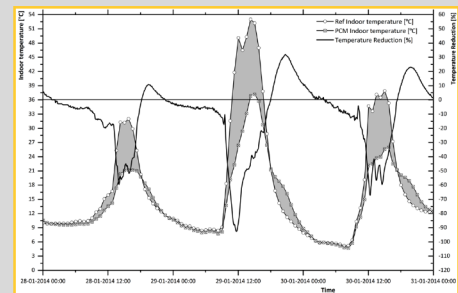

- The maximum indoor temperature of the compartment with the PCM shutter is 37.2°C, which is 16.6°C lower than the indoor air temperature of the reference compartment and is reached 1:15h later;
- Comparing the indoor temperatures over time, the temperature reduction can reach 90% (when the indoor air temperatures increases) and up to 35% (when the indoor air temperatures drops).

### Conclusions

The PCM provided an additional thermal inertia capacity that is recorded by the indoor air temperatures and heat flux results attained.

For both compartments, and selected weeks, the overheating inside of the test cell was higher than the expected. During the day the PCM melted completely and stayed in this condition too long that it allowed to increase the compartment internal air temperature above comfortable conditions.

14-15 June, 2018

Department of Chemical Engineering  
University of Coimbra



Cofinanciado por:







# A degradation model and the associated activation energy of organic phase change materials

Daniela Silva<sup>1</sup>, Tiago Vieira<sup>1</sup>, Nuno Rocha<sup>1\*</sup>, Marina Torres<sup>1</sup>, Carla Gomes<sup>1</sup>, Susana Sousa<sup>1</sup>, Joana Guedes<sup>1</sup>, Marcela Teixeira<sup>2</sup>, Nuno Correia<sup>1</sup>

## Seminar - PCMs4Buildings

### PCMs: Thermophysical characterization and buildings' applications

<sup>1</sup> INEGI – Institute of Science and Innovation in Mechanical and Industrial Engineering, Campus FEUP, Rua Dr. Roberto Frias, 400, 4200-465 Porto  
<sup>2</sup> CABELTE – Cabos elétricos e telefónicos, S.A., Rua de Espírito Santo, 4410-420 Vila Nova de Gaia

\* Correspondent author: Nuno Rocha, nrocha@inegi.up.pt

### Motivation

- Development of new high-voltage (HV) power cables with higher yield;
- Integration of heat management system;
- Reduce heat losses and increase durability under operation;
- Increase cable capability to transfer current.

### Goal

Application of Phase Change Materials (PCM) in the cable structure, able to absorb and release big quantities of heat at constant temperature, during the change in their physical state.

### PCM selection

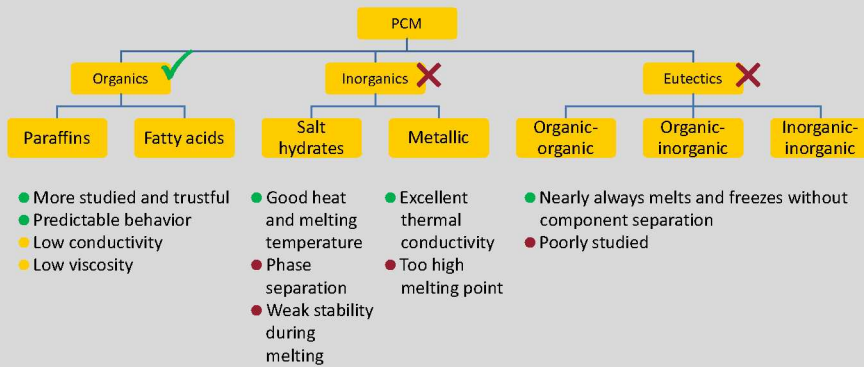

### Thermal model

A thermal model was created to design new high-efficiency HV cables:

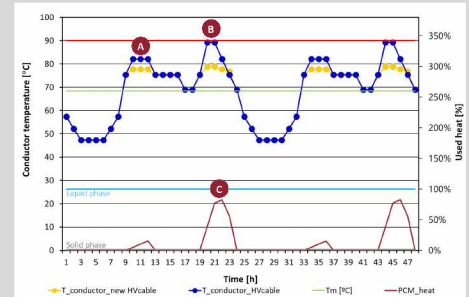

- 1 The load cycle under study represents the typical electrical use of a standard winter day.
- 2 Over the installation lifetime it is estimated that the new HV power cable will allow a thermic reduction on points of higher electrical use **A** and **B**.
- 3 This reduction is associated with the heat absorbed **C** by the PCM and also on the amount of material inserted in the cable.

Following this study, laboratory tests were performed that prove the occurrence of thermal reductions, which in turn could lead to electric current gains.

### Cable production and new structure

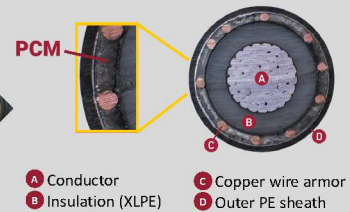

“Cabo eléctrico”, Patent number 110501A

### PCM: Durability, efficiency loss and lifetime

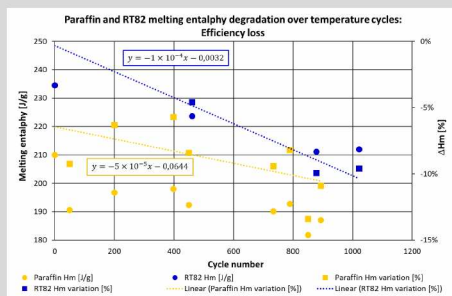

Melting enthalpy reduction of 10% for 1000 thermal cycles (1 thermal cycle = 1 day)

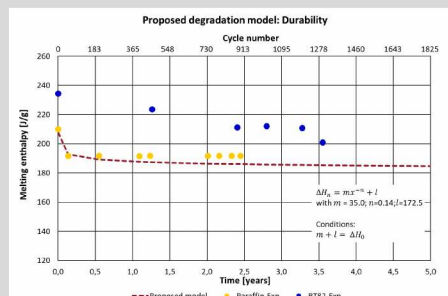

Stabilization of melting enthalpy decay after 2 years of use

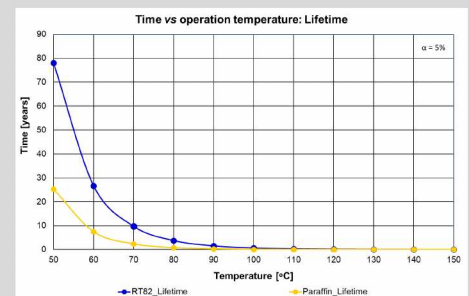

Kinetics models showed a lifespan of 25 years for paraffin and 80 years for RT82, with an operation temperature of 50 °C

### Acknowledgements

The authors wish to acknowledge NORTE-01-0145-FEDER-000022-SciTech-Science and Technology for Competitive and Sustainable Industries, co-financed by NORTE2020, through ERDF and also project CATER – Project Number 009974 cofounded by the Norte regional operational program (P2020) through ERDF.

14-15 June, 2018

Department of Chemical Engineering  
University of Coimbra





# BEESWAX AS PHASE CHANGE MATERIAL: CHEMICAL MODIFICATION AND MIXTURES WITH HYDROGENATED WASTE COOKING OIL AND WITH PARAFFIN.

João A. Baptista<sup>1\*</sup>, M. Ermelinda S. Eusébio<sup>1</sup>, Mariette M. Pereira<sup>1</sup>

## Seminar - PCMs4Buildings

PCMs: Thermophysical characterization and buildings' applications

<sup>1</sup> Centro de Química, Departamento de Química, Faculdade de Ciências e Tecnologia, Universidade de Coimbra, Rua Larga 3004-516

\* Correspondent author: João A. Baptista, email: j.agria.baptista@gmail.com

## Motivation and Goals

Beeswax is a natural product made of several compounds, mainly alkanes, alkenes, free fatty acids and esters, diesters and hydroxiesters. In this work, beeswax from a Portuguese production in Alentejo was characterized by GC-MS<sup>[1]</sup> and the thermal behavior was evaluated for its potential use as a PCM. Transesterification of beeswax esters to methyl esters was carried out in order to modify the beeswax thermal properties. Moreover, mixtures of beeswax with hydrogenated waste cooking oil and with paraffin were also evaluated as potential PCMs<sup>[2]</sup>.

## Results

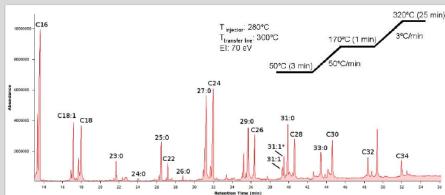

Figure 1: Chromatogram GC/MS obtained from the injection of 1  $\mu$ l of a chloroform solution of transesterified beeswax.

Table 1: Methyl esters and saturated hydrocarbons found in higher quantity in the transesterified beeswax, identified by their mass spectrum.

Methyl Ester	R T (min)	Hydrocarbon	R T (min)
C16	13.59	23:0	25.83
C18	17.64	25:0	26.49
C22	27.17	26:0	28.80
C24	31.99	27:0	31.22
C26	36.42	29:0	35.72
C28	40.67	31:0	39.97
C30	44.70	33:0	43.48
C32	48.48		
C34	52.06		

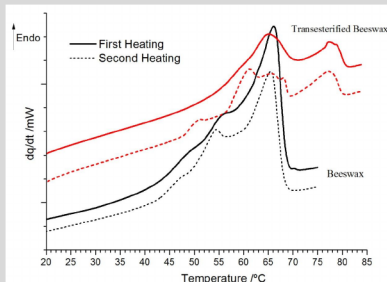

Figure 3: DSC thermograms obtained in the first and second heating runs carried out on beeswax and transesterified beeswax samples, scanning rate  $|\beta| = 5^\circ\text{C}\cdot\text{min}^{-1}$

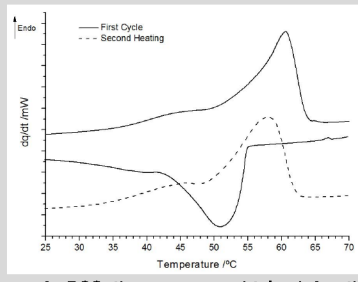

Figure 4: DSC thermograms obtained for the first heating cycle and second heating of the paraffin/beeswax mixture 3:2 (m:m), scanning rate  $|\beta| = 5^\circ\text{C}\cdot\text{min}^{-1}$

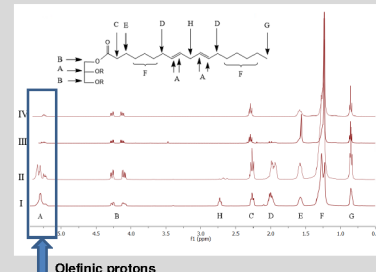

Figure 2: <sup>1</sup>H-NMR obtained from the virgin oil (I); after C/Pd catalytic hydrogenation ( $\text{H}_2 = 4$  bar) (II), hydrogenated sample ( $\text{H}_2 = 10$  bar) (III) and hydrogenated waste cooking oil ( $\text{H}_2 = 10$  bar) (IV).

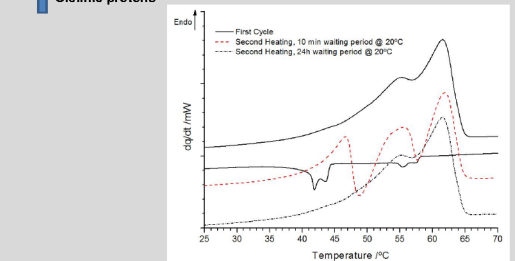

Figure 5: DSC thermograms obtained for the first heating cycle and second heating (after 10min and 24h at ambient temperature) of the hydrogenated oil/beeswax mixture 1:1 (m:m), heating rate  $\beta = 5^\circ\text{C}\cdot\text{min}^{-1}$  and intermediary cooling rate  $|\beta| = 2^\circ\text{C}\cdot\text{min}^{-1}$

Table 2: Thermal behavior data obtained in consecutive heating runs and intermediary cooling, performed by DSC on beeswax, transesterified beeswax and a mixture of beeswax with 60% paraffin (m:m).

	First Heating				Second Heating				Cooling			
	$T_i/^\circ\text{C}$	$T_f/^\circ\text{C}$	$T_p/^\circ\text{C}$	$\Delta H/\text{kJ}\cdot\text{kg}^{-1}$	$T_i/^\circ\text{C}$	$T_f/^\circ\text{C}$	$T_p/^\circ\text{C}$	$\Delta H/\text{kJ}\cdot\text{kg}^{-1}$	$T_i/^\circ\text{C}$	$T_f/^\circ\text{C}$	$T_p/^\circ\text{C}$	$\Delta H/\text{kJ}\cdot\text{kg}^{-1}$
Beeswax (n=5)	31.3 $\pm$ 0.4	70.5 $\pm$ 1.4	65.2 $\pm$ 0.6	170 $\pm$ 3.4	31.8 $\pm$ 1.2	69.3 $\pm$ 1.3	64.9 $\pm$ 0.5	160 $\pm$ 4.8	60.3 $\pm$ 0.4	34.8 $\pm$ 1.4	59.4 $\pm$ 0.2	-146 $\pm$ 5
Transesterified Beeswax (n=4)	43.1 $\pm$ 2.6	78.4 $\pm$ 0.7	60.3 $\pm$ 1.7	206 $\pm$ 23	42.5 $\pm$ 4.4	78.1 $\pm$ 0.4	58.8 $\pm$ 0.2	203 $\pm$ 17	72.5 $\pm$ 0.8	36.8 $\pm$ 2.9	56.0 $\pm$ 1.4	-205 $\pm$ 17
P3:2 (n=4)	29.6 $\pm$ 0.8	64.5 $\pm$ 1.6	59.6 $\pm$ 1.2	180 $\pm$ 4	28.5 $\pm$ 0.3	63.8 $\pm$ 1.2	58.3 $\pm$ 1.0	182 $\pm$ 3	55.7 $\pm$ 0.7	28.1 $\pm$ 0.8	55.5 $\pm$ 1.2	-165 $\pm$ 6

$T_i$ - Initial Temperature,  $T_f$ - End Temperature,  $T_p$ - Peak Temperature,  $\Delta H$ - Enthalpy.

Table 3: Thermal properties of the 1:1 (m:m) hydrogenated oil/beeswax mixture, n=3.

First Heating				Cooling			
$T_i/^\circ\text{C}$	$T_f/^\circ\text{C}$	$T_p/^\circ\text{C}$	$\Delta H/\text{kJ}\cdot\text{kg}^{-1}$	$T_i/^\circ\text{C}$	$T_f/^\circ\text{C}$	$T_p/^\circ\text{C}$	$\Delta H/\text{kJ}\cdot\text{kg}^{-1}$
34.1 $\pm$ 0.4	67.3 $\pm$ 1.3	63.1 $\pm$ 1.7	169 $\pm$ 4	60.1 $\pm$ 1.2	29.0 $\pm$ 6.7	43.6 $\pm$ 0.6	-112 $\pm$ 2

$T_i$ - Initial Temperature,  $T_f$ - End Temperature,  $T_p$ - Peak Temperature,  $\Delta H$ - Enthalpy.

Table 4: Variation in volume during the phase transition determined for paraffin and for the mixture with 40% beeswax (m:m).

	V solid /ml	V liquid /ml	Variation (%)
Paraffin (n=3)	4.9 $\pm$ 0.1	5.3 $\pm$ 0.1	9.3 $\pm$ 1.6
P3:2 (n=3)	4.6 $\pm$ 0.2	4.8 $\pm$ 0.2	4.4 $\pm$ 0.2

## Conclusions

- Beeswax is a natural non-toxic product (food grade) that has great potential for application as PCM material.
- Transesterified beeswax have improved considerably its properties for use as PCM ( increase of melting enthalpy 12%; increase of phase change temperature range by 15°C); there are no significant differences in the undercooling (Figure 3, Table 2).
- Mixture of Beeswax(40%) with paraffin also improved its properties for use as PCM ( increase of melting enthalpy 12%; decrease of peak temperature by 4°C); there are no significant differences in the undercooling (Figure 4, Table 2).
- Preliminary tests carried out on paraffin/beeswax mixtures also showed a significant reduction in the variation of volume during the phase transition when compared to pure paraffin (Table 4).
- Mixtures of beeswax with hydrogenated vegetable oil would be a ideal mixture. These preliminary studies showed an increase of 4% in the melting enthalpy and a decrease of 4°C in the peak temperature (Figure 5, Table 3). However, due to the characteristic polymorphic behavior of triacylglycerides<sup>[4]</sup>, mixtures with hydrogenated oil must be used with caution. Thermal cycles should have a 24h period between heating runs to allow the hydrogenated oil to crystallize in its most stable form. Currently, we are investigating nucleating agents in an attempt to modify this polymorphic behavior.

### REFERENCES

- [1]- J.J. Jiménez, J.L. Bernal, S. Aumente, and et al., "Quality assurance of commercial beeswax II. Gas chromatography–electron impact ionization mass spectrometry of alcohols and acids," *Journal of Chromatography A*, vol. 1007, pp. 101–116, 2003.
- [2]- A. Sharma, V.V. Tyagi, C.R. Chen, and D. Buddhi, "Review on thermal energy storage with phase change materials and applications," *Renewable and Sustainable Energy Reviews*, vol. 13, pp. 318–345, 2009.
- [3]- M.M. Dell'Anna, M. Gagliardi, P. Mastrorilli, and et al., "Hydrogenation reactions catalyzed by a supported palladium complex," *Journal of Molecular Catalysis A: Chemical*, vol.158, pp. 515-520, 2000.
- [4]- L. Hermqvist, "Polymorphism of Triglycerides a Crystallographic Review," *Food Structure*, vol. 9, pp. 39-44, 1990.

14-15 June, 2018

Department of Chemical Engineering  
University of Coimbra



Cofinanciado por:



